

Application of Concurrent Design Strategy in Toaster Design

Bing-Hou Lin (Department of Industrial Design, National Cheng Kung University, Taiwan)

Shih-Wen Hsiao (Department of Industrial Design, National Cheng Kung University, Taiwan)

E-mail: swhsiao@mail.ncku.edu.tw

Abstract—This article uses a concurrent design method for the design of the toaster. Search for existing products, safety regulations for analysis, and then determine the functional items of the toaster through Objectives tree and Functional Analysis, and design specifications. The form of the toaster is thought to be created by Morphological Analysis. After selecting the elements of the Objectives tree and using Analytical Hierarchy Process to calculate the evaluation weight, Pugh selects the better design. Finally, the color scheme is used to perform the final color matching step, and the aesthetic degree is calculated to evaluate the color scheme. We apply CAD technology to integrate the concurrent design process to shorten development time and achieve complete commoditization results.

Keywords—concurrent design strategy, toaster, Objectives tree, Morphological Analysis, Analytical Hierarchy Process, Pugh, Color Aesthetic

I. INTRODUCTION

The purpose of the user is to quickly get toast, and the internal cleaning is often neglected by the user due to complexity. Directly replace old machines and purchase new machines, causing unnecessary waste in environmental protection and money. In terms of cleanliness : (a)There are electrical and hot parts inside the toaster, so users will be afraid of machine damage caused by cleaning. (b)The interior of the toaster is complex, and cleaning the interior is too expensive for the consumer. Dirty inside the machine will have a negative impact on the environment and health.

II. THEORETICAL BACKGROUND

A. Objectives tree

Objectives tree setting is an extremely important step in product development. The aim of the objectives tree method is to clarify design objectives and sub-objectives, and the relationships between them[1]. The process of drawing the target tree not only helps people to clarify the design goals but also helps the client managers and design teams to unify the goals. Knowing the design goals of the product, we can design products that truly meet the needs of the market.

B. Function Analysis Method

The aim of function analysis is to establish the functions required, and the system boundary, of a new design[1]. In the design process, the input and output are used to define the function of the whole product and give a limit to the product function. Then the whole function is subdivided into multiple sub-functions, and the interaction of all sub-functions is carried out in the black box. Then search for the appropriate elements to perform these sub-functions and the interactions between them, and you can find many alternatives to perform these explicit functions.

C. Morphological Analysis

The basic procedure of Morphological Analysis is reorganizing or combining all of the possible solutions to achieve a variety of design proposals. This method can generate a lot of design options and feasible solutions. Based on the content of a problem, Morphological Analysis produces a matrix that can solve the problem; it includes existing or traditional problem-solving methods[3].

D. Analytical Hierarchy Process

The analytic hierarchy process was developed by US scholar Thomas L. Saaty in 1971. It is applied to fields with uncertainty and the strategic decision of problems with multiple assessment criteria [4]. The procedure is to de-compose a complex system into a hierarchy to capture the basic elements of the problem and then calls for simple pairwise comparison judgments to develop priorities in each hierarchy[5]. The operating procedure consists of six steps which are respectively: (1) analyze the problem and spread assessment indices out; (2) construct the hierarchy framework; (3) establish the dual matrix; (4) seek a solution to eigenvalues and eigenvectors; (5) examine the consistency of the dual matrix; (6) solve for the priority weights of various indices[6]

E. Pugh concept selection

The basic method of this method is to score the design ideas according to the degree of consumer demand. After comparison, the highest score is selected as the best design. The operating procedure consists of four steps :

(1) Determine comparison items; (2) Select the alternatives to be compared (datum); (3) Score, $+(+1)$: better than datum, $-(-1)$: poor than datum, $S(0)$: equivalent or incomparable with datum; (4) Calculate the total score [2][7]

F. Color Aesthetic

Hiroshi Ohchi and Birkhoff's theory of aesthetics proposed by Moon and Spencer, a set of color aesthetic formulas constructed by order and complexity. Two elements to consider the aesthetics, Element in Order and Element in Complexity. M indicates aesthetics, O indicates Order, C indicates complexity. $M=O/C$ is Aesthetic evaluation [8][9].

III. CASE STUDY

To understand the difference in market products by discussing the related image of the existing commercial toaster with Image scale (Fig. 1). Complex, concise as the vertical axis of coordinates. Rounded, rigid as a coordinate horizontal axis. We can see that the current products on the market lack a rigid and concise product shape. Then compare the brand, material, size, and function of the eight products on the market (Fig. 2). It can be known that the main baking functions of the products are perfect, but it is difficult to disassemble and clean the interior baking space.

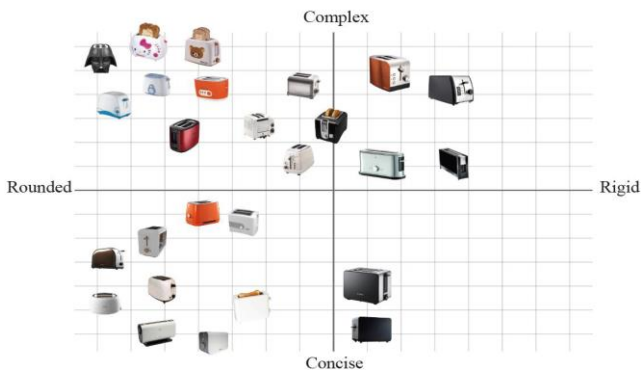

Fig. 1. Image scale

Brand	Sampo	Sunpustoven	Kolin	PHILIPS	Panasonic	itter	Kenwood	Breville
Body size	248x150x172mm	280x185x175mm	207-180-180mm	300x201x172mm	294x188x175mm	382x198x99mm	220x165x150mm	293x200x193mm
Body color	Purple	Silver	White	Silver + Black	White	Black	White	White
Material	Stainless steel	Stainless steel	plastic	stainless steel + plastic	plastic	tempered glass + plastic	Stainless steel	Stainless steel
Temperature stages	6	7	7	7	5		5	5
Clip tray	●	●	●	●	●	●	●	●
Cancel function	●	●	●	●	●	●	●	●
Release function	N/A	●	●	●	●	●	N/A	●
Thawing function	N/A	●	●	●	●	●	●	●
Warming collection	N/A	N/A	●	N/A	N/A	N/A	N/A	N/A
Dust cover	N/A	N/A	N/A	●	N/A	N/A	●	N/A
Anti-scalding shell	N/A	N/A	●	●	N/A	●	N/A	N/A
Bread baking rack	N/A	N/A	●	●	●	●	●	●
Baking trough	Thick type	Basic type	Thick type	Basic type	Basic type	Basic type	Basic type	Thick type
LED display	N/A	N/A	N/A	N/A	N/A	●	N/A	●
Weight	1.12KG	1.1KG	1.5KG	2.03KG	1.3KG	3.1KG	1.9KG	1.75KG
Power consumption	650W	850W	750W	950W	650W	770W	750W	820W

Fig. 2. Existing product

A. Function Analysis

From this functional analysis, the operation of the toaster can be clearly understood (Fig. 3). The generated

debris dust, waste heat, etc. are included in the design specifications.

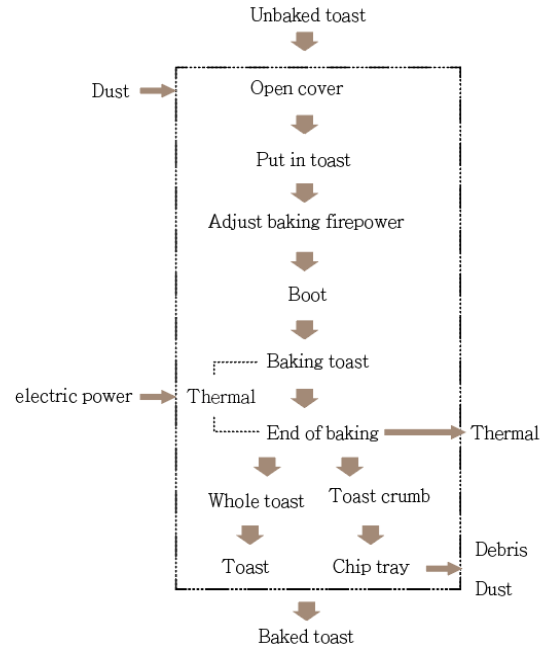

Fig. 3. Function analysis

B. Objectives tree

Based on previous analysis and survey data, the Objectives tree can be drawn and can be divided into four levels: safety, operation, clean, and function (Fig. 4).

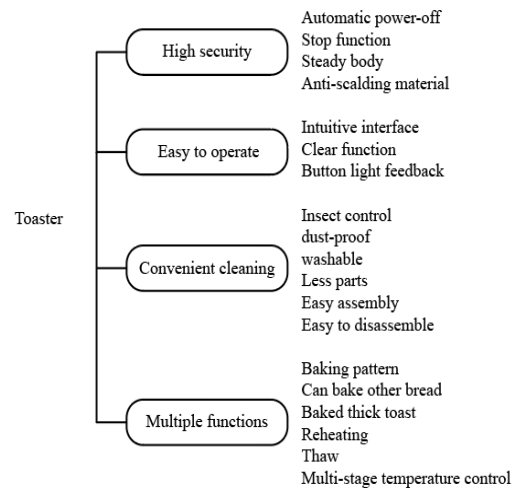

Fig. 4. Objectives tree

C. User behavior and interviews

The toaster is a small household appliance commonly used in the home. Therefore, the target group of the user is set to be a woman of the family around 40 years old, and observe the behavior pattern and the usage habits and problems through interviews. By observing the user's behavior, the following points can be drawn : 1. Pay more attention to the toaster interface and ease of operation in the hectic 2. Too busy to clean the inside of the machine 3. The amount of baking is

insufficient 4. The toaster is difficult to clean, too lazy to clean 5. It is very hot to take toast by hand.

D. Design goals and specifications

Based on the above data and methods, the toaster can be summarized into six important design goals and specifications : 1. Is it easy to disassemble and assemble? 2. Is the chip tray easy to clean? 3. Is the shape rigid and concise? 4. Is it easy to switch? 5. Is it easy to take the toast? 6. Is the baking device easy to clean?

E. Morphological chart

List the possible forms of the toaster (the way of taking the toast, the form of the stand, the form of the switch, the form of collecting debris), and obtain the morphological chart(Fig. 5). Combine these forms to get five Ideas(Fig. 6).

- Idea 1 : A1、B3、C1、D2 Idea 2 : A2、B1、C2、D2
- Idea 3 : A3、B2、C2、D1 Idea 4 : A4、B4、C3、D3
- Idea 5 : A5、B3、C2、D3

Taking toast	A	1	2	3	4	5
Stand	B	Bouncing	Drawer	Rotation	Wheel	Track
Switch	C	Press type	Knob type	Adjustment type		
Collecting debris	D	Cover type	Drawer type	Open type		

Fig. 5. Morphological chart

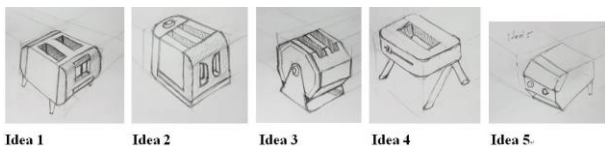

Fig. 6. Ideas

F. Concept assessment

This case uses the geometric averaging method in the AHP method to calculate the weight value. Pugh will be used to evaluate the best alternative. First, the AHP comparison matrix is applied to six design parameters : 1. Is it easy to disassemble and assemble? 2. Is the chip tray easy to clean? 3. Is the shape rigid and concise? 4. Is it easy to switch? 5. Is it easy to take the toast? 6. Is the baking device easy to clean? (Fig. 7). Then use the geometric mean method to calculate the weight. It is necessary to confirm whether the matrix is usable, confirm $C.R < 0.1$, and calculate $C.R = 0.093 < 0.1$, the matrix is available. Then proceed to Pugh. In this case, choose the toaster of Philips as the evaluation standard, compare the design idea with the design parameters, and then calculate the weight of the solution(Fig. 8).

$$Idea2(0.696) > Idea4(0.528) > Idea1(0.296) > Idea3(0.116) > Idea5(-0.123)$$

	A	B	C	D	E	F	NGM	Weight
A.Is it easy to disassemble and assemble?	1	0.333	5	0.333	0.333	1	0.755	0.100
B.Is the chip tray easy to clean?	3	1	5	3	0.333	3	1.886	0.250
C.Is the shape rigid and concise?	0.2	0.2	1	0.2	0.2	0.333	0.285	0.038
D.Is it easy to switch?	3	0.333	5	1	1	5	1.710	0.227
E.Is it easy to take the toast?	3	3	5	1	1	3	2.265	0.300
F.Is the baking device easy to clean?	1	0.333	3	0.2	0.333	1	0.637	0.084

Fig. 7. Pairwise comparison matrix

PUGH	W	PHILIPS	Idea1	Idea2	Idea3	Idea4	Idea5
Is it easy to disassemble and assemble?	0.1	S	+	-	+	-	-
Is the chip tray easy to clean?	0.25	+	+	S	+	+	+
Is the shape rigid and concise?	0.038	-	-	S	-	+	+
Is it easy to switch?	0.227	S	S	S	S	-	-
Is it easy to take the toast?	0.3	S	+	+	+	+	S
Is the baking device easy to clean?	0.084	+	+	-	-	-	-
Positive score		2	4	1	3	2	2
Negative score		1	1	2	2	3	3
Total score		3	3	-1	1	-1	-1
Weighted total score		0.296	0.696	0.116	0.528	-0.123	

Fig. 8. Pugh concept selection

G. 3D Modeling

Draw the shape and internal structure with Solidworks(Fig. 9) and render the material with Keyshot(Fig. 10). Then draw the engineering drawing(Fig. 11) to facilitate the subsequent processing and manufacturing operations.



Fig. 9. 3D Model



Fig. 10. Rendering

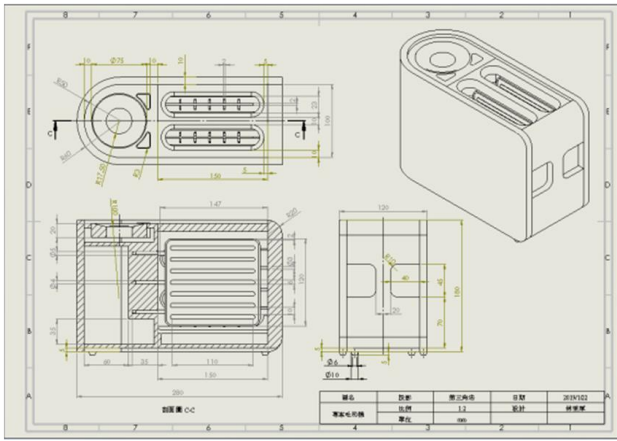

Fig. 11. Engineering drawing

H. Color planning

From the previous market research, we found that rigid and concise shape is an opportunity for the market. Therefore, we selected the blocks that conform to modern, serious and rational with the three-color hue and image scale developed by Nihon shikisai Research Institute(Fig. 12). It can be seen from the figure that it belongs to the lower right corner block, and then selects similar colors for color matching. There are six schemes(Fig. 13) and a non-color scheme(Fig. 14).

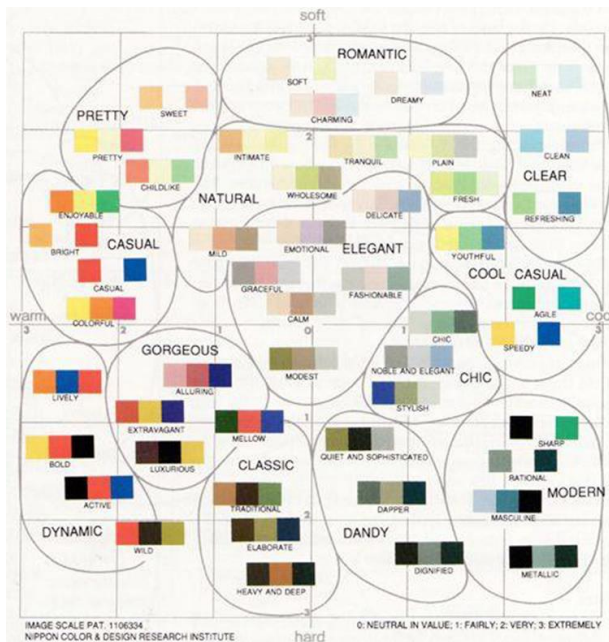

Fig. 12. Three-color hue and image scale



Fig. 13. Color schemes



Fig. 14. Non-color scheme

I. Color aesthetic calculation

First enter Photoshop to perform color capture of the Pantone color table, get RGB values, and then input the values into Munsell Conversion for conversion to obtain the value of Munsell HVC(Fig. 15). Then put this value into the formula and calculate it with the table to get the aesthetic value of each scheme(Fig. 16).

$$A.0.76398 > B.0.70796 > D.0.67416 > F.0.57673 > G.0.37303 > E.0.28205 > C.0.17413$$

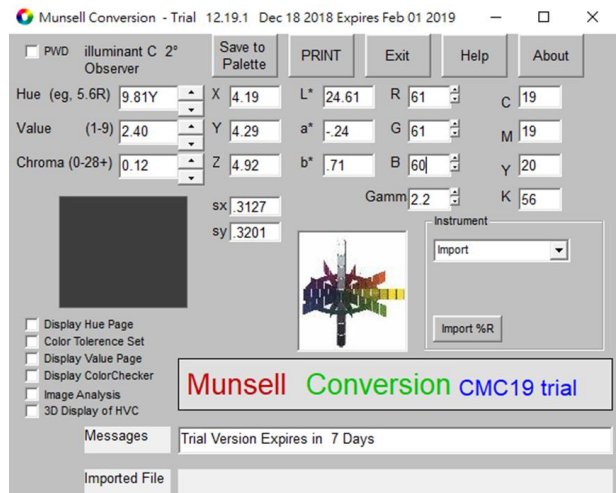

Fig. 15. Munsell Conversion

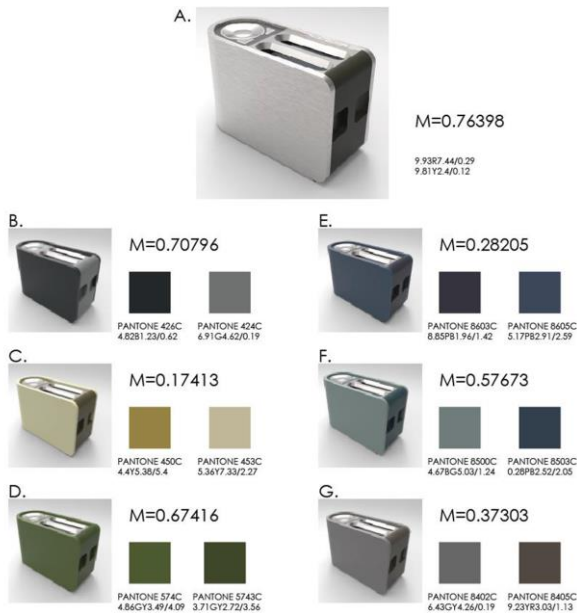

Fig. 16. The aesthetic value of schemes

IV. DISCUSSION AND CONCLUSION

This paper adopts the methods and concepts of concurrent engineering, integrating market research, product design, and computer-aided design. Conduct market research to confirm product opportunities, actually understand consumer needs and product shortcomings, and set design specifications and design goals. Consider design specifications and objectives into the design, and then perform Pugh assessment to bring the results closer to the design goals. The computer-aided design allows the product concept to be more fully present.

Finally, the color scheme is complemented by the aesthetic calculation, and the best color scheme can be obtained to facilitate the subsequent commercial manufacturing process.

REFERENCES

- [1] Cross, Nigel. (1994). *Engineering Design Methods*. New York : John Wiley & Sons.
- [2] Roosenburg, N.F.M., & Eekels, J. (1995). *Product Design Fundamentals and Methods*. New York : John Wiley & Sons.
- [3] Hsiao, S.W., & Ya-Chuan Ko (2013). A study on bicycle appearance preference by using FCE and FAHP. *International Journal of Industrial Ergonomics* .43, 264-273
- [4] Hsiao, S.W., & Hsin-Hung Lin (2018). A Study of the Evaluation of Products by Industrial Design Student. *EURASIA Journal of Mathematics, Science and Technology Education*. 14(1), 239-254
- [5] Hsiao, S.W. (2002). Concurrent design method for developing a new product. *International journal of Industrial Ergonomics*. 29, 41-55.
- [6] Subramanian, N., & Ramanathan, R. (2012). A review of applications of analytic hierarchy process in operations management. *International Journal of Production Economics*. 138(2), 215-241.

- [7] Hsiao, S.W., & Cheng-Wei Fan (1996). Integrated FSM, STM, and DFA Method on the Faucet Design. *Journal of the Chinese Institute of Industrial Engineers*. 13(3), 225-235.
- [8] Hsin-Yi Hsu (2005). A Method for Cloth-Color Match for Skin Based on Computer-aided Color Harmony. Master Thesis. National Cheng Kung University.
- [9] Chong-Shian Chen (2005). A Study on Color Aesthetic Applications of Mobil Phone Design. Master Thesis. National Cheng Kung University.