

RESEARCH ON INNOVATIVE DESIGN OF TEA PLANTING EQUIPMENT BASED ON FUNCTIONAL ANALYSIS

Peng Lu

*(Department of Industrial Design
Xi'an Academy of Fine Arts University
Xian, China; Department of Industrial Design
National Cheng Kung University
Tainan, Taiwan)*

Shih-Wen Hsiao

*(Department of Industrial Design
National Cheng Kung University
Tainan, Taiwan)*

Email: 417884366@qq.com

Abstract—The procedure of tea planting is very complicated, but the existing planting tools have many problems, such as single function, complex operation, low efficiency and poor continuity. On the basis of expert interview and field investigation, a tea planting equipment which integrates automation and multifunction is designed by functional analysis. Firstly, the detailed procedures of tea planting and the defects of existing planting equipment are learned by expert interview and field investigation. Then the functional system of tea planting equipment is divided into primary functional system and secondary functional system by functional analysis method, and the potential innovative possibility is explored according to the actual use of existing planting equipment. Finally, based on the analysis of the primary and secondary functional systems, an innovative and automatic tea planting and management equipment is designed. The design can improve the efficiency of tea planting activities, reduce the labor cost of tea merchants, and help to promote tea culture to the world.

Keywords—innovative design; tea planting equipment; function analysis method; automation equipment

I. INTRODUCTION

It is well known that throughout the world, Orientals like tea while Westerners like coffee. Tea culture is an important part of Chinese traditional culture. In recent years, with the improvement of China's comprehensive national strength, the influence of tea culture has spread all over the world, and the demand for tea in various countries has also increased significantly. In addition, considering that the tea planting process is extremely complex, and most of the existing planting tools are auxiliary tools, there are shortcomings such as single function, complex operation, low efficiency and poor continuity, and there is no automatic planting and management equipment on the market. In order to meet

the growing demand for tea, it is necessary to design an automated tea planting equipment to improve the efficiency of tea planting and reduce the labor costs in the planting and management stages.

The complexity of tea planting activities is reflected in the need for different means of operation at different times, such as plowing, sowing, weeding, pruning, cutting and so on. In order to master the problems involved in the process of tea planting, this study clarified the potential design problems by expert interview and field investigation, and then explored the possibility of innovative design. In the process of developing new products, it is very important to accurately grasp the function system of products. The function system of the product is a "black box". The function analysis method can whitewash the function system of the product, so as to find the appropriate elements to achieve each function. Therefore, this paper takes the functional analysis method as the main research means, dissolves the functional system of the target product into the primary and secondary systems, then carries on the detailed analysis, and finally designs an innovative tea planting and management equipment.

II. ANALYSIS ON THE PRESENT SITUATION OF TEA PLANTING

China's tea garden area and tea output rank first in the world [1], and tea planting has a history of more than 3000 years. Now the tea industry has entered a period of rapid development. In the process of development for many years, a set of unique planting methods and processes have been gradually formed. In recent years, under the influence of economic globalization and the change of people's way of life, the development of "tea culture" was once impacted by new drinks. However, with the improvement of China's comprehensive national strength, more and more people around the world take the initiative to try and experience tea, so the demand for tea is gradually increasing. Therefore, if we can further improve the efficiency of tea planting and the quality of tea, there will be huge business

opportunities for the majority of tea merchants.

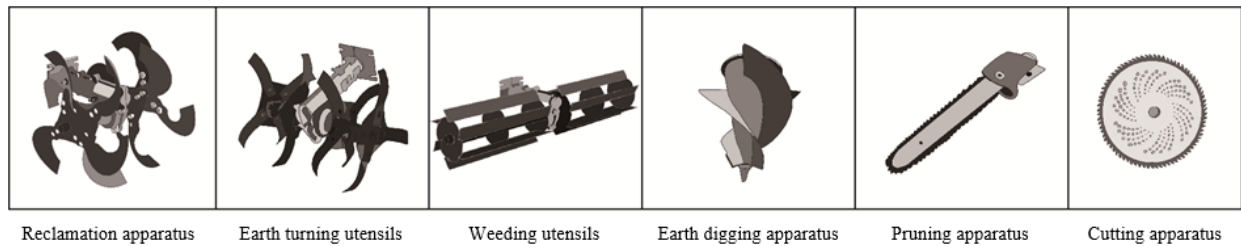

Fig. 1. Existing auxiliary equipment for tea planting.

Nowadays, because the process of tea planting is extremely complex, a large number of auxiliary devices are needed in the process of tea planting, as shown in Fig. 1, such as hole opening utensils, earth turning utensils, weeding utensils, digging utensils, pruning utensils, etc. However, each appliance has the problem of single function and low efficiency, which requires a large amount of manpower to operate and use. In addition, with the vigorous development of China's primary industry, the contradiction between employment and labor has been aggravated, and the human cost paid by tea merchants has gradually increased, thus increasing the cost of tea production, which to a large extent limits the development of the tea industry.

There is a close relationship between planting technology and the quality of tea [2]. Efficient planting technology can not only improve the quality of tea, but also improve the efficiency of tea planting and tea management. At the stage of tea planting, it can reduce costs and increase the income of tea merchants. Therefore, intelligent and automatic tea planting equipment is particularly important. Effective tea planting machinery can not only improve the speed of tea planting, but also manage the process of tea planting in a unified way so as to improve the quality of tea. It can meet the needs of various scales of tea plantations, such as family type, workshop type, etc.

III. APPLICATION OF FUNCTIONAL ANALYSIS METHOD IN PRODUCT DESIGN

A great deal of practice shows that the product innovation mainly comes from the innovation of the function definition and working principle involved in the scheme design stage[3]. Therefore, in the stage of new product development, we should attach great importance to the functional analysis of the product. The definition of function must be conducive to revealing the most essential things in the function, in order to broaden the creative ideas and find a more ideal way to solve the problem [4]. The function analysis method is to regard the function of the target product as a "black box" and convert a certain "input" into the "output" of the target [5]78-81, as shown in Fig. 2. Therefore, the black box should reflect the overall function of the product as much as possible and broaden

its "functional system boundary" as much as possible. Functional analysis method is a very important scientific research method in the field of modern mechanical design. Some scholars have successfully applied functional analysis method to the design of automatic packaging machine [6] and fire fighting vehicle [7]. It has been proved that this method is suitable for the product design of the continuous operation system, such as packaging bulk carpet into bales. It is also suitable for the design of household appliances products, such as washing machine design. The input is dirty clothes, and the output is clean clothes. The function of black box includes loosening stains, separating stains, removing stains and removing moisture. It further widens the system boundary and can add dry clothes and flattening clothes to the function of black box.

The specific operation steps of the function analysis method are as follows.

- Define the whole function of "black box" based on "input" and "output", and widen the system boundary as far as possible.
- Decompose the overall function into a series of necessary secondary functions.
- Draw the secondary function block diagram to show the relationship between them.
- Draw the system boundary.
- Find the appropriate elements to achieve the correlation between the secondary functions.



Fig. 2. Function "Black Box" .

IV. ANALYSIS OF CONCEPTUAL DESIGN SCHEME

A. Design positioning

Considering the design orientation of tea planting equipment from the topographic factors. According to the calculation of tea planting area and population status of each province in China, it can be concluded that the

main tea producing areas in China are located in Zhejiang Province, Anhui Province, Hunan Province, Sichuan Province, Fujian and other provinces [8]. These areas have limitations in the use of tea planting equipment due to different topographic factors. Generally speaking, the topography of tea planting can be roughly divided into four types, including terrace type, mountain type, plain straight line type and plain curve type. Among them, terraces are more complex and vary according to the shape of the mountain, so it is difficult to meet the automatic tea planting. Therefore, the main design reference factors in this study are plain straight line and plain curve topographic factors. These two topographic factors cover the characteristics of tea garden topography in most areas of China and have high universality.

Considering the design orientation of tea planting equipment from the scale of tea planting. China is the source of the "tea culture" and has a history of nearly 5000 years. In the process of development, the planting scale with Chinese characteristics has been formed, including family type, workshop type and contract type. Because of the complexity of tea planting process, tea planting of various scales still depends on manual work, and this mode is lagging behind the rapid development of agriculture and no longer adapts to the development of the times. In addition, due to the different climate and soil conditions in different regions, the scale of tea planting also has its own characteristics, so different regions and different scales of tea planting should adopt the technology strategy of adapting to local conditions

[9]. In order to achieve the goal of automation and intellectualization of tea planting, tea planting equipment should meet the needs of various scales of tea plantations.

In summary, the product development and design of tea planting equipment should consider the topographic and scale factors of tea planting comprehensively, and then reflect the required functional system, and should widen the boundary of its functional system as far as possible.

B. Primary functional system analysis

On the basis of the previous design and positioning, the primary functional system framework of tea planting equipment is clarified by functional analysis. In addition, the process of the whole function system is systematically planned in combination with the data obtained from the prior expert interview and the field investigation, and further ensures the scientific and reasonable of the function system of the tea planting equipment. The primary function system includes a series of secondary functions such as land reclamation, soil plowing, sowing, watering, fertilization, weeding, pruning, cutting and so on. As shown in Fig. 3, the tea seedlings are used as the input of the function black box, and the unprocessed tea leaves are used as the output. Finally, according to the growth cycle of tea, the primary functional system can be divided into three secondary functional systems, including sowing, fertilizer and pruning.

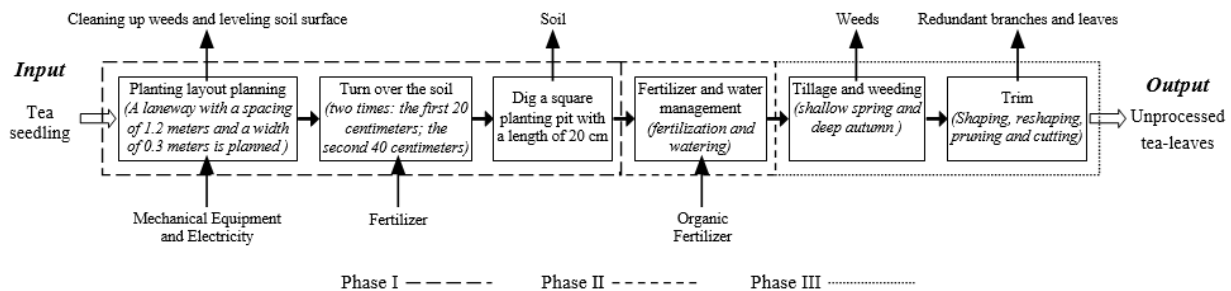

Fig. 3. Analysis of the primary function system of tea Planting equipment.

C. Secondary functional system analysis

Considering the complexity of tea planting process, in order to further clarify the secondary functions of tea planting equipment, the primary function system is broken down into three more detailed secondary function systems. The three secondary functional systems are established based on the actual growth cycle of the tea, as shown in Fig. 4 to Fig. 6. Based on the analysis of the primary function system and the secondary function system, this research clarifies the various functions required by tea planting equipment, and then finds the appropriate elements to realize the correlation between the functions, and finally obtains the design solution that meets the requirements of the functional system.

Through the analysis of the secondary function system, the functions of tea planting equipment are described as follows.

1. *Planting layout planning:* Land reclamation, plan the layout of tea garden, and reserve the tea channel and the sidewalks on both sides.
2. *Turn over the soil:* In the early stage of planting, it is necessary to flip the soil twice, the first deep ploughing 20 centimeters, the second deep ploughing 40 centimeters.
3. *Dig a planting pit:* Dig a square planting pit with 20 centimeters in the middle of the tea ceremony, then place the tea seedlings and apply 50g bottom fertilizer at the same time, and finally cover the soil.

4. *Spread manure*: In late March, early May and late July, topdressing, basal and foliar fertilization were applied.
5. *Disease and insect prevention and management*: The prevention and management of tea pests should follow the principle of "prevention first, comprehensive management" [10].
6. *Irrigate*: It is divided into leaf irrigation and ground irrigation.
7. *Weeding*: Shallow tillage and weeding were carried out in February and March of the following year.
8. *Prune*: In the early stage of the growth of the tea, proper pruning can be carried out to achieve the

effect of finishing the crown, and the top-end advantage can be prevented. During the mature period of tea, light pruning and deep pruning are carried out. Among them, light pruning is to cut off redundant branches and leaves once a year. The object of deep pruning is the residual leaves and dead branches appearing in the crown. Its purpose is to improve ventilation and photosynthesis, so as to promote the growth of tea and obtain more high-quality tea [9].

9. *Cutting*: When the tea plant enters the senile stage, it needs to be cut and removed first, and then re-planted.

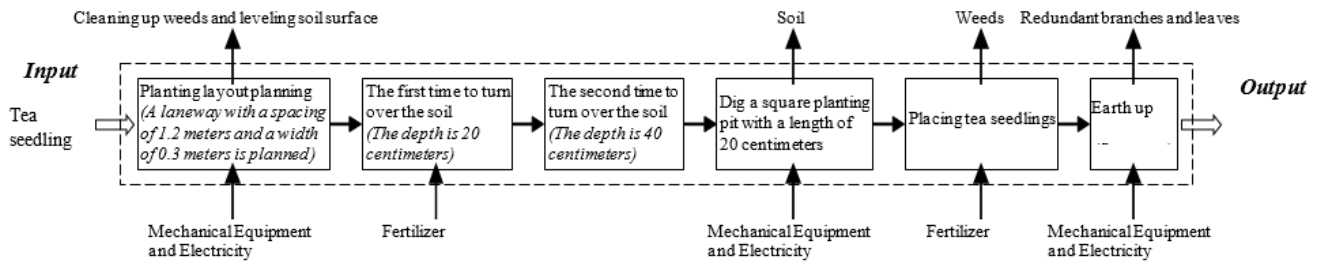

Fig. 4. Phase I.

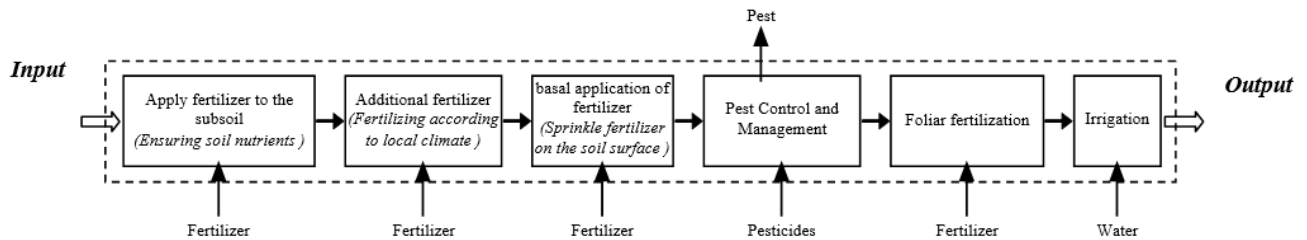

Fig. 5. Phase II.

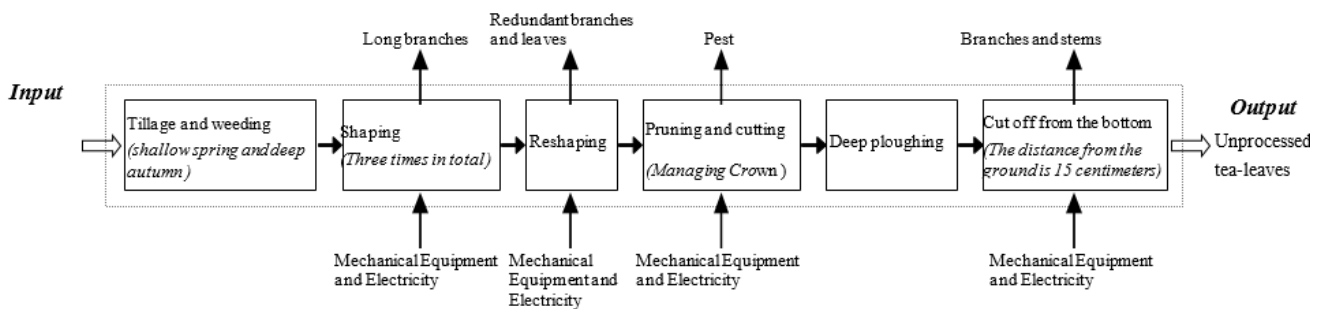

Fig. 6. Phase III.

To sum up, this article makes a detailed and systematic analysis of the primary and secondary functional systems of tea planting equipment, on the basis of which we find suitable elements for innovative design.

D. Detailed design instructions and demonstrations

"Function determines form" or "Form follows function" is the basic principle of product shape design. Based on the previous functional analysis, the proposed

conceptual design scheme can meet the diverse functional requirements of tea seedlings in different growth cycles. Detailed conceptual design rendering effect diagram as shown in Fig. 7, the specific description is as follows.

- The pre-modular device can change different tools by rotating according to the requirement.
- The rear-mounted manipulator can meet the pruning requirements of different periods.

- The center-mounted lifting mechanism can meet the vertical movement of the equipment.
- The bottom device includes several functions such as digging, sowing and covering soil. The supporting units are divided into tyres and crawlers, in which the tyres ensure the free steering of the equipment and the crawlers ensure that the equipment moves forward and works on the soft soil.



Fig. 7. The rendering effect diagram of conceptual design.

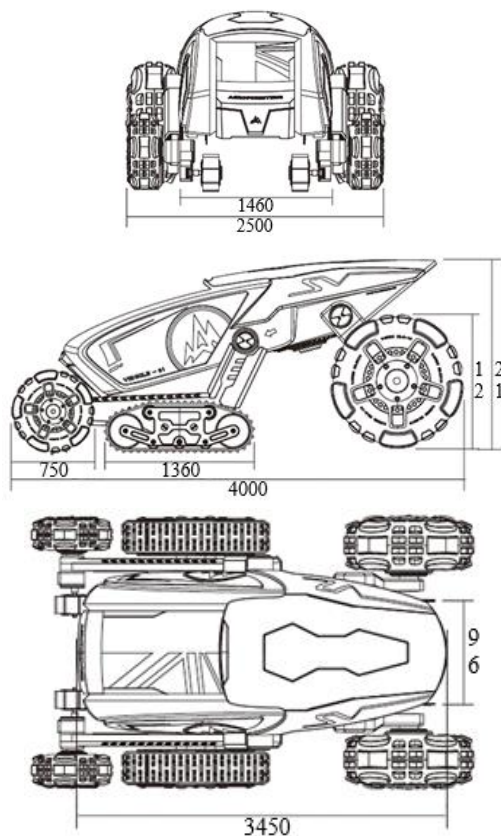

Fig. 8. Size description of conceptual design scheme.

Considering the use environment of tea planting equipment and the spatial layout of each component, the final product size is determined, as shown in Fig. 8. In order to ensure the portability and flexibility of the equipment, the size of each dimension is guaranteed to be minimum as far as possible under the allowed conditions. The equipment is 4 meters long, 2.5 meters

wide and 2.12 meters high; Considering the height of the mature tea plant, the maximum height of the chassis of the equipment is 1.2 meters from the ground, which is enough to ensure that the equipment advances above the tea plant; Considering the overall layout of tea garden, the maximum width of the tire is 0.5 meters, which can meet the requirements of equipment running between tea bushes.

V. CONCLUSION

Based on the actual demand of China's tea industry, this article proposes an innovative tea planting equipment. Through expert interviews and field surveys, the potential design needs in the planting process were identified, and the detailed design positioning was obtained. Then, the function system of tea planting equipment is further clarified by functional analysis method, in which the whole function system of tea planting equipment is broken down into three secondary function systems, which is helpful to find the appropriate elements to realize the correlation between various functions, and then get the best design solution.

In order to meet the development direction of global science and technology agriculture, the tea planting equipment is an innovative agricultural equipment which integrates automation and intelligence. On the one hand, it makes up for the shortcomings of the existing auxiliary equipment, such as single function, complex operation, low efficiency and poor continuity; On the other hand, systematic and scientific management model can improve the quality of tea, which is of great economic significance to the vast number of tea merchants in China. In addition, the use of automated tea planting equipment can reduce the cost of tea and help China's "tea culture" to move to every corner of the world.

ACKNOWLEDGMENT

The authors are grateful to the reviewers for their helpful comments.

REFERENCES

- [1] H.X. Song, "Effects of Different Organic Fertilizer Treatments on Tea Garden Soil", Shaanxi: Northwest A&F University, 2011
- [2] Z.D. Deng, "Thoughts on Tea Planting Technology and Promotion Strategy," *Journal of Seed Science and Technology*, pp. 28, June 2019.
- [3] A.N. Gou, "Functional Analysis in Mechanical Innovation Design Heilongjiang Ecology," *Journal of Heilongjiang Vocational Institute of Ecological Engineering*, vol. 30, pp. 35-36, March 2017.
- [4] X.Y. Lin, X.Y. Li, and H. Peng, "Application of TRIZ Theory in Mechanical Engineering Training of College Students," *Laboratory Science*, pp. 136-139, April 2018.
- [5] N. Cross, *Engineering Design Methods*, 3rd ed., vol. 4, New York: John Wiley & Sons, 1994, pp. 78-81.
- [6] F. Wang, and Z.W. Wang, "Design of automatic packaging machine for PVC gusset plate based on

- functional analysis,” *Packaging engineering*, pp. 208-213, September 2017.
- [7] Y. Li, and Z.W. Cheng, “Design of a minitype firefighting truck based on function analysis,” *Manufacturing Automation*, vol. 40, pp. 88-91, February 2018.
- [8] X.P. Wang, “Analysis of the competitive advantage of China's tea industry field-based on the perspective of industrial agglomeration,” *Tea in Fujian*, pp. 287, May 2018.
- [9] H. Xie, “Discussion on Tea Planting Management Technology in Mountainous Areas,” *South China Agriculture*, vol. 11, pp. 37-39, December 2017.
- [10] A.X. Xie, Q.M. Gao, and J.C. Zhou, “Effective Management of Tea Planting in Mountainous Areas,” *Agriculture of Jilin*, pp. 108, April 2018.