

# Intelligent Warehouse Management Design

Shen Wang\*, Shuqing Wang

Hubei university of technology, Hubei, China

\* 454110191@qq.com

**Abstract.** Along with the rapid development of national economy, Intelligent warehouse in all walks of life will get more and more widely. Automatic warehouse system of modern logistics system is an important part of, is widely used in industries. At present, it has become the enterprise production and management, one of the symbols of information. The system adopts PLC controlled by PLC, the output pulse signals to control the operation of the step-motor between through the stepping motor drive connections, also used as some sensors, micro switch and reflex sensor. Automated warehouse is an important part of the rapid development of modern logistics system. It has the advantages of saving land, reducing labor intensity, eliminating errors, improving the level of warehousing automation and management, improving the quality of management and operation personnel, reducing storage and transportation losses, and effectively Reduce the backlog of liquidity, improve logistics efficiency and many other advantages.

**Keywords:** Automatic warehouse system, enterprise production and management, eliminating errors.

## 1. Background of Paper Design

With the development of modernization, the various industry arises at the historic moment, we are also more and more demand for all kinds of things, also more and more extensive, circulation of commodities is becoming more and more broad[1].

The result of the development of material storage, storage materials in the warehouse, but our need for warehouse is becoming more and more big, the warehouse must also along with the development of The Times and continuous development, the development of productivity and progress. In the process of commodity circulation, warehouse is indispensable, which ensures the storage of goods. Warehouse is an important link to realize the value-added service function of logistics. Warehousing activities play a role in the national strategic reserve and are necessary conditions for the smooth development of the society in the production process. In the real market, there are various forms of warehousing in the development process. In order to occupy a certain share in the market, enterprises must do a good job in warehousing. Only by doing the most basic, can they improve the subsequent economic benefits.

Stereoscopic warehouse has a very high volume utilization rate, The inbound and outbound flow is also very orderly, using computer control to facilitate the actual control of the enterprise, modern controls, and other characteristics, it has become the indispensable storage capabilities, enterprise logistics and production control and has become more and more in the development of The Times the emphasis of the enterprise. Through the study of the logic control system of relay, PLC has been developed in contemporary times, which has absolute advantages in digital processing and sequence control. Relay generally has two functions, one is logic operation, the other is the strong electric weak control. Programmable logic controller, referred to as PLC, is a new industrial control equipment[2]. It has the advantages of convenient design, quick installation and less maintenance work. Short development cycle, with a high success rate; It occupies a small space, but also a small weight, power loss is also small, in general, its function is relatively perfect, good versatility. And it has been used in many areas of automation, as a drive to complete the production of automation pillar products. It is more reliable than relay systems; It also occupies a much smaller space than the relay system; It is also comparable in cost to relay systems; It is easy to change procedures directly on site; Convenient use, maintenance, maintenance, etc. Can directly push the solenoid valve, and the corresponding actuator contact; Can be to the central executive agency and so on a series of advantages. Therefore, if by the

PLC control of the three-dimensional warehouse this technology can mature, will produce significant economic value.

## 2. Basic Structure of Three-dimensional Warehouse

The main body of the warehouse is composed of four storehouses with 16 positions, moving machinery and electrical control.

The plane layout of the three-dimensional warehouse is shown in figure 1.

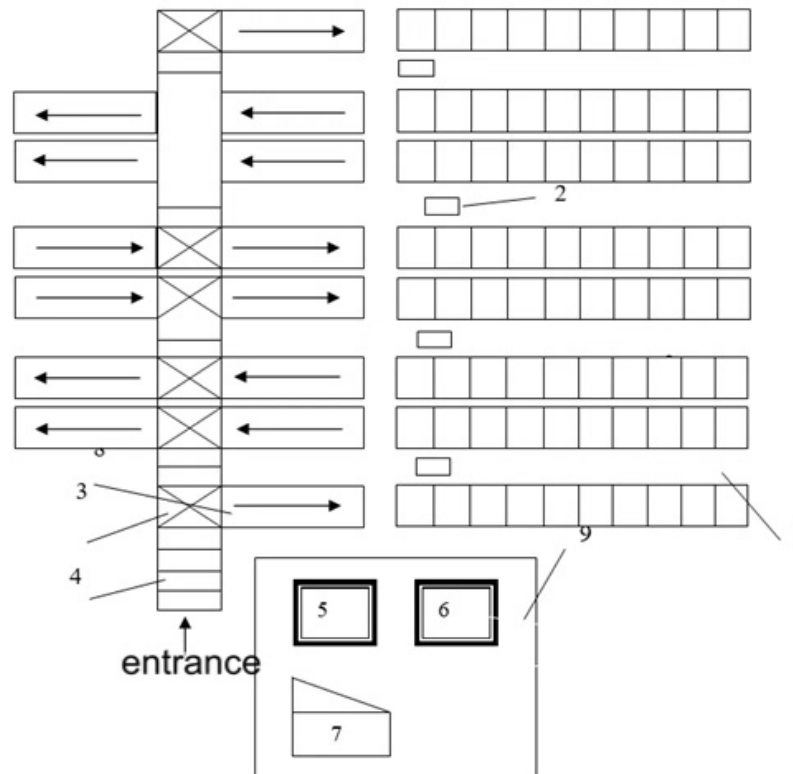

1 shelf 2 track roadway stacker 3 chain conveyor 4 lift 5 monitoring computer 6 management computer 7 conveying system manual operating platform 8 raceway conveyor 9 central control room

Figure 1. Layout of the three-dimensional warehouse

### 2.1 Hardware Principle of Three-dimensional Warehouse

#### 2.1.1 Principle of Stepper Motor

Stepper motor is a kind of control element.

When the system adds an electrical pulse to the stator winding, the rotor turns a step Angle. When the electric pulse is added to the motor according to a certain phase sequence, the number of steps of the rotor in a certain direction of rotation is equal to the number of electric pulses. Therefore, the displacement can be changed by changing the number of input pulses; In order to control the position, the direction of rotor motion can be controlled by changing the excitation phase sequence of the input pulse. When the electric pulse is continuously applied in a certain phase sequence, the rotor will rotate in one direction at a rate directly proportional to the frequency[3]. Therefore, by changing the frequency of the electric pulse and the phase sequence of the power supply, the speed and direction of the motor rotation can be changed, so as to further complete the control within the large scope. This stepping motor control function, compared with other motors, is unique. Its phase number can be divided into several types. The increase of phase number can make the performance of stepper motor

better. However, the construction of the motor will become more complicated and the cost will become more.

### 2.1.2 Principle of Stepper Motor Driver

Stepper motor drive circuit based on signal action, when the movement is relative to the sensor, after comparing with original signal reflection signal, can lead to frequency shift, and then through the integrated circuit, weak frequency shift signal will be amplified, and then by doppler detection, amplification, clipping, eventually to achieve related to cargo moving signal dc signal output level[4].

### 2.1.3 Motor Layout

According to the design requirements, the classification of motors is as follows:

- 1) Control the motor of horizontal transmission chain
- 2) Control the motor of the upper and lower transmission chain, and install "photoelectric sensors" on both sides of the transmission chain.

## 2.2 Determination of Technical Parameters of Three-Dimensional Warehouse

Table 1. Specific parameters of three-dimensional warehouse

The heaviest item at the delivery/delivery counter	20Kg
Height of each position	4.5CM
The height of a position	0.5CM
The parallel distance of a position	0.5CM
Volume of space	4M <sup>3</sup>
Programmable logic controller (PLC) power supply	24V DC

## 2.3 Selection of Stepping Motor

Stepping motor selection needs to consider step Angle, there are holding torque, braking torque and other characteristics.

In the selection of stepping motor, the first consideration is the type selection of stepping motor, followed by the selection of specific varieties. In the control system of the three-dimensional warehouse, the stepping motor is required to have low voltage, low current, positioning torque and positioning device with bolt mechanism. Step Angle, driving voltage, rated voltage, current and holding torque should be considered comprehensively to determine the specific specification and control device of stepping motor. So choose according to need, 17 hs4417 motor, its step precision is + / - 5%, maximum temperature is 80 °C, environment temperature range for - 20 °C to+ 50 °C .

Table 2. The electrical technical data of this stepping motor

Motor model	Step from the Angle of	The rated voltage	Rated current	Hold the torque	Brake
17HS4417	1.8 <sup>0</sup>	2.55V	1.7A	40N.cm	2.2N.cm

### 2.4 I/O Address Assignment Table

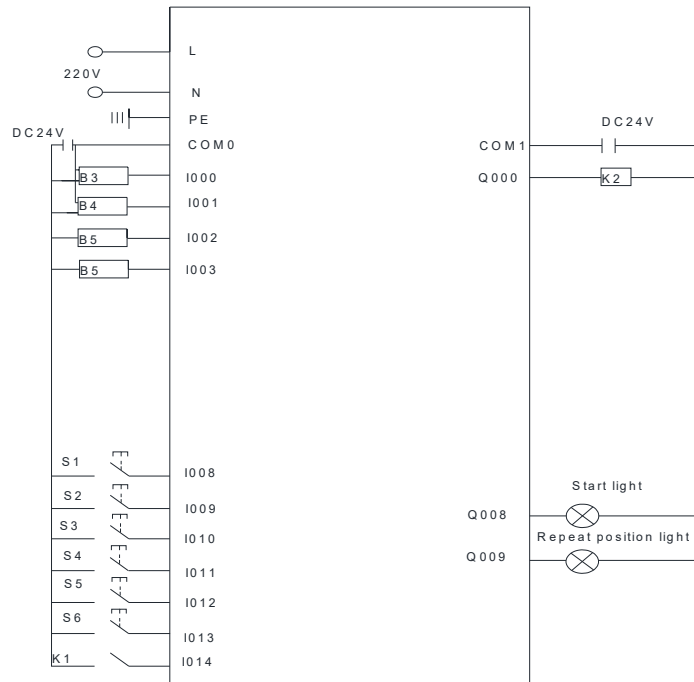

Figure 2. I/O address assignment table

### 2.5 Ladder Diagram Designed by PLC

When the goods are stored in the warehouse, they need to be put into different positions according to the selection.

Therefore, we set the control of X and Y axes in the chain transmission mechanism. By controlling the upper, lower and left and right of the transmission mechanism, the goods can be transported to the selected position and stored.

Electricity, X,Y axis reset respectively, when the goods sent to the lift tables, began to action, due to the selected position is different, when receives the pulse, the X axis and Y axis to different actions, to increase or decrease according to the requirement, then around mobile, choosing the right location for storage.



(a)

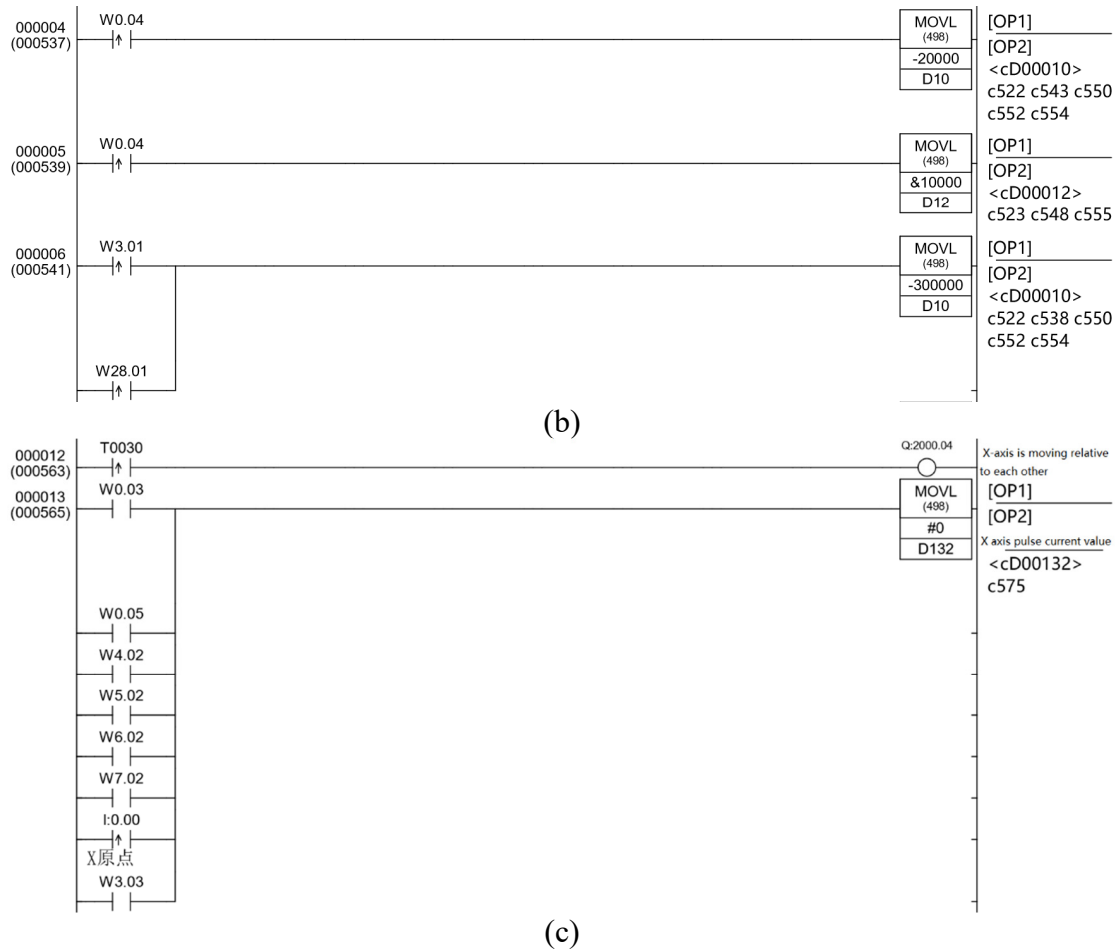

Figure 3. Ladder diagram designed by PLC

### 3. Conclusion

In the process of this design, I re-recognized the PLC in the modern industrial production of extensive use, and its various other controllers can not compare the advantages.

For example, high cost performance, broad applicable areas, strong environmental adaptability, versatility, easy to use, high flexibility with continuity, periodic work characteristics. With the development of industrialization, PLC technology has become more and more mature, its application in a variety of two areas is also more and more, becoming more and more important.

The whole design from the initial theoretical knowledge to the final practical operation, which involves the field including: programmable controller principle and application, stepping motor principle and application, modern logistics development trend and so on. Through searching a lot of materials, I understand the important position of three-dimensional warehouse in modern industrial production. With the increase in the number of enterprises, the competition is also increasingly big. Enterprises must have more technological innovation in three-dimensional warehouse to have the core competitiveness to strive for a bigger market position and better development prospects.

### References

- [1]. Deng Mingxing. Development of Automated Warehouse Management System[A]. Proceedings of 2018 2nd International Conference on Electronic Information Technology and Computer Engineering (EITCE 2018) [C].2018:6.
- [2]. Dong haitao. Early stage of ERP system launch -- how to strengthen warehouse management in enterprises [J]. Materials management, February 2008, ship materials and market, 33-34.

- [3]. Jia guizhu, zhang liping. Importance of warehouse management in material management [J]. Modern logistics technology, 2009.
- [4]. Rob Glidden, Cameron Bockofick.et1.Design of Ultr a. LowCost UHF RFID Tags for Supply China Applications[J]. IEEE Communications Magazine, August 2004.