

Dimensions of Early Childhood Character Education in Facing Industry Revolution 4.0

Harun
Faculty of Education
Universitas Negeri Yogyakarta
 Yogyakarta, Indonesia
 harun@uny.ac.id

Amat Jaedun
Faculty of Engineering
Universitas Negeri Yogyakarta
 Yogyakarta, Indonesia
 amat_jaedun@uny.ac.id

Abdul Manaf
Graduate School
Universitas Negeri Yogyakarta
 Yogyakarta, Indonesia
 Abdulmanaf.2017@student.uny.ac
 .id

Sudaryanti
Faculty of Education
Universitas Negeri Yogyakarta
 Yogyakarta, Indonesia
 sudaryanti@uny.ac.id

Abstract—This study aims to determine the dimensions of the character of early childhood relationships with oneself, in an effort to face the challenges of industrial revolution 4.0. Research locations in the area of Central Java Province, specifically Ex Kedu Residency. The research subjects were 489 children from 28 PAUD institutions. The research method used is quantitative. The analysis used is a confirmatory factor analysis. The results were obtained that the dimensions of character relating to yourself consist of honesty, discipline, responsibility, and independence. All of these indicators contribute to the child's attitude or behavior towards themselves. Based on the biggest factor loading value, dominant responsibility indicators are obtained in the character of early childhood. Character values formed or developed can be used as strength of character values in the face of the industrial revolution 4.0

Keywords: *character education, early childhood, Industrial Revolution 4.0*

I. INTRODUCTION

The industrial revolution 4.0 has led many changes so fast and competitive in various sectors of life including the world of education. The world economic forum states that the industrial revolution is characterized by a fusion of technology. For example artificial intelligence, robotics, the internet of things, autonomous vehicles, 3-D printing, nanotechnology, biotechnology, material science, energy storage, and quantum computing [1], so that it is required to be able to prepare and equip future generations especially students with various skills.

Life in the 21st Century requires a variety of skills, a minimum of three skill categories: literacy, competence, and character quality. The picture of life in the 21st Century is reflected in the results of a survey conducted by the World Economic Forum (2015). The survey results produced 16 skills in 3

categories, namely: foundation literacy, competencies, and character qualities [2].

The three categories of skills that must be possessed are explained as follows: (1) foundation literacy, namely the ability to use core skills for everyday life which consist of: literacy reading, numeracy, science literacy, ICT literacy, financial literacy, cultural literacy and community; (2) competencies (competencies), namely the ability of students to solve complex problems consisting of: critical thinking, creative, communication, and collaboration. (3) character qualities describe the behavior of students facing their environmental changes which consist of curiosity, initiative, persistence, adaptability, leadership, social and cultural sensitivity [2].

Based on the three skills that exist, in Indonesia, character quality is very important. The Indonesian government, in this case, President JokoWidodo has made character development a priority program. Character education is emphasized to be done in all aspects of life. In schools specifically carried out programs called strengthening of character education [3]. Character education aims to form and build the mindset, attitudes, and behaviors of the children to be positive, moral, noble, and responsible. In the context of education, character education is a conscious effort carried out to shape children into positive individuals and have moral character according to competency standards, so that they can be implemented in daily life.

In the industrial revolution 4.0 character education is very much needed and is considered very urgent, so students can use technology wisely. Character education is very much needed since early childhood. Characters that are formed or developed from an early age, will produce character strength as adults. With the strength of character, it will not be easy to

experience degradation or crisis of character and wise in utilizing technology.

Early childhood character education is held before the basic education level through formal, non-formal, and/or informal education. In the context of formal education can be in the form of kindergarten (TK), and *raudhatul athfal* (RA), and other forms of equal. While in the non-formal path can be in the form of a play group (KB) and child custody (TPA), as well as other forms of equals, while the informal education path is in the form of family education or education organized by the environment [4].

Still in the context of a variety of early childhood education, in ASEAN countries, for example in Pilihina in the form of a childcare center under the auspices of the Family Development Program (FDP) which fosters children aged 0-3 years, and Early childhood Care Development (ECCD), this program conducted for 2 years starting at the age of 7 years. In Vietnam, child care centers and kindergartens are under the auspices of early childhood care and education (ECCE) [5].

Early childhood education does not only fulfill human rights to get education as early as possible through formal, non-formal and informal channels, but also as a foundation for the growth and development of all children's potential. The objectives of early childhood education are: (1) children are able to worship, know and believe in God's creation and love their fellow humans; (2) children are able to think logically, critically, give reasons, solve problems and find causal relationships; and (3) children are able to recognize the natural environment, social environment, the role of society and appreciate social and cultural diversity and be able to develop self-concepts, positive attitudes towards learning, self-control, and a sense of belonging more [6].

Early childhood character education must be based on the principles that exist in character education. The principles referred to are: (a) promoting basic ethical values as a basis for character; (b) identify characters comprehensively so that they include thoughts, feelings, and behavior; (c) use a sharp, proactive and effective approach to character building; (d) creating a school community that has care; (e) provide opportunities for students to show good behavior; (f) has a meaningful and challenging curriculum that values all children, builds their character, and helps them succeed; (g) strive for self-motivation in children; (h) functioning all school staff as moral communities who share responsibility for character education and are loyal to the same basic values; (i) there is a division of moral leadership and broad support in developing character education initiatives; (j) functioning of the family and community members as partners in the effort to build character; (k) evaluating the character of the school, the function of

school staff as character teachers, and the manifestation of positive character in the lives of students [7].

Character education in early childhood is one of the alternative choices or a good starting point in anticipating the development of technology and information in the industrial revolution 4.0. Children have been introduced to science and technology based learning. The use of technology wisely if based on good character. To realize this, the character values need to be integrated into the curriculum.

In the context of character values that must be instilled in early childhood, specifies the character values that must be built for early childhood including: honest; reveal the contents of the heart; not hurt each other; mutual help; return goods in their place; talking turns; give friends the opportunity to opine; queued up; mutual respect; speak well and politely; listening to other people talk; modeling behavior, so that efforts to develop the character education dimension as a strategy for implementing multicultural-based character education are very important in PAUD. The development of the dimensions of character values education is integrative, compact and consistent. Integrative means integrating character education into all programs and activities. Compact means all components of education have the same attitude and outlook in implementing character education. Consistent means all components of education have attitudes and views that are consistent in implementing character education in PAUD [8].

Planting these character values is a very difficult thing. Therefore, at the PAUD level a number of main character values are selected which are summarized from the points of SKL PAUD (Ministry of Education Regulation Number 23 of 2010) and SK/KD (Ministry of Education Regulation Number 22 of 2010). Ministry of National Education 2010, Character Education in PAUD, Directorate General of Primary and Secondary Education Management Directorate of Secondary School Development; The following are aspects of the main characters referred to and briefly described: (1) character values in relation to divinity: one's thoughts, words, and actions are always based on divine values and/or religious teachings, (2) character values in relation to oneself: honest, tolerance, discipline, hard work, creative, independent, democratic, curiosity, national spirit, love for the country, respect for achievement, friendship, peace of mind, love to read, caring for the environment social care, responsibility, (3) character values in relation to others: be aware of the rights and obligations of themselves and others; comply with legal and customary rules; respect the work and achievements of others; polite behavior of fellow people, (4) the value of the character's relationship with the environment: attitudes and actions that always strive to prevent damage to the surrounding natural environment, always wanting to provide

assistance to others and the public that needs, and (5) nationality value; ways of thinking, insights that place the interests of the nation and state above self and group interests; nationalist; respect diversity [7].

II. RESEARCH METHOD

This study uses a quantitative approach. The design of this study examines the dimensions of character determination of early childhood. The research location was in the area of Central Java Province, specifically Ex Kedu Residency. The research subjects are shown in Table 1 below.

TABLE I. NUMBER OF RESEARCH SUBJECTS

Municipal / Regency	PAUD	Sample
Magelang	6 PAUD	100
Kebumen	7 PAUD	125
Temanggung	8 PAUD	138
Purworejo	7 PAUD	126
Total	28 PAUD	489

The dimensions of character education related to oneself consist of: (1) honesty, (2) discipline, (3) responsibility, and (4) independence. The instrument for collecting data uses a questionnaire sheet filled in by the teacher. The instrument is used to collect data on the dimensions of character education for early childhood related to themselves. The instrument contains 12 items that measure 4 indicators, namely: honesty (KJ), discipline (DS), responsibility (TJ), and independence (KM).

Quantitative data obtained were analyzed by confirmatory factor analysis (CFA) with a second-order approach. Use the LISREL 8.50 program, to facilitate the analysis process. The criteria used to express the fit kostruk model (model fit), there are three types of measures of goodness of fit namely absolute fit indices, incremental fit indices, and parsimony [9], [10].

III. RESEARCH RESULT

Based on confirmatory factor analysis results were obtained as shown in Fig. 1, Fig. 2, Fig. 3, and Fig. 4.

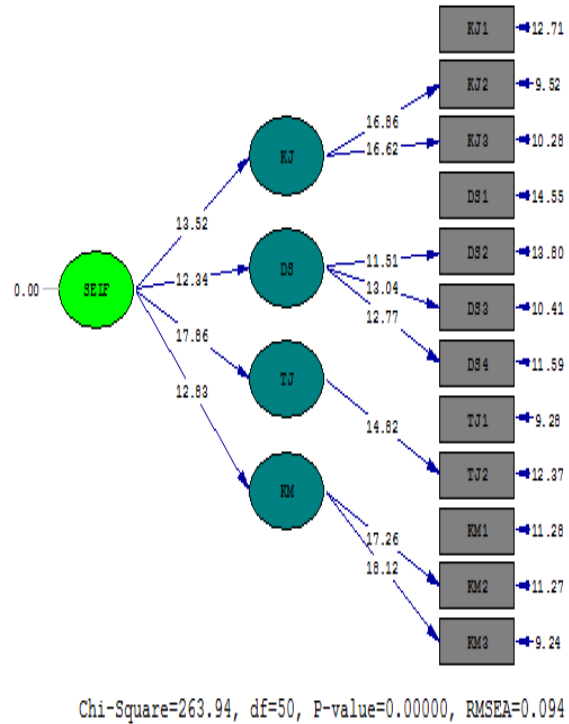

Fig. 1. CFA second-order diagram based on standardized solution

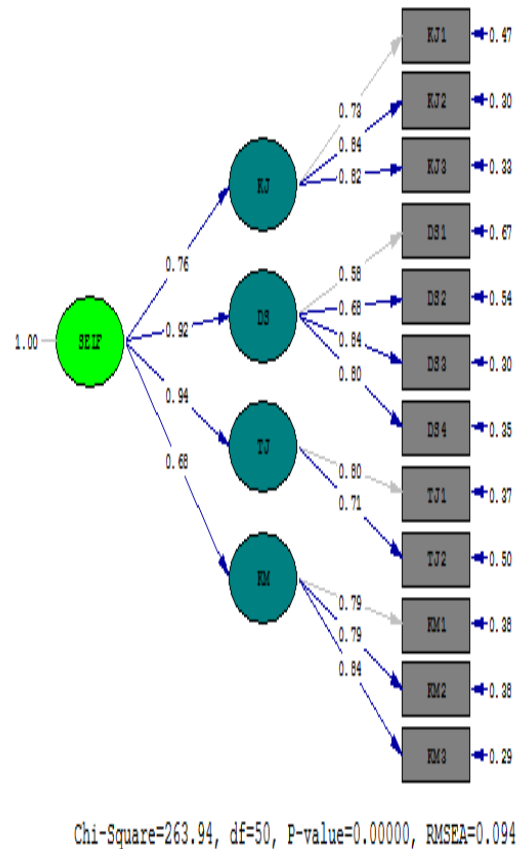

Fig. 2. CFA second-order diagram based on T-value

Fig. 1 and Fig. 2 show that the loading factor for each item > 0.5 and t-value > 1.96, means that each item contributes to the indicator. But the construct model does not meet the model's fit criteria (not fit the model). This is confirmed in table 1.

TABLE II. RESULTS OF CFA SECOND-ORDER ANALYSIS

No	Goodness of Fit	Cut of Value	Value	Decision
1	NFI	≥ 0,90	0,91	Good
2	CFI	≥ 0,90	0,93	Good
3	IFI	≥ 0,90	0,93	Good
4	RFI	≥ 0,90	0,89	not good
5	AGFI	≥ 0,90	0,87	not good

To meet the suitability of the model, modifications were made. The modified results are shown in Fig. 3 and Fig. 4

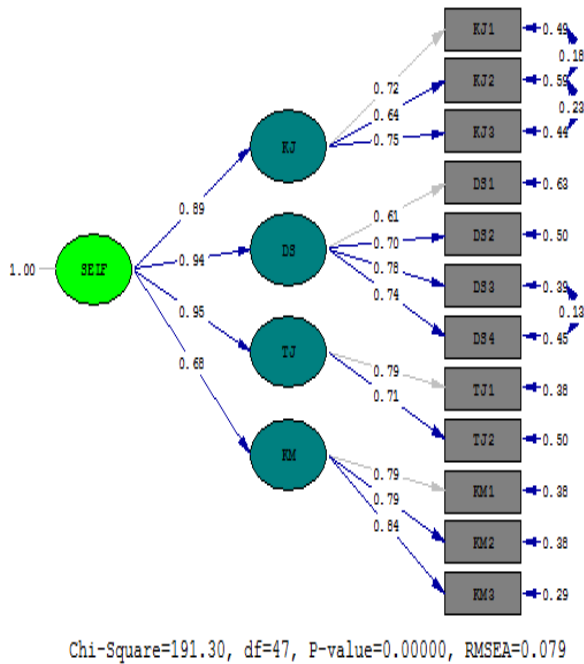

Fig. 3. CFA Second-order diagram based on standardized solution (modification)

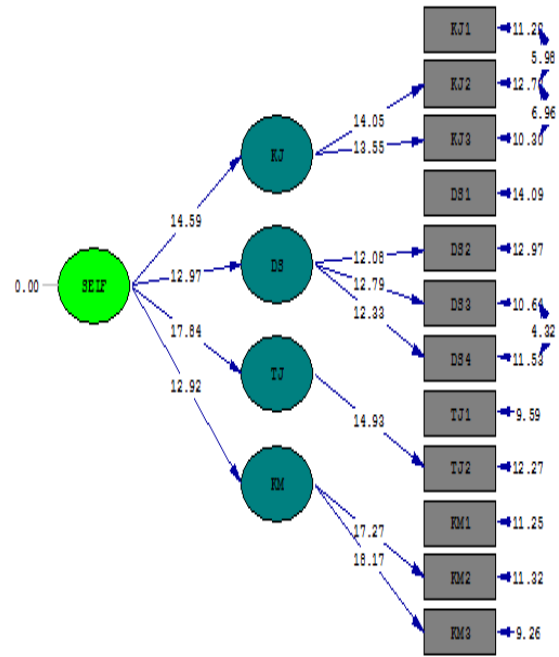

Fig. 4. CFA second-order diagram based on T-value (modification)

Based on Fig. 3 and Fig. 4 shows that factor loading for each item > 0.5 and t-value > 1.96 means that each item contributes to the indicator. It appears that the overall requirements of the goodness of fit on the type of incremental fit have been fulfilled because the values obtained are in the necessary intervals, so that the model is fit. This is confirmed in table 3.

TABLE III. RESULTS OF CFA SECOND-ORDER ANALYSIS

No	Goodness of Fit	Cut of Value	Value	Decision
1	NFI	≥ 0,90	0,94	Good
2	CFI	≥ 0,90	0,95	Good
3	IFI	≥ 0,90	0,95	Good
4	RFI	≥ 0,90	0,91	Good
5	AGFI	≥ 0,90	0,90	Good

IV. DISCUSSION

Early childhood has the potential to be developed, so that in the industrial revolution 4.0 has been introduced to technology because one of the goals of early childhood education is to develop life skills and introduce the use of various media or educational games.

Children will use various media or educational games wisely if they are supported by planting character values. One of the character dimensions emphasized is the character value of the relationship with oneself which includes; honesty, discipline, responsibility and independence. Honest is a behavior

that is based on making yourself always trustworthy in words, actions and spelling. Discipline is an action that shows the most deceptive behavior and complies with various provisions and regulations. Responsibility is the attitude and behavior of a person to carry out their duties and obligations, which must be carried out. Independent is an attitude and behavior that does not depend on others in completing tasks [11].

Based on the results of research conducted in PAUD schools the Ex Kedu Residency, it was found that the character values of relationships with oneself had developed and formed. The results of data analysis show that of the four indicators meet the criteria for loading factors. The honesty indicator (KJ) has a loading factor of 0.89, the disciplinary indicator (DS) has a loading factor of 0.94, the Indicator of responsibility (TJ) has a loading factor of 0.95, and the Indicator of independence (KM) has a loading factor of 0.68. The values of these loading factors indicate that each indicator contributes, contributes or is able to explain the character dimensions of the relationship with oneself well.

Based on the results of the above research it can be said that character education in PAUD schools in the Ex Kedu Residency embed character values in children. Based on the factor loading value of each indicator it is obtained that the responsibility indicator (TJ) has the biggest or dominant loading factor, meaning that children in PAUD schools have the power or determination of the character's value of responsibility. Responsible children are children who can exercise internal and external control [12].

Conversely the independence indicator (KM) has the smallest loading factor, so the education of the value of independence needs attention. The implementation of character education in PAUD is said to be effective if it is able to equip children with various kinds of preparation in facing the future.

Character education PAUD schools in the Ex Kedu Residency must be carried out with caution. Because early childhood is a child who is in a concrete pre-operational development stage, while character values are still abstract concepts, so an appropriate and effective method is needed to instill character values to children [13]

In order to be effective, character education can be done through three designs, namely: (1) class-based design, which is based on teacher relations as educators and children as learners, (2) school culture-based design, which seeks to build a school culture that is able to shape character children with the help of school social institutions so that certain values are formed in children, and (3) community-based designs [14].

Based on the results of this study, it was found that character education carried out was in

accordance with the objectives of character education, namely forming and building the mindset, attitudes, and behaviors of the children in order to be positive, good-spirited and responsible. In addition, the character education carried out in PAUD schools in the Ex Kedu Residency has supported the character strengthening program launched by the Government of Indonesia, in this case President Joko Widodo.

Character values that have been formed or developed especially in the dimension of character values of relationships with oneself can be used as a basis for the strength of character in the face of the industrial revolution 4.0 era in terms of the wise use of technology by young children. For example in the case of the use of mobile phones, laptop, smart phones, tablet computers, and other technologies. Continuous use of technology will cause children to become addicted. Children who are addicted usually spend most of their time playing, so children often ignore the advice or reprimands from people around. The need to instill character values and holistic and comprehensive understanding of children to be selective in usage. In addition, children must be given punishment if it is not wise or not responsible for using it.

In the context of planting the value of discipline and responsibility in the use of technology, for example, smart phones. Children are given time limits and rules for their use. The agreement and the rules made must be carried out consistently. This helps children to build a sense of responsibility and discipline.

Character education which is carried out in an integrated manner in PAUD schools, will be able to equip and instill character values to children. Character values possessed or inherent in children are expected to be the basis of strength in facing the industrial revolution 4.0.

V. CONCLUSION

Based on the results of data analysis, and the discussion can be concluded as follows.

1. Dimensions of early childhood character education in self-relations, PAUD schools in the Ex Kedu Residency consist of: honesty, discipline, responsibility, and independence. These character values can be used as a strength of character values in the industrial revolution era 4.0.
2. In addition, the character value of responsibility is the dominant factor (indicator) in the character education of early childhood in early childhood education in the Ex Kedu Residency.
3. Conversely, the value of the character of independence is a factor (indicator) is less dominant in early childhood character education in PAUD that is in the Ex Kedu Residency

REFERENCES

- [1] United Nations Industrial development organization (UNIDO). Industry 4.0: Opportunities and challenges of the new industrial revolution for developing countries and economies in transition. https://www.unido.org/sites/default/files/2017-01/Unido_industry-4_NEW_0.pdf
- [2] World Economic Forum. New vision for education report: unlocking the potential of technology. Geneva, 2015. http://www3.weforum.org/docs/WEFUSA_NewVisionforEducation_Report2015.pdf
- [3] Undang-Undang RI No. 20 Tahun 2003. Tentang Sistem Pendidikan di Indonesia, Pada pasal 28 ayat 1 berkaitan dengan Pendidikan anak usia dini, 2003.
- [4] Helmawati, "Mengenal dan memahami PAUD," PT Remaja Rosdakarya, 2015.
- [5] A. Umarov, "Early childhood care and education in South-East Asia," Buletin PADU, Ditjen Diklusepa, Edisi khusus, 2004, pp.39-44.
- [6] Sujiono dan Y. Nurani, "Konsep dasar pendidikan anak usia dini," PT indeks, 2012.
- [7] Kemendiknas, "Panduan pendidikan karakter di sekolah menengah pertama," Kementrian Pendidikan Nasional. Direktorat Pembinaan Sekolah Menengah Pertama, 2010.
- [8] Harun, "Model pendidikan karakter untuk membangun potensi harmoni sosial anak usia dini di Yogyakarta," Laporan Penelitian, 2017.
- [9] K. Schermelleh-Engel., H. Moosbrugger, and H. Mueler, "Evaluating the fit of structural equation models: Tests of significance and descriptive goodness-of-fit measures," *Methods of psychological research*, 2003, 8(2), pp.23-74.
- [10] J. F. Hair., R. E. Anderson., R. L. Tatham, and W. C. Black, "Multivariate data analysis," (4th ed.), New Jersey: Prentice Hall, 2010.
- [11] Kemendiknas, "Pengembangan pendidikan budaya dan karakter," Badan penelitian dan Pengembangan, Pusat Kurikulum, 2010.
- [12] M. Mustari, "Nilai karakter refleksi untuk pendidikan," PT Raja Grafindo persada, 2014.
- [13] A. Wibowo, "Pendidikan karakter anak usia dini," Pustaka Pelajar, 2013.
- [14] J. M. Asmani, "Buku panduan internalisasi Pendidikan karakter di sekolah," DIVA Press, 2011.