

Design Construction of Gerabah Printing Using Autodesk Inventor

Wahyudin, Wawan Purnama*

Department of Electrical Engineering Education, Faculty of
 Technology and Vocational Education
 Universitas Pendidikan Indonesia
 Bandung, Indonesia
 *wawan_purnama@upi.edu

Nabillah Agmita

Department of Physics Education, Faculty of Mathematics
 and Science Education
 Universitas Pendidikan Indonesia
 Bandung, Indonesia

Ilham Himanudin

Department of Mechanical Engineering Education, Faculty of Technology and Vocational Education
 Universitas Pendidikan Indonesia
 Bandung, Indonesia

Abstract—Gerabah Printing is an automatic pottery making tool based on CNC. This technology is used to create the initial shape of pottery according to the virtual design that has been created. The purpose of this research is to design the concept of Gerabah Printing mechanical system that can later be used as a reference in making Gerabah Printing machine in real time. To obtain the results of Gerabah Printing mechanical system concept design, conducted field survey stage, literature study, designing solutions in the form of Gerabah Printing, composing Gerabah Printing concept, and design 3 dimensional Gerabah Printing using Autodesk Inventor software. Finally, created a 3D design from Gerabah Printing and the concept of its work. The main components of Gerabah Printing are automatic rotary table, forming arms, water sprayer, frame and hardware box. That design based on machine technology which is studied by many young people and it's made in based on principle of ergonomic work tools so that can reduce the risk of musculoskeletal in pottery craftsman and can attract the younger generation to become pottery craftsmen.

Keywords—*gerabah printing, musculoskeletal, 3D models, pottery*

I. INTRODUCTION

Indonesia is a country with various ethnicities, cultures and arts. One of the arts found in Indonesia is pottery art. Pottery is an identical handicraft made of clay, pottery has existed since the time of experts (metal age) until now. Pottery is commonly used as kitchen utensils such as glasses, plates, jugs and decorations. Pottery crafts are scattered throughout Indonesia, namely in Banten, Cirebon, Purwakarta, Jepara, Yogyakarta, and other areas [1]. The process of making pottery starts from the preparation stage, the pottery forming stage, the drying stage, the burning stage, and the finishing stage (decoration and coloring). The four stages take quite a long time, which is

approximately one week. The stage that is quite difficult is the drying stage of the pottery because it depends on the weather and the stage of forming the pot because it requires experts or is used to making pottery. Today, people who want to become pottery craftsmen are very rare, because very few young people want to become pottery craftsmen [2]. Currently, the descendants of pottery craftsmen in various regions do not want to continue the work of their parents as pottery craftsmen and choose other jobs [3,4]. This resulted in the pottery craftsmen becoming parents. On the other hand, old pottery craftsmen have a higher risk of developing musculoskeletal complaints [5-7]. Musculoskeletal is a complaint in the skeletal muscles due to continuous activity, static body position and for a long time [6]. In the process of making pottery, the process of forming pottery is the cause of musculoskeletal complaints [8]. When the process of forming pottery using a conventional spindle (rotary table) requires the pottery craftsman to work in a bad work position (not ergonomic), namely sitting with bent legs, bending the body and bending the neck for hours, causing musculoskeletal complaints on the bottom back [5].

Technology is needed to overcome the difficult problem of regenerating pottery craftsmen and musculoskeletal complaints for pottery craftsmen. Currently the technology contained in the pottery formation process in Indonesia is an ergonomic pottery machine, this ergonomic machine is in the form of an automatic spindle driven by an electric motor that acts as a substitute for the leg as a conventional spindle drive and after being implemented this machine is able to reduce the musculoskeletal complaint rate by 18, 76% [9]. However, this ergonomic machine has not been able to solve the difficult problem of regenerating pottery craftsmen because it still requires pottery craftsmen who have special skills, most of whom are now elderly. In today's digital era, many large-scale industrial machines have implemented automation systems and

one of the automation machines that are often used is CNC or Computer Numerical Control. The main workflow of CNC is drawing, then programming, then entering the program, and the manufacturing process runs automatically [10]. Machines that have implemented CNC include drilling machines, milling machines, 3D printing machines, bending machines and milling machines. The advantages of CNC machines are high machine accuracy, high productivity, and can minimize human error [11].

With the existence of CNC technology that can facilitate and increase productivity and minimize human error, the authors review that CNC technology is a modern technology and is widely studied by students and mechanical engineering students so that it can attract the younger generation to become pottery craftsmen and overcome the difficult problem of regenerating pottery craftsmen. Therefore, the authors are interested in making Gerabah Printing: Automatic Computer for Numerical Control-Based Pottery Maker. Pottery Printing is an automatic pottery maker or maker which in principle is similar to the manual pottery forming process, namely using a rotary table and using an arm to form clay. Gerabah Printing serves to make the initial form of pottery using a virtual design from a computer. The virtual design is converted into G-code. Then the Arduino will run the G-code function on the stepper motor and servo motor drives. The following is an overview of the product results that will be made by Gerabah Printing.



Source: www.bentarabudaya.com

Fig. 1. Initial description of the pottery that will be made by Gerabah Printing.

After the initial shape of the pottery made by Gerabah Printing is complete, drying and finishing is carried out by the craftsmen such as making accessories and coloring. This is done so that the art value of pottery made by pottery craftsmen is maintained.

From the background description above, the problem formulation that must be resolved is how the Gerabah Printing concept can overcome the difficult problem of regenerating pottery craftsmen and can reduce the risk of musculoskeletal complaints on pottery craftsmen. The purpose of this study was to determine how the design and workings of Gerabah Printing.

II. METHODS

The method used in the implementation of this article is the design and development method (Design and Development / DnD). The DnD method is a way of creating procedures, techniques, and / or tools based on methodical analysis of

specific cases [12]. The procedure for implementing this research is shown in Figure 2.

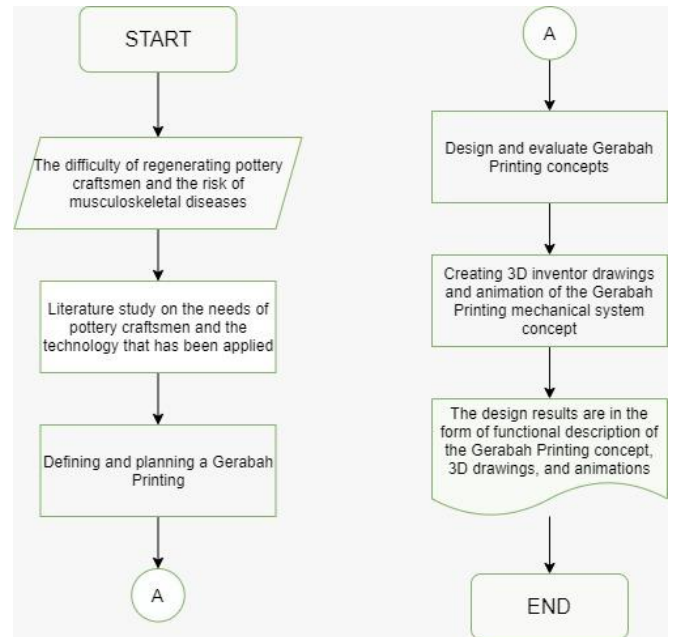

Fig. 2. Flowchart of procedure.

From the diagram image above, it can be detailed as follows:

A. Identification of Problems

Problem identification is an activity to find problems that can be solved and are in the surrounding environment. Researchers conducted a survey on pottery craftsmen in Purwakarta. There the researcher found a problem that was immediately expressed by the pottery craftsmen, namely the difficulty of regenerating pottery craftsmen.

B. Study of Literature

Literature study contains a series of activities to find and review relevant and reliable literature related to the problems found. The literature we use comes from books, journals, news, and websites. Researchers sought additional information regarding the difficulty of regenerating pottery craftsmen and found a link between the difficulty of regenerating pottery craftsmen which resulted in only elderly pottery craftsmen and elderly pottery craftsmen at risk of developing complaints of musculoskeletal disease. In addition, we also studied pottery manufacturing technology and studied Computer Numerical Control (CNC) machine theory.

C. Design and Development

The design and development process includes defining the solution (Gerabah Printing) for the problem found. Then, design and design the Gerabah Printing model using Autodesk Inventor software. Furthermore, it was developed by making an animated video on how Gerabah Printing works.

D. Validation and Evaluation

After the design is made, the Gerabah Printing design is validated by engineers and various inputs are obtained to evaluate and improve the design.

III. RESULTS AND DISCUSSION

After identifying the problem and studying the literature, it is followed by a design and development phase accompanied

by validation and evaluation. In the Gerabah Printing design process, initially the main components of Gerabah Printing were the frame, rotary table, forming arms, and water sprayer. However, the design was evaluated and received input to add a drainage component to keep the clay from drying out. So that the final design shown by figure 3 and table 1.

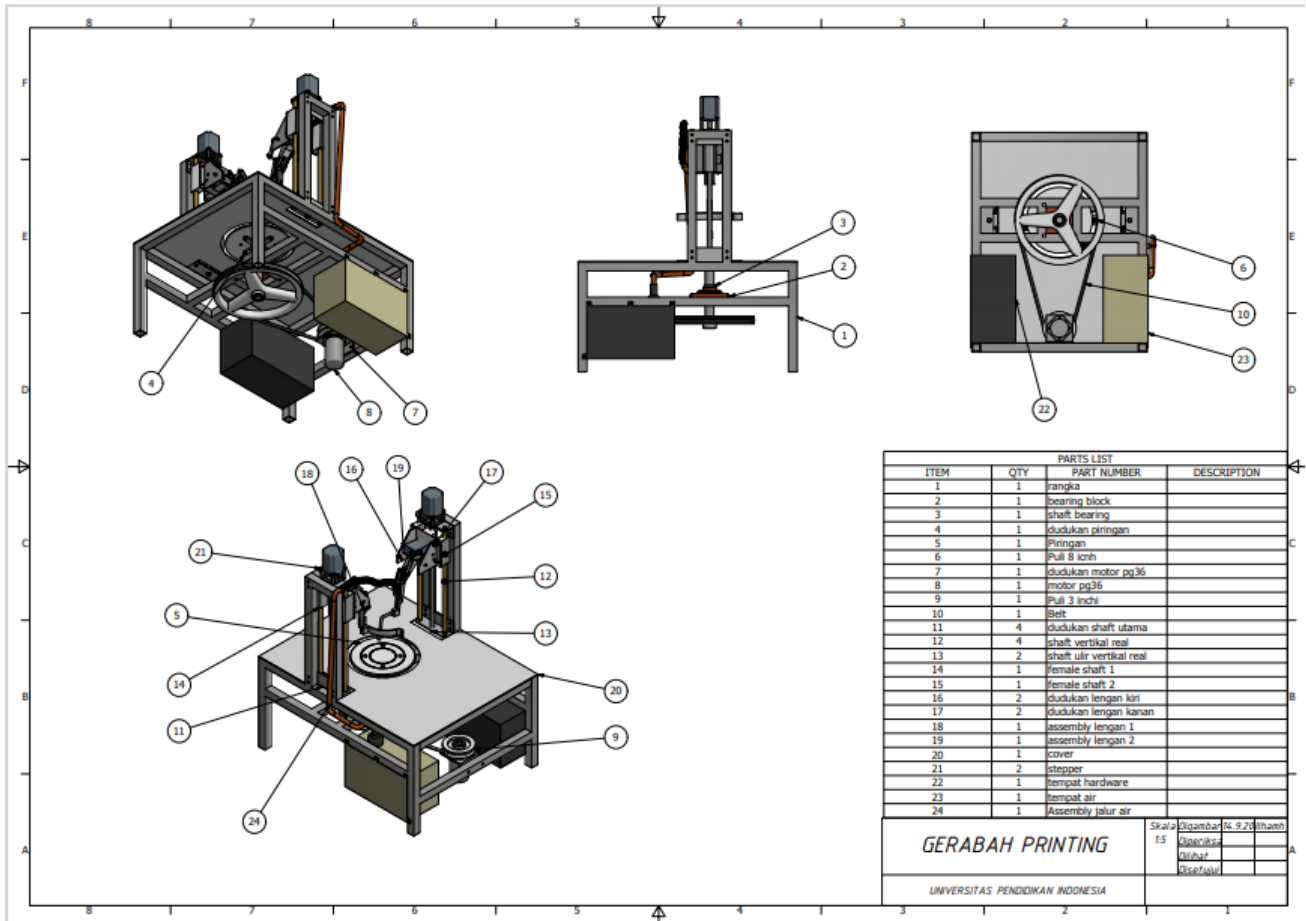

Fig. 3. Mechanical design of gerabah printing.

TABLE I. PART LIST OF GERABAH PRINTING

Item Number	Qty	Item Name
1	1	Frame
2	1	Bearing block
3	1	Shaft (pulley)
4	1	Turntable holder
5	1	Turntable
6	1	Pulley 8"
7	1	Bracket dc motor pg36
8	1	Dc motor pg36
9	1	Pulley 3"
10	1	Belt
11	4	Bracket shaft
12	4	Vertical shaft

Table 1. Cont.

13	2	Vertical thread shaft
14	1	Nut 1
15	1	Nut 2
16	2	Bracket arm 1
17	2	Bracket arm 2
18	1	Assembly arm 1
19	1	Assembly arm 2
20	1	Cover
21	2	Stepper
22	1	Hardware box
23	1	Water container
24	1	Assembly of waterway (water sprayer)

The hardware work system of Gerabah Printing is described as follows:

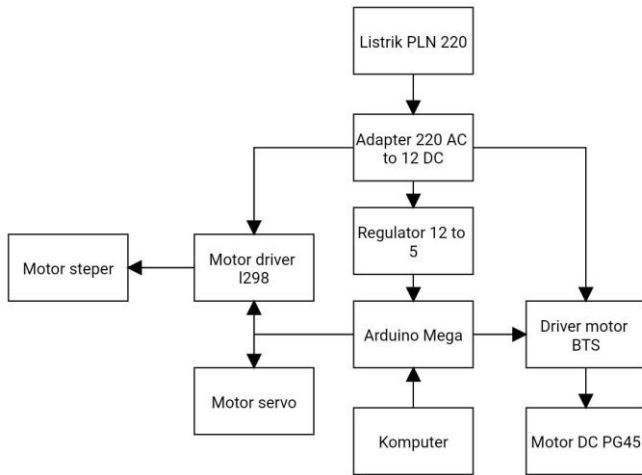

Fig. 4. Block diagram of hardware work from gerabah printing.

- PLN electricity voltage of 220 volts enters the adapter 220 volt AC to 12 volt DC and then supplies electricity to the driver motor and regulator, as the motor and Arduino are ready to work
- Clay stored on a rotary table controlled by PG36 motor
- Pottery design in input through computer and Arduino ordered Gerabah Printing system to form pottery
- Stepper motor and servo motor work to move the forming arm
- The shaper ladder forms a clay that rotates on a turntable (disc)
- Pottery crafts have been formed

The combination of mechanical design and hardware work systems can define the general way of working of Gerabah Printing, which is as follows:

- The first stage is designing the pottery model to be made. Designs can be made using 3-dimensional design software found on computers such as Aspire, Autodesk Inventor, TinkerCAD, SketchUp, etc. ...
- Then, the design that has been made is then converted into the G programming language, until the G code or G-code is obtained.
- G-code entered into Gerabah Printing via the available USB port.
- The G-code that has been received will then be processed by the Arduino microcontroller, Arduino will instruct the Pg36 motor to rotate the dish on which clay is already contained.

- Then Arduino will order the stepper motor and servo motor so that the forming arm works to form the pottery according to the design that has been made.
- The initial shape of the earthenware has been formed and is ready to enter the drying, burning, decking, and coloring stages.

Because of the character of millennials who are easily familiar with technology, Gerabah Printing design that has been made using Computer Numerical Control which is much studied by mechanical engineering student today. All of Gerabah Printing designs that have been created based on the principle of an ergonomic tool that does not leave the operator in a static state for too long. Gerabah Printings do not demand that their operators continue to stand or continue to sit because Gerabah Printing operators are only required to control occasionally. Hopefully Gerabah Printing design when realized can reduce musculoskeletal complaints for pottery craftsman and can attract the interest of the millennial generation to become pottery craftsmen.

IV. CONCLUSION

Gerabah Printing is a computer numerical control (CNC) based automatic pottery maker. The main components of the Gerabah Printing are a frame, a rotary table known by the Pg36 motor, a forming arm controlled by a servo motor and stepper motor, and a water channel. The way Gerabah Printing works in general is begins with the process of making 3-dimensional designs of pottery, the design coding process, and the process of forming pottery by Gerabah Printing. With the Gerabah Printing that has integrated technology into the franchise production system, it is hoped that it will attract the interest of the millennial generation to become pottery craftsmen.

ACKNOWLEDGMENT

The researchers would like to thank the PKM Center FPTK UPI, Belmawa UPI, UPI internal reviewers, and the Ministry of Education and Culture who have supported us both technically and financially.

REFERENCES

- [1] M.R. Kusnan, *Aneka Gerabah*. Saka Mitra Kompetensi. Klaten, 2007.
- [2] Asnan, "Perajin Gerabah Semakin Langka. Radar Bojonegoro," [online]. Retrieved from <https://radarbojonegoro.jawapos.com/read/2018/03/24/59444/perajin-gerabah-semakin-langka>, accessed on September, 5, 2020.
- [3] Nafsiani, "Kerajinan gerabah di Umbul Gentong," [online]. Retrieved from <https://kerajinanindonesia.id/kerajinan-gerabah-di-umbul-gentong/>, accessed on 5 September 2020.
- [4] H.A.S. Putra and M. Arif, "Gerabah Di Kelurahan Karang Tuban Tergerus Oleh Budaya Global," *Jurnal Seni Rupa*, vol. 8, no. 3, 2020.
- [5] S. Syarlina, "Faktor-Faktor Yang Berhubungan Dengan Keluhan Nyeri Punggung Bawah Pada Pengrajin Gerabah Di Lingkungan Sandi Kelurahan Pallantikang Kecamatan Pattallassang Kabupaten Takalar,"

- Sulolipu: Media Komunikasi Sivitas Akademika dan Masyarakat, vol. 19, no. 1, pp.7-14, 2019.
- [6] S.G.P. Kattang, P.A. Kawatu, and A.A. Tucunan, "Hubungan Antara Masa Kerja Dan Beban Kerja Dengan Keluhan Muskuloskeletal Pada Pengrajin Gerabah Di Desa Pulutan Kecamatan Remboken Kabupaten Minahasa," *Kesmas*, vol. 7, no. 4, 2018.
- [7] S. Mindayani, "Perbaikan Fasilitas Kerja Untuk Mengurangi Keluhan Muskuloskeletal," *Jurnal Endurance*, vol. 3, no. 2, p. 313, 2018.
- [8] Y.K. Kairupan, L.F. Suoth, and F.K. Kolibu, "Hubungan Antara Sikap Kerja Dan Indeks Massa Tubuh Dengan Keluhan Nyeri Punggung Pada Pekerja Pembuat Gerabah Di Desa Pulutan Kecamatan Remboken," *Kesmas*, vol. 7, no. 4, 2018.
- [9] I.K. Widana, N.W. Sumetri, and I.N. Budiartana, "Implementasi Mesin Gerabah Ergonomis Mengurangi Sakit Akibat Kerja," *Prosiding SNITT POLTEKBA*, vol. 3, no. 1, pp. 72-78, 2018.
- [10] Testindo, "Penjelasan seputar mesin CNC," [online]. Retrieved from <http://www.testindo.com/article/429/penjelasan-seputar-mesin-cnc>.
- [11] R.C. Richey and J.D. Klein, *Design and Development Research*. London: Lawrence Erlbaum Associates, Inc., 2007.