

# Breast Care With Rotating Pressure to Facilitate Breastmilk Based on ATMEGA328

Erika Loniza<sup>1\*</sup>, Andriyani<sup>1</sup> Muhammad Irfan<sup>2</sup>

<sup>1</sup> *Department of Medical Electronics Technology, Universitas Muhammadiyah Yogyakarta, Indonesia*

<sup>2</sup> *PKU.Muhammadiyah Gamping Hospital, Yogyakarta, Indonesia*

\*Corresponding author Email [erika@umy.ac.id](mailto:erika@umy.ac.id)

## ABSTRACT

Breast milk is the perfect food for babies in early life because it contains many antibodies for the baby's immunity and can prevent diarrhea that will cause infants' and toddlers' death. Many *postpartum mothers* complain that their milk does not come out, so that they cannot provide adequate milk coverage to their babies and experience breast engorgement because the milk collects in the ductal system causing breast pain and soreness. Two hormones are essential in influencing breast milk, namely the hormone prolactin and the hormone oxytocin. It is necessary to stimulate those hormones by oxytocin massage and *breast care*. This study aimed to design a BERES therapy instrument equipped with warm compresses to facilitate breastmilk. This study compared before and after therapy in *postpartum* mothers with ten respondents. This study exposed an increase in ml, with an average increase of 27,3 ml, while the average breastmilk volume before treatment was 20 ml. The increase in breast milk volume shows that this therapeutic instrument works as expected. The results of the instrument function test with a 15-minutes timer measurement obtained an average of 900 seconds and a 20-minutes timer measurement an average of 1199 seconds; it means that the time *setting* is accurate, and the temperature measurement on a warm compress is stable with a temperature range of 40 ° C - 44 ° C, so it is safe and comfortable to use for postpartum mothers

*Keywords—Breast milk, Breast Care, Rotating Pressure*

## 1. INTRODUCTION

Breast milk (Breast Milk) is the perfect food for babies because breast milk composition suitable for the baby's needs, and the content of the most protective substances is in the colostrum. Colostrum is yellowish breast milk produced the first three days after the baby is born. Breast milk is the first immunization given to babies because breast milk contains various immune and immunoglobulin substances that make breast milk irreplaceable from formula milk. Exclusive breast milk is another no-food supplement in infants aged 0-6 months[1][2][3]. So great are the benefits of breast milk that it is recommended for a mother to breastfeed her child for two years, Allah SWT said in Q.S. Al Baqarah 2 verse 233, which means "Mothers should breastfeed their children for two whole years."

The number of nursing mothers is only 42% of all mothers who give birth; of that 42%, only 44% of babies get breast milk the first hour after birth. Then 62% of babies got breast milk on the first day after birth, and 50,8 of babies were given breast milk within the first one month of birth. Breast Milk Coverage in Indonesia in 2011 was 17%, and in 2012 it was 27%. Despite the increase, the coverage of exclusive breastfeeding did not meet the target in 2012. The data is taken from The Indonesian Demographic and Health Survey (SDKI) data in 2012 [4][5][6]. Based on government

regulation of the Republic of Indonesia number 33 of 2012, breast milk must be given to infants from birth during the first six months without adding or replacing other food or beverages [7][8]. The national target in exclusive breastfeeding is 80%; however, based on Basic Health Research (Riskesdas), exclusive breastfeeding in infants for six months is only 40,6%, far from the target set. The less exclusive breastfeeding to the baby from the mother leads to indigestion, lack of immunity, and respiratory tract infections in the baby. Deficiency in breast milk production and poor knowledge of breastmilk's importance are the causes of mothers' decision to give formula milk to their babies. The World Health Organization (WHO) reports the cause of the high infant mortality rate (IMR) 55% of cases suffered acute pneumonia, and 55% of deaths due to diarrhea by underprivileged food in the first six months of life [9][10][11].

In increasing the coverage of exclusive low breastfeeding rates, there needs to be an effort to increase breastfeeding. In this effort, two crucial things affect the production and expenditure of breast milk[12]. The hormone prolactin influences breast milk production while breast milk production is affected by the hormone Oxytocin. Prolactin and oxytocin hormones can affect breast milk production, so it must perform breast care by breast care method and massage in the spinal area. By stimuli in the hormones

prolactin and Oxytocin can increase the production of breast milk [13][14].

Breast care postpartum is a necessity for mothers. Wherewith breast care will significantly help the production of breast milk that impacts increasing breast milk production. If a mother is stimuli in manual breast care, it will routinely help increase breast milk production so that the mother can breastfeed exclusively [15][16].

Warm compresses are an option to reduce and even overcome pain in the breast. Pain in the breast is a problem in postpartum mothers that arises from milk infusion or breast engorgement due to narrowing the lactiferous ducts that are not completely emptied [17]. Breast milk dam will cause breast pain, heat, pain, and tension, making postpartum mothers uncomfortable and can inhibit milk production due to these conditions [18][19]

Another method to increase milk production is by taking the domperidone. Generally, this medication is consumed at a dose of 30-60 mg/day, and the maximum recommended dose is 80 mg/day. After 14 days at a dose of 30 mg/day, the use of domperidone increased breast milk volume by 215%. If consumed at a 60 mg/day dose, it could increase breast milk by 367%, but increasing the dose of domperidone was directly proportional to the side effects. The side effects of taking 30 mg/day are headaches, dry mouth, and stomach cramps; then, if taking 60 mg/day, there are additional side effects such as constipation and depression. The effect on infants is not significant because the amount of domperidone secreted in breast milk is 0,2 µg / kg/day[20]. The domperidone dose must be gradually decreased to discontinue the usage since it can trigger withdrawal symptoms, including anxiety, insomnia, and an increase in pulse [21][22][23].

From the existing problems, by today's rapidly developing technological advances, there should be no such problems mentioned earlier; therefore, breastfeeding mothers need an instrument that works automatically to help their work without giving side effects to postpartum mothers themselves. Therefore, the researcher wanted to design a tool in the form of an automatic mammary gland massage bra using the Arduino-based breast care method to facilitate breastmilk and is equipped with a warm compress to relieve breast pain, causing a relaxing effect on the user.

## 2. RESEARCH METHODS

### 2.1. Software Design

Based on the tool's design, it is found that the various flow in **Figure 1** is a massage tool flow chart, and **Figure 2** is a flow chart on the compress tool used in prototype work.

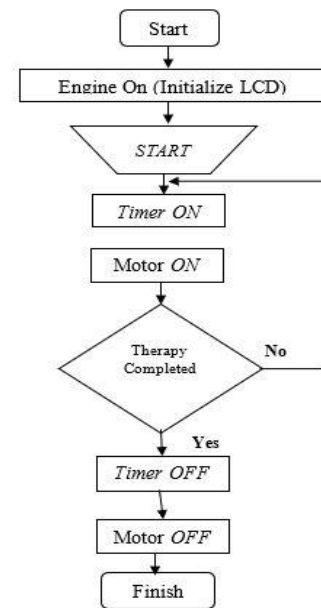

**Figure 1.** Massage Tool Flowchart

When the switch is in the ON position the microcontroller initializes the program to run, after pressing the start button, the motor will move as a massage control and the duration of the tarapi lasts according to the time set. After the therapy has been carried out, the motor will stop moving according to the time setting that was set at the beginning, if the therapy fails or has not been completed, the process will repeat from the start process. After the motor stops, the massage therapy process is complete.

When the appliance is turned on, the heater will run, then press the start button; the timer will count down for 15 minutes. After the time has reached 15 minutes, the heater will die; if the therapy fails or has not been completed, it will repeat from the ON timer process. After the heater turns off, the therapy process is complete.

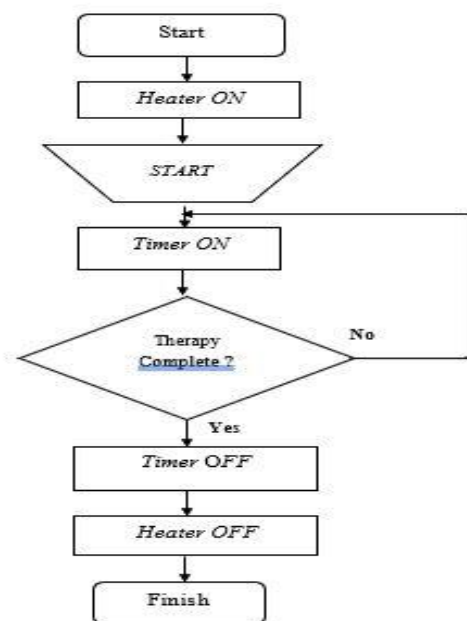

**Figure 2** Compress Tool Flow Chart

## 2.2. Hardware Design

### 2.2.1. Minimum System Circuit

The component specifications used in the minimum circuit of this microcontroller system use ATmega328P, 16MHz crystal, push-button, 330Ω, and 10kΩ resistors, LEDs, and 10μF and 22pF capacitors. This circuit requires a voltage of + 5VDC and GND to work. Serves as a tool activity controller where the ATmega328P IC is given a program to control the tool's overall work system. This system's minimum circuit is equipped with I2C, which connects the LCD as a time display with a microcontroller [24].

### 2.2.2. Motor Driver Circuit

The component specifications used in this motor driver circuit are BD139, transistor, 330Ω resistor, and 12V relay [25]. The circuit is as presented in Figure 3.

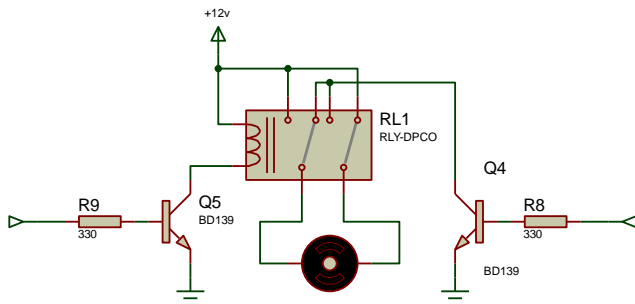

Figure 3. Motor Driver Circuit

In this circuit, two transistors function as switches. The transistor Q4 functions to switch the motor grounding so that when it is given HIGH logic on the input, the collector and emitter legs are connected, and the motor will rotate. Transistor Q5 functions to switch the relay's grounding so that when given HIGH logic input, the relay will be active; the relay's function is to change the motor's polarity. The motor rotation will automatically change when the relay is activated, and the motor rotation will return to its original state when the relay is turned off again.

### 2.2.3. Driver Heater Circuit

The component specifications used in this heater driver circuit are BD139, transistor, 330Ω resistor, solid-state relay (SSR), and A.C. heater. The heater driver circuit functions to control the heater's work, where the heater is turned on using the voltage from the PLN networks.

## 2.3. Data Collection

Data collection is by measuring milk volume in breastfeeding mothers by comparing the volume of breast milk before and after using the therapeutic tool. Measure heater temperature using a digital thermometer. Measure the punctuality of setting using a stopwatch and count the number of massager revolutions against time.

## 2.4. Instrument Design

The prototype massager has a keypad that functions as a start button, a 15-minute timer, a 20-minute timer, and reset, and uses a 16 × 4 LCD to display the time. There is a LAN cable as a link between the control box and the therapy vest.

Figure 4 is a compress tool design that has been created.



Figure 4. Compress Tool Design

In the compress prototype are two push buttons to start and reset, an on / off switch to turn on and off the therapy device's control.

## 3. RESULT AND DISCUSSION

### 3.1. Breastmilk Total Volume Measurement

This test is performed on postpartum mothers with an age range of 21-33 years; the measurement is proceeded by comparing the volume of breast milk before and after using the therapeutic device; the measurement results are presented in Table 1.

Table 1. Breastmilk Total Volume Measurement

No.	Name	Result Data (ml)	
		Before	After
1	Sumarsini	30	42
2	Wulan	2	10
3	Purwani	20	28
4	Tri	5	10
5	Arum	45	70
6	Astuti	10	8
7	Rima	20	28
8	Diani	18	18
9	Ifah	35	39
10	Itun	15	20
<b>Total</b>		<b>200</b>	<b>273</b>
<b>Mean</b>		<b>20</b>	<b>27.3</b>

Table 1 shows the results of measurements of the amount of breast milk volume carried out by respondent ten postpartum mothers; before doing therapy, the average

amount of breast milk was 20 ml, and after therapy had increased by an average amount of 27,3 ml.

**3.2. Timer Measurement**

The measurement test is done by measuring the timer ten times on a therapeutic device using a stopwatch. Measurement of the timer was carried out at the respective setting times on the appliance, namely 15 minutes and 20 minutes [17]. The measurement results are in **Table 2**.

**Table 2.** Measuring *timer* on the massager

Timer (seconds)	Total	Mean	Error
900	9000	900	0%
1200	11990	1199	0,08%

Table 2 shows the measurement results of the 15 minute and 20-minute timers. The obtained percentage error in the measurement of the 15-minute timer is 0%, and the percentage of error in the measurement of the 20-minute timer is 0,08% with 1 correction value.

**3.3. Massage Cycles Total to Time**

This test is undergone by computing the number of massager rotations for ten trials; the data are in **Table 3**.

**Table 3.** Massager Cycles Total to Time

Minutes Number	Number of Left rotation	Number of Right rotation
1	8	9
3	24	27
5	40	45
7	56	63
9	72	81
11	88	99
13	104	117
15	120	135
17	136	153
19	152	171
<b>Total</b>	800	900
<b>Mean</b>	8	9

In **Table 3**, it is revealed that the average rotation on the left side is eight times, and the average rotation of the right side is nine times; this number has a rotation tolerance on the tool as much as one time.

**3.3. Compress Tool Temperature Measurement**

The temperature measurement test on the compress measures the temperature using a digital thermometer every minute for 15 minutes to determine whether the temperature is stable or not, where the temperature is safe for warm compresses with a value range of 40,5 ° C - 45 ° C [5]. The results of temperature measurements on the compress are in **Table 4**.

**Table 4.** Compress Tool Temperature Measurement

No.	Minutes Number	Heater Temperature Left Side	Heater Temperature Right Side
1	1	42,7°C	41,5°C
2	2	42,1°C	41,2°C
3	3	41,8°C	41,3°C
4	4	41,8°C	41,8°C
5	5	41,7°C	41,8°C
6	6	42,1°C	41,7°C
7	7	41,9°C	41,5°C
8	8	41,9°C	41,9°C
9	9	41,7°C	41,4°C
10	10	42,6°C	41,6°C
11	11	42,2°C	42°C
12	12	42,2°C	42,1°C
13	13	43,2°C	42,3°C
14	14	42,7°C	41,7°C
15	15	42,4°C	42,9°C

In **Table 4**, the right and left heaters to have temperatures between 41,2 - 43,2 ° C, so it is safe and comfortable to use for postpartum mothers because they do not exceed the recommended compress temperature.

**4. CONCLUSIONS**

After carrying out the manufacturing process, experiments, testing tools, and data collection, it can be concluded as follows:

1. In the average measurement, breast milk has increased after therapy by 27, 3 ml.
2. In the timer measurement with a stopwatch as comparing instrument, the error value is 0% for the 15-minute timer data collection, while the 20-minute timer data collection

with a correction value for 1 second and an error value of 0,08%.

3. In measuring the number of rotations of the massager against time, it has an average value of 8 turns on the left and has an average value of 9 turns, where this number has a correction of 1 turn due to different gear conditions.
4. In measuring the compress's temperature on the heater on the right and the left is stable, where the safe temperature range for warm compresses is 40 °C - 45 °C, so it is safe and comfortable when used for postpartum mothers.

## ACKNOWLEDGMENTS

This research was fully supported by the University of Muhammadiyah Yogyakarta and the Department of Electro-Medical Technology.

## REFERENCES

- [1] J. K. Luter, "Perbedaan Pemberian Asi Eksklusif Dan Asi Non Eksklusif Dengan Perubahan Berat Badan Pada Bayi Di Puskesmas Bahu Manado," Vol. 4, Pp. 4–9, 2016.
- [2] G. Unit, P. Mary, And M. Hospital, "Biochem. 12 (1975) 48 Y-Glutamyltransferase In Breast Milk," Vol. 12, Pp. 48–50, 1975.
- [3] S. Larson, S. Yang, A. Chacko-Stacey, D. Mason, And E. Hart, "Self-Resolving Vulvar Breast Tissue Arising In The Post-Partum Setting: A Case Report And Review Of Literature," J. Hum. Lact., Vol. 36, No. 2, Pp. 348–351, 2020.
- [4] T. A. Susilani And H. Kurniawan, "Pemberian Jintan Hitam (Nigella Sativa) Dalam Peningkatan Kadar Hormon Produksi Asi (Prolaktin Dan Oksitisin ) Serta Jumlah Neutrofil Neonatus Dari Ibu Post Seksio Sesarea Di Yogyakarta," Permata Indones., Vol. 7, No. 2086–9185, Pp. 1–14, 2016.
- [5] L. R. Mitoulas, C. T. Lai, L. C. Gurrin, M. Larsson, And P. E. Hartmann, "Efficacy Of Breast Milk Expression Using An Electric Breast Pump," J. Hum. Lact., Vol. 18, No. 4, Pp. 344–352, 2002.
- [6] M. Héon, C. Goulet, C. Garofalo, A. M. Nuyt, And E. Levy, "An Intervention To Promote Breast Milk Production In Mothers Of Preterm Infants," West. J. Nurs. Res., Vol. 38, No. 5, Pp. 529–552, 2014.
- [7] R. Indonesia, "Peraturan Pemerintah No.33 Tahun 2012 Tentang Pemberian Air Susu Ibu Eksklusif." Sekretariat Negara, Jakarta, 2012.
- [8] P. Sisk, S. Quandt, N. Parson, And J. Tucker, "Breast Milk Expression And Maintenance In Mothers Of Very Low Birth Weight Infants: Supports And Barriers," J. Hum. Lact., Vol. 26, No. 4, Pp. 368–375, 2010.
- [9] F. Ummah, "Pijat Oksitosin Untuk Mempercepat Pengeluaran Asi Pada Ibu Pasca Salin Normal Di Dusun Sono Desa Ketanen Kecamatan Panceng Gresik," Exp. Cell Res., Vol. 02, No. 1, Pp. 121–125, 2014.
- [10] K. Septiani Hanulan, Budi Artha, "Faktor-Faktor Yang Berhubungan Dengan Pemberian Asi Eksklusif Oleh Ibu Menyusui Yang Bekerja Sebagai Tenaga Kesehatan," J. Ilmu Kesehat., Vol. 59, No. 3, Pp. 555–557, 2017.
- [11] S. A. Keim, J. L. Daniels, A. M. Siega-Riz, N. Dole, A. H. Herring, And P. C. Scheidt, "Depressive Symptoms During Pregnancy And The Concentration Of Fatty Acids In Breast Milk," J. Hum. Lact., Vol. 28, No. 2, Pp. 189–195, 2012.
- [12] P. D. Hill Et Al., "Association Of Serum Prolactin And Oxytocin With Milk Production In Mothers Of Preterm And Term Infants," Biol. Res. Nurs., Vol. 10, No. 4, Pp. 340–349, 2009.
- [13] T. Wijayanti And A. Setyoningsih, "Perbedaan Metode Pijat Oksitosin Dan Breast Care Dalam Meningkatkan Produksi Asi Pada Ibu Post Partum," J. Komun. Kesehat., Vol. 8, No. 2, Pp. 1–12, 2017.
- [14] K. E. Hays Et Al., "Duration Of Cisplatin Excretion In Breast Milk," J. Hum. Lact., Vol. 29, No. 4, Pp. 469–472, 2013.
- [15] T. Wijayanti And A. Setyaningsih, "Jurnal Kebidanan Efektifitas Breast Care Post Partum Terhadap Produksi Postpartum Breastcare Effectiveness Of Production Asi," J. Kebidanan, Vol. Viii, No. 02, Pp. 201–208, 2016.
- [16] M. Bolman, L. Saju, K. Oganessian, T. Kondrashova, And A. M. Witt, "Recapturing The Art Of Therapeutic Breast Massage During Breastfeeding," J. Hum. Lact., Vol. 29, No. 3, Pp. 328–331, 2013.
- [17] A. M. Witt, M. Bolman, S. Kredit, and A. Vanic, "Therapeutic Breast Massage in Lactation for the Management of Engorgement, Plugged Ducts, and Mastitis," J. Hum. Lact., vol. 32, no. 1, pp. 123–131, 2016.
- [18] N. Runiari and Surinati, "pengaruh pemberian kompres panas terhadap intensitas nyeri pembengkakan payudara pada ibu post partum di wilayah kerja puskesmas pembantu dauh puri," 2012.
- [19] E. Kernerman and E. Park, "Severe breast pain resolved with pectoral muscle massage," J. Hum. Lact., vol. 30, no. 3, pp. 287–291, 2014.
- [20] P. A. Ulutas and A. Ozpinar, "Effect of Mannheimia (Pasteurella) haemolytica infection on acute-phase proteins and some mineral levels in colostrum-breast milk-fed or colostrum-breast milk-deprived sheep," Vet. Res. Commun., vol. 30, no. 5, pp. 485–495, 2006.
- [21] W. Vincencius and C. Michael, "Domperidone untuk Meningkatkan Produksi Air Susu Ibu ( ASI )," vol. 43, no. 3, pp. 225–228, 2016.
- [22] H. E. Rowe, K. Felkins, S. D. Cooper, and T. W. Hale, "Transfer of linezolid into breast milk," J. Hum. Lact., vol. 30, no. 4, pp. 410–412, 2014.
- [23] Y. Tateoka, "Bisphenol A concentration in breast milk following consumption of a canned coffee drink," J. Hum. Lact., vol. 31, no. 3, pp. 474–478, 2015.
- [24] N. Mdpo, "National mdpo," 1965.
- [25] I. Smolyanov, E. Shmakov, and D. Gasheva, "Research of Linear Induction Motor as Part of Driver by Detailed Equivalent Circuit," Proc. - 2019 Int. Russ. Autom. Conf. RusAutoCon 2019, 2019.