

The Mediating Effect of Enterprise Risk Management on the Determinant Factors of Firm Value

Hernawati Dewi¹, Deni Iskandar^{2*}, Rudolf Lumbantobing²

¹*Master of Management, Krida Wacana Christian University, Indonesia*

²*Faculty of Economics and Business, Krida Wacana Christian University, Indonesia*

**Corresponding author. Email: denny.iskandar@ukrida.ac.id*

ABSTRACT

This research aimed to analyze the mediating effect of Enterprise Risk Management (ERM) in the effects of managerial ownership, profitability, leverage, and firm size toward firm value. The results indicate that managerial ownership, profitability, and firm size significantly and positively affect firm value. On the other hand, leverage and ERM do not significantly affect firm value. Managerial ownership, profitability, and leverage have no significant effect on ERM, but firm size significantly and positively affect ERM. However, ERM does not mediate the effect of managerial ownership and profitability on firm value significantly, but it has a significant mediating effect of leverage and firm size on firm value. Finally, ERM significantly contributes to the firm value.

Keywords: *Enterprise Risk Management, Managerial Ownership, Profitability, Leverage, Firm Size, Firm Value*

1. RESEARCH BACKGROUND

[1] stated that the rapid development of the economy has made Enterprise Risk Management (ERM) an important part of the company in maintaining the company's performance and profitability level. In fact, according to [2], Enterprise Risk Management enables the management to operate more effectively in a risky environment. [3] argued that Enterprise Risk Management is part of a comprehensive business strategy that aims to protect and increase the shareholders' value. The increase in shareholders' value also has a good impact on firm value. A good firm value can encourage investors invest in the firm. Several previous studies which discussed about the effect of Enterprise Risk Management on firm value have shown inconsistent results. [4] found that ERM disclosure positively and significantly affect firm value. The existence of ERM disclosure helps stakeholders in assessing the company's prospects. The respective results indicate that there is no consistency between the theory and the existing findings. So, there is still a gap between the variables above. Therefore, it is necessary to review the direct and indirect effects of the determinant factors of firm value such as ownership, profitability, leverage, and company size through the Enterprise Risk Management as an intervening variable.

2. LITERATURE REVIEW

2.1. The Determinant Factors of Firm Value

Firm value is a condition which is achieved by a firm as a reflection of the public's trust toward the firm, after it has gone through the process of activities for years since it was established, at the extent to which it is able to earn profit in a certain period at an acceptable level.

[5] quoted that the agency approach has considered the managerial ownership structure as a tool to reduce conflict in the company, because managers are the internal parties of the company who are given the rights and responsibilities in achieving the company goals, along with shareholders as decision makers for the achievement of the company goals. Profitability is the company's ability to earn profits in an effort to increase the shareholders' value. So, it is important for a company to generate high profitability. High profitability will illustrate that the company's prospects are good for the future according to [4].

Leverage is divided into two categories according to [5], consisting of financial leverage and operating leverage. Financial leverage is the condition in which the fixed-income instruments is used in the company's capital structure. In this theory, the leverage is high, if the percentage of the capital structure in the form of debt and shares is high as well. Meanwhile, operating leverage is the condition in which the fixed costs are used in company operations. This means high leverage, if fixed costs cover the most percentage of total costs.

According to [1], company size is a value that shows the company size, because in general, large companies disclose more information than do small companies.

2.2. The Development of Hypotheses

2.2.1. The Effect of Managerial Ownership on Firm Value

The increasing number of shares owned by managers through managerial ownership, will motivate management performance. The results of the studies conducted by Ningsih (2013) in [6] revealed that managerial ownership positively affects firm value [7] [8]. So, in this study, the first hypothesis could be developed as follow:

H₁: Managerial ownership positively affects firm value.

2.2.2. The Effect of Profitability on Firm Value

[10] stated that profitability positively affects firm value. This statement is supported by [4] which revealed that profitability positively influences firm value. Because of high profitability earned by the company, the company value is high. So, in this study, the second hypothesis could be developed as follow:

H₂: Profitability positively affects firm value.

2.2.3. The Effect of Leverage on Firm Value

The results of the research conducted by [10] stated that leverage significantly and negatively affects firm value. This study is in line with [11] which revealed that leverage has a significant and negative effect on firm value. So, the third hypothesis of this study could be postulated as follow:

H₃: Leverage negatively affects firm value.

2.2.4. The Effect of Firm Size on Firm Value

[10] in their research concluded that firm size positively affects firm value. The same result from [12] showed that company size affects firm value significantly. This is similar with [4], who also found the same result in their research, concluding that company size significantly and positively affects firm value. Based on their studies, the fourth hypothesis could be postulated as follow:

H₄: Firm size positively affects firm value.

2.2.5. The Effect of ERM on Firm Value

The study by [9] revealed that ERM positively affects firm value. Furthermore, [4] stated that ERM disclosure significantly and positively affects firm value. So, according to previous studies, the fifth hypothesis can be developed as follow:

H₅: Enterprise Risk Management positively affects firm value.

2.2.6. The Effect of Managerial Ownership on ERM

[14] argued that the higher the managerial ownership in a company is, the higher the management's responsibility in decision making will be, therefore, ERM becomes more important and more widely applied. This argument supports the result of Siswanto (2013) in [13], which found that managerial ownership positively affects risk-management disclosure. So, the sixth hypothesis can be derived as follow:

H₆: Managerial ownership positively affects Enterprise Risk Management.

2.2.7. The Effect of Profitability on ERM

Companies with high profitability will face high risk as well. This encourages companies to disclose wider risk information. Thus, companies that have high profitability, need to implement the corporate risk management. However, according to [14], profitability has no influence on ERM disclosure. Referring to this research, the seventh hypothesis was developed as follow:

H₇: Profitability negatively affects Enterprise Risk Management.

2.2.8. The Effect of Leverage on ERM

The study of [15] found that leverage has no significant effect on Enterprise Risk Management disclosure. However, the study by [2] explained that leverage has a significant and negative effect on Enterprise Risk Management. Thus, based on the study by [2], we postulated the eighth hypothesis, namely:

H₈: Leverage negatively affects Enterprise Risk Management.

2.2.9. The Effect of Firm Size on ERM

[16] stated that the implementation of ERM is positively connected to firm size. This result is similar with [17] and [1], concluding that firm size significantly and positively affects ERM disclosure. So, the ninth hypothesis can be stated as follow:

H₉: Firm size positively affects Enterprise Risk Management.

2.2.10. The Mediating Effect of ERM on the Effect of Managerial Ownership on Firm Value

Based on the study by Siswanto (2013) in [13], which revealed that managerial ownership positively affects ERM

(H₆), and the studies by [4] and [9], which showed that ERM has a positive effect on firm value (H₅), the tenth hypothesis in this study can be formulated as follow:

H₁₀: ERM positively mediates the effect of managerial ownership on firm value.

2.2.11. The Mediating Effect of ERM on the Effect of Profitability on Firm Value

According to H₅ and H₇ postulated above, this study also tested the transitivity effect of ERM toward the impact of profitability on firm value as postulated in the hypothesis below:

H₁₁: ERM negatively mediates the effect of profitability on firm value.

2.2.12. The Mediating Effect of ERM on the Effect of Leverage on Firm Value

Based on H₅ and H₈ which are postulated above, this study also tested the transitivity effect of ERM toward the effect of leverage on firm value as postulated in the hypothesis as follow:

H₁₂: Enterprise Risk Management negatively mediates the effect of leverage on firm value.

2.2.13. The Mediating Effect of ERM on the Effect of Firm Size on Firm Value

Based on H₅ and H₉ which are postulated above, this study also tested the transitivity effect of ERM toward the effect of firm size on firm value as postulated in the hypothesis below:

H₁₃: Enterprise Risk Management positively mediates the effect of firm size on firm value.

2.2.14. The Role of Enterprise Risk Management in Increasing Firm Value

Based on the theory mentioning that companies conducting Enterprise Risk Management will have a higher firm value than those that do not, the next hypothesis is postulated as follow:

H₁₄: Enterprise Risk Management plays a role in increasing firm value.

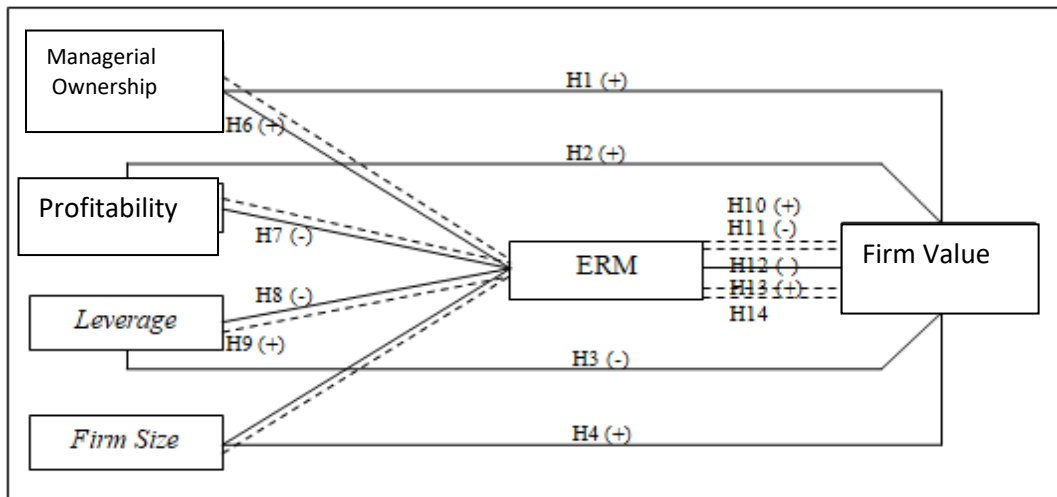

Figure 1 Hypothesis Development Framework

3. RESEARCH METHODS

3.1. Population and Samples

This study has the samples consisting of manufacturing companies in consumer-goods sector listed in the Indonesia Stock Exchange (IDX) within the period of 2016 – 2018. We used the purposive sampling technique during the data collection process.

3.2. The Operationalization of Variables

Firm Value is able to provide maximum prosperity for shareholders, when share prices increase. Firm value is measured by:

$$\text{Tobin's Q} = \frac{\text{MVS} + \text{D}}{\text{TA}}$$

Tobin's Q: Firm value

MVS: The market value of shares obtained from multiplying the number of shares outstanding with the share price.

D: Market value of debt, and TA: Total assets

Enterprise Risk Management (ERM) is a process in managing overall corporate risk that covers all parts of risk, location, and business activities. ERM is measured by:

$$ERM = \frac{\text{The number of ERM}}{108}$$

Managerial Ownership is the percentage of managerial share ownership compared to outstanding shares, which is measured by the formula:

$$KM = \frac{\text{The Number of Shares Owned by The Manager}}{\text{The Number of Shares Outstanding}} \times 100\%$$

Profitability is the company's capability to generate profits as an effort to increase the shareholders' value. Therefore, profitability can be measured by the formula:

$$ROA = \frac{EAT}{\text{Total Asset}}$$

Leverage is a ratio that states the relationship between debt and total equity or company assets. Leverage can be measured by:

$$\text{Leverage} = \frac{\text{Total Liability}}{\text{Total Asset}}$$

Firm Size describes the average total net sales, total assets and changes in capital for the year concerned to several years, which is measured by: **Size = Ln (Total Aset)**

3.3. Model Analysis

In this research, the regression analysis and path analysis were applied in data analysis process. The empirical models of regression in this research are formulated as follows:

Structural Equation Model 1:

$$\text{Tobin's Q} = \gamma_1.KM + \gamma_2.ROA + \gamma_3.LEV + \gamma_4.FZ + \gamma_5.ERM + \epsilon_1$$

Structural Equation Model 2:

$$ERM = \beta_1.KM + \beta_2.ROA + \beta_3.LEV + \beta_4.FZ + \epsilon_2$$

And the path analysis model in this study is as follows:

Table 1 Path Analysis

Effect	KM → ERM → Tobin's Q	ROA → ERM → Tobin's Q	LEV → ERM → Tobin's Q	FZ → ERM → Tobin's Q
Direct	γ ₁	γ ₂	γ ₃	γ ₄
Indirect	β ₁ .γ ₅	β ₂ .γ ₅	β ₃ .γ ₅	β ₄ .γ ₅
Total	γ ₁ + β ₁ .γ ₅	γ ₂ + β ₂ .γ ₅	γ ₃ + β ₃ .γ ₅	γ ₄ + β ₄ .γ ₅

Source: Data Analysis Results (2020)

4. RESULTS AND DISCUSSIONS

The regression equation in model 1 is estimated as follow:

$$\text{Tobin's Q} = -8.631 + 53.310 KM + 16.348 ROA - 0.656 LEV + 0.293 FZ + 0.387 ERM$$

The regression equation in model 2 is estimated as follow:

$$ERM = \beta_1 KM + \beta_2 ROA + \beta_3 LEV + \beta_4 FZ + e_2$$

$$ERM = -4.21 + 0.150 KM - 0.257 ROA - 2.47 LEV + 0.034 FZ$$

Table 2 Path Analysis Test Results

Effect	KM → ERM → Tobin's Q	ROA → ERM → Tobin's Q	LEV → ERM → Tobin's Q	FZ → ERM → Tobin's Q
Direct	0.406	0.536	-0.078	0.293
Indirect	0.000	-0.002	-0.011	0.013
Total	0.406	0.534	-0.089	0.306

Source: Data Analysis Results (2020)

The Effect of Managerial Ownership on Firm Value

The first hypothesis test (H₁) shows that managerial ownership significantly and positively affects firm value. This result conforms with [7] and Ningsih (2013) in [6].

The Effect of Profitability on Firm Value

The second hypothesis test (H₂) shows that profitability significantly and positively affects firm value. This result is in line with [9] [4] [11] [18].

The Effect of Leverage on Firm Value

The third hypothesis test (H_3) reveals that leverage does not significantly and negatively affect firm value. So, this result does not support the findings from previous research conducted by [10] and [11], which stated that leverage significantly and negatively affects firm value.

The Effect of Firm Size on Firm Value

The fourth hypothesis test (H_4) shows that firm size has a significant and positive effect on firm value. This conforms the results of the researches conducted by [9] [12] [4].

The Effect of ERM on Firm Value

The fifth hypothesis test (H_5) reveals that ERM does not significantly and positively affect firm value. This result does not support the previous researches conducted by [9] and [4], which stated that ERM significantly and positively affects firm value.

The Effect of Managerial Ownership on ERM

The sixth hypothesis test (H_6) shows that managerial ownership does not have a significant and positive effect on ERM. This result does not support the previous research by Siswanto (2013) in [13], which stated that managerial ownership positively affects ERM.

The Effect of Profitability on ERM

The seventh hypothesis test (H_7) concludes that profitability does not significantly and negatively affect ERM. This result supports the previous research conducted by [14], which stated that profitability has no effect on ERM disclosure.

The Effect of Leverage on ERM

The result of the eighth hypothesis test (H_8) indicates that leverage does not significantly and negatively affect ERM. This is in line with previous researches conducted by [15] [2] [13] concluding that leverage does not significantly affects ERM.

The Effect of Company Size on ERM

The ninth hypothesis test result (H_9) shows that company size has a significant and positive effect on ERM. This result is in line with [17] [16] [1], which stated that company size has no positive effect on ERM.

The Mediating Effect of ERM on the Effect of Managerial Ownership on Firm Value

The result of the tenth hypothesis testing (H_{10}) shows that ERM does not significantly mediate the effect of managerial ownership on firm value positively. Thus, the positive effect of managerial ownership on firm value does not get more positive when ERM increases. Therefore, this result is in line with [7], concluding that ERM does not significantly mediate the effect of managerial ownership on firm value.

The Mediating Effect of ERM on the Effect of Profitability on Firm Value

The result of the eleventh hypothesis test (H_{11}) shows that ERM does not significantly mediate the negative effect of profitability on firm value. Hence, the positive effect of profitability on firm value does not become more positive when ERM increases.

The Mediating Effect of ERM on the Effect of Leverage on Firm Value

The twelfth hypothesis test (H_{12}) results that ERM has a negative and significant mediating effect of leverage on firm value. In other words, when ERM increases, the impact of ERM on firm value is increasing in negative direction. So, this result indicates that in the consumer goods industry, the pecking-order theory applies.

The Mediating Effect of ERM on the Effect of Firm Size on Firm Value

The result of the thirteenth hypothesis test (H_{13}) shows that ERM significantly and positively mediates the effect of firm size on firm value positively. The effect of firm size on firm value will be more positive, when ERM increases. Because of being in line with the increasing size of the company, it is very important to implement ERM in order to increase firm value. The greater the company assets is, the greater the risk faced by the company will be, in the efforts to increase firm value.

The Role of ERM in Increasing Firm Value

The twelfth and the thirteenth hypothesis test results show that ERM significantly mediates the effect of leverage and firm size on firm value, and then the fourteenth hypothesis test (H_{14}) results an evidence that ERM can play a role in increasing firm value. For companies with high debt-ratio to increase their firm values, it requires intensive ERM implementation. Likewise, companies with large assets need to apply ERM intensively so that the risk of using large assets for achieving company targets can be minimized or reduced to a tolerable residual-risk limit.

5. CONCLUSIONS AND SUGGESTIONS

5.1. Conclusions

Based on the results of the statistical testings of the hypotheses that have been carried out in this study, it can be concluded as follows:

- a. Managerial ownership, profitability, and firm size significantly and positively affect firm value. On contrast, leverage and ERM have no significant effect on firm value. Meanwhile, only firm size has a significant and positive effect on ERM.
- b. Furthermore, ERM significantly mediates the effect of leverage on firm value negatively. In addition, ERM significantly and positively affects the influence of firm size on firm value. However, ERM does not

significantly mediate the effect of managerial ownership and profitability on firm value positively.

- c. Visually, ERM plays a role in increasing firm value among manufacturing companies in the consumer goods industry.

5.2. Suggestions

Based on the findings in this study, it can be suggested as follows:

- a. For companies with high debt-ratio in an effort to increase firm value, they should implement the ERM intensively. To increase firm value when implementing ERM, companies should reduce their leverage and increase the size of their assets (firm size).
- b. The determinant factors of firm size on firm value in this study only use managerial ownership, profitability, leverage, and ERM. So, in future research, it is expected to add other variables such as liquidity and firm growth variables so that the research can be more specific to identify how much the increase or decrease in total assets owned by companies.
- c. The companies used as research samples are only limited to manufacturing companies in the consumer goods industry. Thus, they do not represent all sectors in the IDX. The next research is expected to increase the number of samples by involving other industrial sectors.

REFERENCES

- [1] Widiawati dan Halmawati, 2018. "Pengaruh Corporate Governance dan Ukuran Perusahaan Terhadap Enterprise Risk Management (ERM) Disclosure (Studi Empiris pada Perusahaan Manufaktur yang Terdaftar di BEI Tahun 2014-2017)." *Jurnal WRA*, Vol. 6, No. 2, Hal. 1281 – 1296.
- [2] Marhaeni, Tiyas dan Hari Yanto, 2015. "Determinan Pengungkapan Enterprise Risk Management (ERM) Pada Perusahaan Manufaktur." *Accounting Analysis Journal*, AAJ 4 (4), Hal. 1 – 22.
- [3] Hoyt, R. E., and A. P. Liebenberg. 2011. The Value of Enterprise Risk Management. *The Journal of Risk and Insurance*, 78 (4), pp.795-822.
- [4] Devi, Sunitha, I Gusti Nyoman Budiasih, dan I Dewa Nyoman Badera, 2017. "Pengaruh Pengungkapan Enterprise Risk Management dan Pengungkapan Intellectual Capital Terhadap Nilai Perusahaan." *Jurnal Akuntansi dan Keuangan Indonesia*, Vol. 14 No.1, Hal. 20-45.
- [5] Brigham, Eugene F dan Ehrhardt., Michael C. 2008. *Financial Management: Theory and Practice*. Twelfth Edition. New York: South Western.
- [6] Ayu, Putu Cita dan Ni Komang Sumadi, 2019. "Pengaruh Kepemilikan Institusional dan Kepemilikan Manajerial Terhadap Nilai Perusahaan." *Widya Akuntansi dan Keuangan Universitas Hindu Indonesia*, Hal. 87 – 104.
- [7] Handayani, Bestasi Dwi, 2017. "Mekanisme Corporate Governance, Enterprise Risk Management, dan Nilai Perusahaan Perbankan." *Jurnal Keuangan dan Perbankan*, Vol. 21 (1): 70-81.
- [8] Tambalean, Friko Allan Kevin, Hendrik Manossoh dan Treesje Runtu, 2018. "Pengaruh Kepemilikan Manajerial dan Kepemilikan Institusional Terhadap Nilai Perusahaan Pada Perusahaan Sektor Industri Barang Konsumsi di BEI." *Jurnal Riset Akuntansi Going Concern* 13(4), 465 – 473.
- [9] Iswajuni, Iswajudi, Arina Manasikana and Soengeng Soetedjo, 2018. "The Effect of Enterprise Risk Management (ERM) on Firm Value in Manufacturing Companies Listed on Indonesia Stock Exchange Year 2010-2013", *Asian Journal of Accounting*, Vol. 3 No. 2, pp. 224-235.
- [10] Timbuleng, Ferlen, Sientje C. Nangoy, dan Ivvone S. Saerang, 2015. "Pengaruh Faktor Likuiditas, Leverage, NPM dan ROI terhadap Nilai Perusahaan (Studi pada Perusahaan Consumer Goods yang terdaftar di Bursa Efek Indonesia Periode 2010-2013)." *Jurnal EMBA*, ISSN 2303-1174, Vol. 3, No. 2, Hal. 546-557.
- [11] Sari, Pt Indah Purnama dan Nyoman Abundanti, 2014. "Pengaruh Pertumbuhan Perusahaan dan Leverage Terhadap Profitabilitas dan Nilai Perusahaan." *Jurnal Ekonomi dan Bisnis Universitas Udayana*, Hal. 1427-1441.
- [12] Sanjaya, Cynthia Kartika dan Nanik Linawati, 2015. "Pengaruh Penerapan Enterprise Risk Management dan Variabel Kontrol Terhadap Nilai Perusahaan di Sektor Keuangan", *Jurnal Finesta Universitas Petra*, Vol. 3 No.1.
- [13] Sulistyaningsih dan Barbara Gunawan, 2016. "Analisis Faktor-Faktor yang Mempengaruhi Risk Management Disclosure (Studi Empiris Pada Perusahaan Manufaktur yang Terdaftar di Bursa Efek Indonesia Tahun 2012-2014)." *Riset Akuntansi dan Keuangan Indonesia*, 1(1).
- [14] Erliani, Dini. 2019. "Pengaruh Karakteristik Perusahaan, Corporate Governance dan Konsentrasi Kepemilikan Terhadap Pengungkapan Enterprise Risk Management pada Perusahaan Property dan Real

Estate yang Terdaftar di BEI Periode 2014 – 2018.”
Skripsi Universitas Pancasakti Tegal.

[15] Cecasmi, Jetmi Ade dan Samin, 2017. “Pengaruh Dewan Komisaris, Leverage, dan Struktur Kepemilikan Terhadap Pengungkapan Enterprise Risk Management (ERM).” *Equity Jurnal Ekonomi, Manajemen, Akuntansi*, Vol. 20 No.2, Hal. 75-90.

[16] Mardessi, Sana Masmoudi and Sonda Daoud Ben Arab, 2018 “Determinants of ERM implementation: the case of Tunisian companies.” *Journal of Financial Reporting and Accounting* Vol. 16 No.3 pp. 443-463.

[17] Syifa, Layyinatasy, 2013. Pengaruh Ukuran Perusahaan, Leverage, Konsentrasi Kepemilikan, Reputasi Auditor dan Chief Risk Officer Terhadap Pengungkapan Enterprise Risk Management. Semarang : Universitas Negeri Semarang.

[18] Kumalasari, 2014. “Faktor-Faktor Yang Berpengaruh Terhadap Luas Pengungkapan Manajemen Risiko.” *Accounting Analysis Journal*, Vol.3, No.1.