

Design and Implementation of Data Acquisition Device and Instrumentation Based on Microcontroller for Electric Motorcycle

Agus Ulinuha^{1,*} Jatmiko¹ Almas Ghulam Riza¹

¹Department of Electrical Engineering, Universitas Muhammadiyah Surakarta, Indonesia

*Corresponding author. Email: Agus.Ulinuha@ums.ac.id

ABSTRACT

Along with intensive people activities in different places, the demand on transportation increases. For some dense road, motorcycle might be the better choice due to its ability to move flexibly. This may lead to massive use of motorcycle powered by fossil fuel engine. Beside causing severe air pollution, this also causes high fuel consumption. Electric motorcycle is expected to be the answer for both problems, since it does not cause air pollution and does not require fossil fuel to operate. However, this motorcycle solely depends on energy stored in battery that needs some time to recharge. This difficulty makes the good points of electric motorcycle unattractive. The development of battery with high capacity and requires shorter time to charge is still on process. Therefore, optimal battery energy use is another solution for this case. This may be assisted with instrumentation system that presents some useful information for the driver regarding real time system operating condition. This paper presents development of instrumentation system including data acquisition that employs a microcontroller of Arduino Mega. A number of sensors are employed in the system including magnet sensor, current and voltage sensors. The system is implemented in a motorcycle powered by 1000 W, 48/36 V DC motor energized by 17.5 Ah 48 V Lithium-Ion Battery. Some measured data are processed and presented in an LCD on the dashboard, including RPM, speed, torque, the distance travelled, the remaining battery capacity and the distance that may still be achieved. An automatic data logger of DS3231RTC is used for recording the data and it is saved in a SD Card Memory. For verification purpose, the displayed data are benchmarked with those measured with standard measurement devices. It was confirmed that the data presented by the instrumentation system is sufficiently accurate.

Keywords: *Data Acquisition, Instrumentation System, Real-time Operating Condition, Optimal Energy Use, Data Accuracy.*

1. INTRODUCTION

Intensive people movement is becoming a phenomenon related with economic growth and country development. On the other hand, this would be a dilemma on how to enhance people mobility and, at the same time, to reduce congestion, traffic accident and air pollution. Urban mobility is reported to accounts for 40% of all carbon dioxide emissions of road transport and up to 70% of other pollutants from transportation sector [1]. The effort may be taken by reducing gas emission while letting the people move for their activities.

Another concern on transportation activity is the massive use of vehicle or motorcycle powered by fossil fuel-based engine. This activity may cause intensive use

of fossil fuel leading to persistent reduction of fuel deposit. Together with other sectors that also consume fossil fuels, this will lead fuel deposit to finish faster. Considering this trend, the reserve of fossil fuel and its depletion was calculated resulting in the prediction that the deposit of oil, coal dan gas will be depleted approximately in 35, 107, 37 years, respectively [2]. Environmental effects of fossil fuel consumption is another great concern worldwide [3]. Transportation sector seems to be the one responsible for the both problems. In one hand this sector takes much fuel causing considerable fuel deposit reduction, and, on the other hand, this causes pollution problem. It would be a dilemma, while transportation sector is required by people, but it may lead to some drawbacks. Without a

strategic intervention, the problem of fuel consumption and CO₂ emission may persist or even rapidly increase [4]. Looking for answers where transportation system is operated using resources other than fossil fuel that concurrently implies minimum environmental problems would be the best option for this situation [5].

Electrical energy is the most feasible energy for different uses, including transportation system [6]. This is due to that the energy can be easily generated using several resources and can be extensively used for different applications. The use of electrical energy for transportation system requires fundamental change of the transportation devices [7]. The prime mover of the device is replaced with electric motor and the energy is stored in a battery [8]. The development of electric transportation system is still in the beginning stage and some researches are still necessary to improve the product and how some drawbacks may be resolved.

Electric transportation system is well-researched topic. The topic on this idea is extensive including policy, simulation, hardware and software development, infrastructure modification, economic analysis, and future development. Research on motor application for electric transportation device covers some topics. One of them is modification of prime-mover and its further innovation [9] that enables enhancement to extend the range of driving [10]. Regulating power supply for the motor leading to enhancing prime mover performance using new approach is another topic in this area [11]. Control system is the topics that achieve extensive attentions from simulation to real application, including traction control using conventional control methods [12], modifying the motor magnetic field to enable better response [13] and development of control system that enables driving the motor using novel approaches [14]. However, fewer publication is found in real implementation of the control strategy for a prototype system [15] as well as development of the real system [16].

One of important issues on electric transportation device is storage and the related topics. Research on this topic includes material development and modification achieving storage advantages [17], [18], charging control strategy [19] including the scheme of regenerative braking [20] that allows maintaining the battery lifetime. Battery follows time variable and nonlinear characteristics. Furthermore, battery capacity reduction is influenced by factors including driving load and operational condition. Determining battery capacity is not an easy task. Research on this topic in both theory and practical application is getting sufficient attention focusing on energy management optimization, life cycle extension, cost reduction and safe application on electric

vehicle. However, the real-time, accurate estimation of its state is challenging. The classification of estimation method to accurately predict the State of Charge (SoC) of battery is still becoming interesting discourse covering the algorithm, advantages, drawbacks, and error estimation [21].

Based on the aforementioned description, this paper proposes an embedded system for data measurement and acquisition for an electric motorcycle. This enables providing some essential information displayed on the dashboard. The developed system in this research is a complete electric motorcycle including prime mover, controller, power storage, and some physical components. In the developed instrumentation system, some sensors are required for measurement purpose. Since some data or information may not be directly displayed from measurements but must proceed some calculations, a processor is assigned to carry out these tasks. The processor receives measured data from sensors and calculates them to result in some necessary information. For measurement and acquisition, the system relies on Arduino Mega as processing device. The data and information from both measurement and calculation are presented in a TFT Shield. These include current, voltage, power, energy consumption, speed, mileage and some other data depending on the driving needs. These data and information are necessary for effective driving leading to maximum performance with the highest efficiency.

The developed system has been tested and the measurement results were benchmarked. The measurement from standard measurement devices were used as reference where the sensors reading are compared with. It was confirmed that the measurement from the sensors is close with that given by measurement devices. Therefore, the calculation results generated by the processor will be about accurate. This instrumentation system may be further developed for providing more comprehensive information that enables developing decision support system on motorcycle driving.

2. SYSTEM DEVELOPMENT

2.1. System Design

For the purpose of instrumentation system development, a real plant must be constructed. This includes a complete motorcycle powered by DC motor. A second-hand motorcycle was used in this project by replacing the engine with DC motor, 36 Volt, 1000 W. The controller for the motor was also developed but not discussed in this paper. The design of instrumentation system is given in Fig. 1

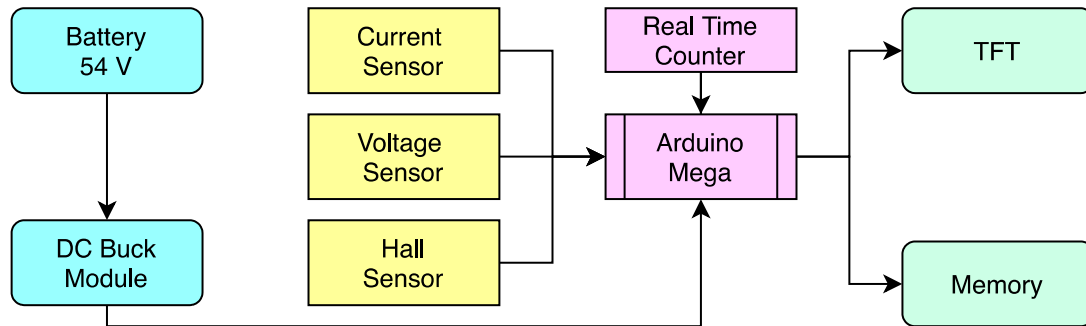

Figure 1 Block Diagram of Data Acquisition Instrumentation System

Figure 1 illustrates a block diagram of a data acquisition instrumentation system, using Arduino Mega as a microcontroller, and voltage sensor, current sensor, magnetic sensor as data reader. A 3.5-inch TFT Shield is used for data viewer. This features 480 x 320 resolution, and compatible with Arduino Uno and Mega. The system is supplied with 54-Volt battery and this should be reduced using the DC Buck Module to 12 Volts to supply Arduino.

To get the current data, ACS712 30-Ampere current sensor is connected in series between battery and DC motor that measures the current flowing from the battery to the motor. For the purpose of voltage measurement, a voltage divider consisting of 2 resistors of 10 kΩ and 1 kΩ are employed to enable measuring battery voltage within the meter range. Speed data is obtained through a magnetic sensor that detects the magnetic interaction due to wheel rotation. This record is further processed to present the speed data. All of parameters displayed in TFT will also be stored in memory. An automatic data logger DS3231RTC is used for recording the data and they are saved in a SD Card Memory

For data acquisition instrumentation design, a program should be developed. For the program that drives the system, the Arduino IDE software is used such that the sensors may run properly to read the data. For designing the board, Autodesk Eagle PCB (Printed Circuit Board) 2009 Software is used that enables printing PCB (Printed Circuit Board). It is used to assemble all the components on board.

2.2. System Implementation

The instrumentation of data acquisition consists of the mainboard Arduino Mega in the backside of the mainboard as shown in figure 2. To connect Arduino with the mainboard a long male pin header is used. The pin is soldered such that Arduino can plugin into the main board. The main board also consists of voltage and current sensor where the pins are soldered into the copper at the main board. This connects to analog pin of Arduino. A T-block pin socket is used to connect the input from battery. Two DC buck step-downs in the mainboard are used to decrease the 54-V battery voltage

to 12-Volt that supplies the Arduino Uno and to 5-Volt that supplies the sensors. There is molex socket in the left side of the mainboard used to connect the magnet sensor placed facing toward the wheel to detect the magnetic interaction due to wheel rotation. On the centre of mainboard, there are two 8 pin and 6 pin molex sockets that serve to connect the TFT. These connections use rainbow cable. When the mainboard is connected to the battery or source, the system will turn on, and TFT will display the programmed parameters.

The instrumentation system mainboard is placed in front side of the bicycle. This placement is aimed to facilitate the easy cabling of the mainboard with TFT. For the magnetic sensor attached on the rear wheel, connection to the mainboard uses molex socket. When the mainboard is supplied by the battery, the system is active and magnet sensor works to detect the magnetic interaction because of wheel rotation. When the magnet on the wheel is detected by the sensor, it will generate HIGH signal in Arduino port, and therefore the Arduino will process the signal and count the number of wheel rotation, and display RPM and velocity parameter.

All sensors work by reading the data parameter and send them to Arduino as microprocessor. The Arduino will process the data into some parameters that are needed by driver. These parameters are displayed in TFT and saved in the memory. In the rear view of the mainboard (Fig. 2) there are Arduino, micro SD card module and RTC (Real Time Counter) that are used to store the data parameter from Arduino. In the TFT screen, some data are displayed and can be clearly seen by the driver.

2.3. System Operation and Testing

Once the instrumentation system has been completely developed, then this may be attached to the real system. Some works of wiring, cabling and physically installing in the motorcycle were carefully carried out. Running and checking the system were also conducted including data presentation in TFT shield. The installation of instrumentation board at motorcycle and the display of TFT Shield are shown in Fig.3.

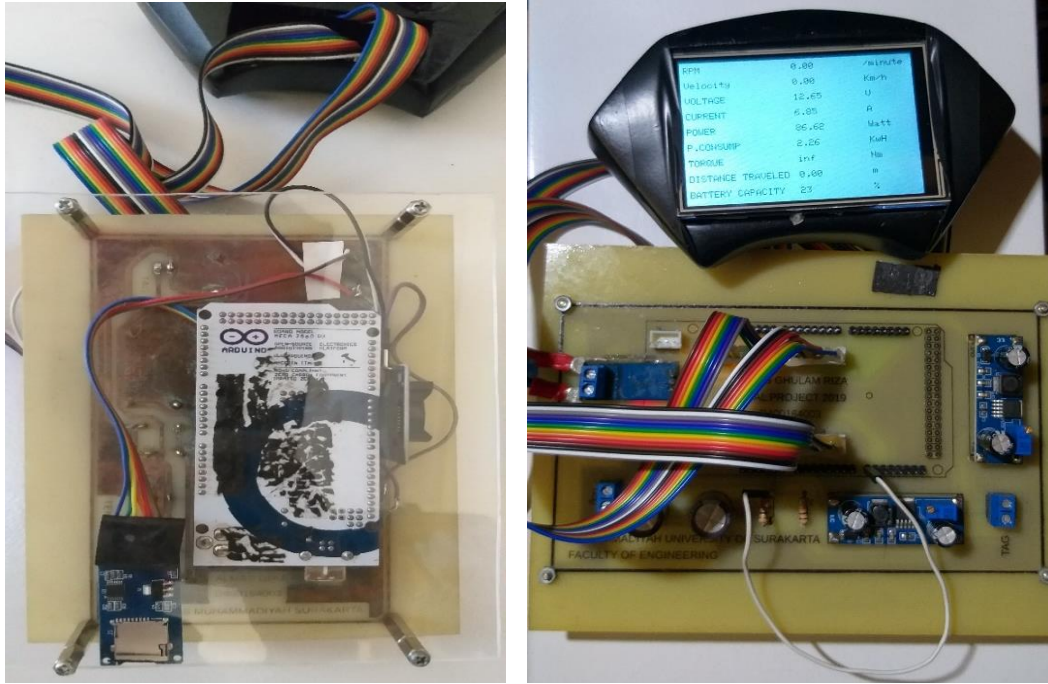

Figure 2 Instrumentation mainboard from rear and front view

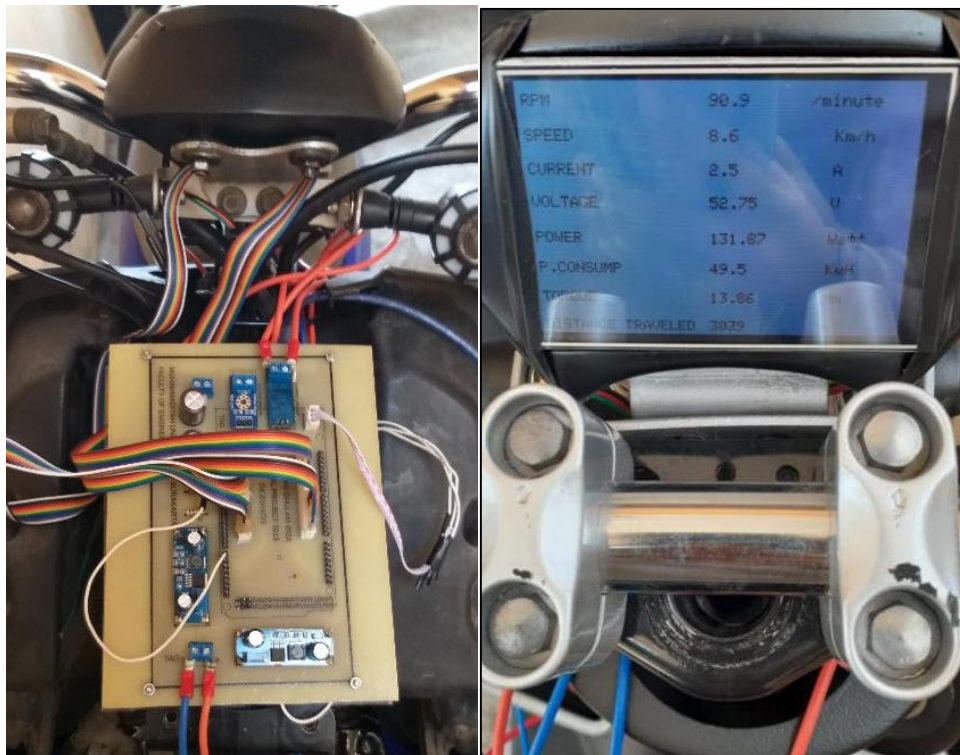

Figure 3 The instrumentation system attached in motorcycle and the TFT display

For comparison purpose, the data and information presented in TFT are benchmarked with those measured with standard measurement devices. The data of voltage, current and power were compared with the standard meter. While the measurement of wheel rotation is compared with that recorded by tachometer. The data presented in TFT display includes current, voltage, power, RPM, speed, torque and data travelled.

3. RESULT AND DISCUSSION

For the purpose of system testing and measurement, the developed electric motorcycle was operated. Some data displayed in the TFT shield was recorded and benchmarked with those given by measurement devices. It is assumed that the reading given by the measurement devices are sufficiently accurate such that the

instrumentation reading can be compared to. There are 10 samples recorded in the testing section and are given in Table 1. The comparison with the reading of the meters is also presented. Inspection on the table indicates that the

results presented in the TFT are sufficiently accurate. It is indicated that the data presented in the TFT display are very close with those measured by the device.

Table 1. The data presented in TFT and given by the meters

Sample	Voltage Measurement		Current Measurement		Power Measurement	
	Meter	TFT	Meter	TFT	Meter	TFT
1	10.05	10.26	0.033	0.3	3.3165	3.078
2	10.05	10.21	0.29	0.3	2.9145	3.063
3	12.03	11.98	0.38	0.37	4.5714	4.4326
4	12.08	12.03	0.44	0.47	5.3152	5.6541
5	15.05	14.72	0.47	0.44	7.0735	6.4768
6	15.05	14.77	0.5	0.66	9.933	9.8959
7	17.08	16.54	0.55	0.78	13.3224	12.2396
8	17.05	16.49	0.6	0.65	11.0825	11.0483
9	20.01	19.23	0.8	1.11	22.2111	17.1147
10	22.03	22.77	1	1.8	39.654	28.6902

From the mechanical standpoint, the measurement of RPM and speed were also carried out. The test was conducted by running the motorcycle while it's wheel freely rotating and was not driven in the real road. This test is considered to be sufficient since the measurement was taken for comparing RPM reading and, therefore, there is no need to drive the motorcycle on the real road.

The measurements were conducted by tachometer and magnetic sensor. The magnetic sensor was employed to measure the RPM by detecting the attached magnetic strip on the rotating wheel. Every detection of magnetic strip indicates that one rotation has happened. The more

magnetic sensor detection, the higher the rpm and the faster the rotation. Table 2 indicates the comparison between the reading of magnetic sensor presented in TFT display compared with that given by Tachometer.

It can be observed that the results displayed in TFT are sufficiently close with those given by Tachometer. Please be noted that the velocity of motorcycle from the tachometer reading is calculated manually considering the outer wheel radius. While the speed presented in TFT is from the RPM of Magnetic Sensor reading, which are further calculated by the processor.

Table 2. The rpm of motorcycle's wheel given by tachometer and presented in TFT

No	RPM Sensor		Velocity (km/h)	
	Tachometer	TFT Display	Tachometer ^{*)}	TFT Display
1	131	132	12.30	12.44
2	175	180	16.50	16.96
3	230	228	21.70	21.48
4	276	276	25.97	26.01
5	321	312	30.22	29.41
6	369	372	34.78	35.05
7	560	564	52.74	53.15
8	811	820	76.46	77.28
9	910	928	85.73	87.46
10	1298	1291	122.33	121.67

**) The speed is manually calculated considering wheel radius*

After some data have been successfully measured and benchmarked with standard measurement devices, the more comprehensive data and information may be presented in TFT display. Table 3. indicates the complete data presented in TFT display. These include the input

parameters where the other data are measured accordingly. Some data can be directly taken from the measurements (RPM, Voltage, Current) while the others must be calculated by the processor.

Table 3. The complete data of TFT Display

No	RPM	Speed (km/h)	Current (A)	Volt (V)	Instrumentation			
					Power (Watt)	Energy (Wh)	Torque (N.m)	Battery Capacity (%)
1	98	9.236	0.37	52.7	19.499	0.6	1.901	75.641
2	130	12.252	0.44	52.8	23.232	1.31	1.707	76.923
3	162	15.268	0.52	53.04	27.581	2.62	1.627	80.000
4	220	20.735	0.81	52.72	42.703	3.26	1.855	75.897
5	260	24.504	0.98	53.25	52.185	6.9	1.918	82.692
6	320	30.159	1.85	52.77	97.625	2.45	2.915	76.538
7	420	39.584	2.07	52.6	108.882	3.5	2.477	74.359

The real testing was carried out by driving the motorcycle on the real road. It was driven by a 67 kg person at January 11, 2020. The data of testing as recorded in Micro SD Card Memory is presented at Table 4. It may be observed from the Table that the complete data are provided by the instrumentation system. Besides those presented in TFT display, the data may also be retrieved from the memory. It may also be further

observed that for the achieved distance, the consumption of energy is about small. This energy consumption reduces battery capacity of 4.27%. Therefore, the developed motorcycle powered by DC Motor is very efficient and may be further developed to the real system. However, the focus of this research is development of instrumentation system and verification of the generated data and information.

Table 4. The motorcycle operation data retrieved from Micro SD Memory

Date	Time	Velocity (km/h)	Power (Watt)	Energy (kWh)	Torque (Nm)	Distance (km)	Battery Capacity (%)
11/1/2020	13:44:02	0.003	1.47	0	0.02	1.63	30.90
11/1/2020	13:44:04	2.589	18.76	0.04	6.53	1.65	30.38
11/1/2020	13:44:06	2.675	40.63	0.1	13.68	1.71	27.56
11/1/2020	13:44:08	5.085	47.87	1.15	8.48	1.72	27.31
11/1/2020	13:44:10	5.306	48.22	0.17	8.18	1.73	26.67
11/1/2020	13:44:12	9.213	49.21	0.21	4.81	1.74	26.28
11/1/2020	13:44:14	10.693	53.68	0.25	4.52	1.72	27.44
11/1/2020	13:44:16	10.740	50.49	0.28	4.23	1.71	27.56
11/1/2020	13:44:18	13.361	67.81	0.41	4.57	1.75	25.90
11/1/2020	13:44:20	13.361	59.81	0.4	4.03	1.70	27.95
11/1/2020	13:44:23	15.977	47.63	0.34	2.68	1.71	27.82
11/1/2020	13:44:25	13.361	60.71	0.47	4.09	1.72	27.31
11/1/2020	13:44:27	16.125	68.91	0.57	3.85	1.71	27.56
11/1/2020	13:44:29	16.076	85.08	0.76	4.77	1.73	26.79
11/1/2020	13:44:31	15.977	87.47	0.83	4.93	1.73	26.67

4. CONCLUSION

An electric motorcycle powered by 1000 W 36 V DC motor is developed in this study. This motorcycle is equipped with an instrumentation system that features data acquisition. This paper focuses on development of instrumentation system to measure and present the data of real time motorcycle operating condition. This instrumentation system employs Arduino Mega as

microcontroller and a number of sensors for measurements. For presentation of data and information, a 3.5-inch TFT Shield is used for display purpose. Some data may be directly displayed from the measurements, but some of them require further calculations before being displayed. The data generated by instrumentation system were benchmarked with those given by standard measurement devices. The comparison confirms that the data given by instrumentation system are sufficiently accurate. Hence the complete data can be displayed in the

TFT to provide more comprehensive information necessary for optimal driving that achieves both maximum performance and efficiency. The data on instrumentation system indicate that the developed motorcycle shows the performance of good speed and torque with minimum energy consumption. This prototype may be further developed for producing the real DC motor powered motorcycle.

ACKNOWLEDGMENT

The Authors would like to gratefully acknowledge the support of The Directorate of Research and Community Development, The Deputy of Research and Development, The Ministry of Research and Technology, the Government Republic of Indonesia. This research project is under the scheme of Basic Research for the contract number of 86/SP2H/LT/DRPM/2020 at the year of 2020.

REFERENCES

- [1] Space solution esa, "People Mobility | ESA Business Applications," 2017. <https://business.esa.int/funding/invitation-to-tender/people-mobility>.
- [2] S. Shafiee and E. Topal, "When will fossil fuel reserves be diminished?," *Energy Policy*, vol. 37, no. 1, pp. 181–189, Jan. 2009, doi: 10.1016/j.enpol.2008.08.016.
- [3] E. Kakaras, A. K. Koumanakos, and A. Doukelis, "7 - Pressurized fluidized bed combustion (PFBC) combined cycle systems," in *Combined Cycle Systems for Near-Zero Emission Power Generation*, A. D. Rao, Ed. Woodhead Publishing, 2012, pp. 220–233.
- [4] X. Yin *et al.*, "China's transportation energy consumption and CO2 emissions from a global perspective," *Energy Policy*, vol. 82, pp. 233–248, Jul. 2015, doi: 10.1016/j.enpol.2015.03.021.
- [5] A. J. C. Trappey, C. Trappey, C. T. Hsiao, J. J. R. Ou, S. J. Li, and K. W. P. Chen, "An evaluation model for low carbon island policy: The case of Taiwan's green transportation policy," *Energy Policy*, vol. 45, pp. 510–515, Jun. 2012, doi: 10.1016/j.enpol.2012.02.063.
- [6] N. Shaukat *et al.*, "A survey on electric vehicle transportation within smart grid system," *Renewable and Sustainable Energy Reviews*, vol. 81, pp. 1329–1349, Jan. 2018, doi: 10.1016/j.rser.2017.05.092.
- [7] L. Qiu, L. Qian, H. Zomorodi, and P. Pisu, "Global optimal energy management control strategies for connected four-wheel-drive hybrid electric vehicles," *IET Intelligent Transport Systems*, vol. 11, no. 5, pp. 264–272, Jun. 2017, doi: 10.1049/its.2016.0197.
- [8] E. Mese, Y. Yasa, H. Akca, M. G. Aydeniz, and M. Garip, "Investigating operating modes and converter options of dual winding permanent magnet synchronous machines for hybrid electric vehicles," *IEEE Transactions on Energy Conversion*, vol. 30, no. 1, pp. 285–295, Mar. 2015, doi: 10.1109/TEC.2014.2360714.
- [9] J. Ruan and Q. Song, "A Novel Dual-Motor Two-Speed Direct Drive Battery Electric Vehicle Drivetrain," *IEEE Access*, vol. 7, pp. 54330–54342, 2019, doi: 10.1109/ACCESS.2019.2912994.
- [10] L. Tian, L. Wu, X. Huang, and Y. Fang, "Driving range parametric analysis of electric vehicles driven by interior permanent magnet motors considering driving cycles," *CES Transactions on Electrical Machines and Systems*, vol. 3, no. 4, pp. 377–381, Dec. 2019, doi: 10.30941/CESTEMS.2019.00049.
- [11] X. Wu, X. Shi, X. Li, and J. Lei, "Analysis and optimisation of electromagnetic interference in motor drive system," *International Journal of Electric and Hybrid Vehicles*, vol. 12, no. 1, pp. 15–31, Dec. 2019, doi: 10.1504/IJEHV.2020.104261.
- [12] D. Tavernini, M. Metzler, P. Gruber, and A. Sornioti, "Explicit Nonlinear Model Predictive Control for Electric Vehicle Traction Control," *IEEE Transactions on Control Systems Technology*, vol. 27, no. 4, pp. 1438–1451, Jul. 2019, doi: 10.1109/TCST.2018.2837097.
- [13] Q. Chen, S. Kang, L. Zeng, Q. Xiao, C. Zhou, and M. Wu, "PMSM control for electric vehicle based on fuzzy PI," *International Journal of Electric and Hybrid Vehicles*, vol. 12, no. 1, pp. 75–85, Dec. 2019, doi: 10.1504/IJEHV.2020.104251.
- [14] B. E. Elnaghi, H. A. Ibrahim, S. A. Elsayed, and F. Abd-Elkader, "Developed operation of inverter fed induction motor to drive the electric vehicle," *International Journal of Electric and Hybrid Vehicles*, vol. 12, no. 2, pp. 116–129, Jan. 2020, doi: 10.1504/IJEHV.2020.106340.
- [15] B. Wang, X. Zhang, and H. B. Gooi, "An SI-MISO Boost Converter With Deadbeat-Based Control for Electric Vehicle Applications," *IEEE Transactions on Vehicular Technology*, vol. 67, no. 10, pp. 9223–9232, Oct. 2018, doi: 10.1109/TVT.2018.2853738.
- [16] B. Meng, X. Deng, and Z. Song, "Control Strategy of Basic Operation Condition of Hub Electric

- Vehicle,” *Journal of Shandong Jiaotong University*, vol. 02, 2018.
- [17] Y. Ma, P. Duan, Y. Sun, and H. Chen, “Equalization of Lithium-Ion Battery Pack Based on Fuzzy Logic Control in Electric Vehicle,” *IEEE Transactions on Industrial Electronics*, vol. 65, no. 8, pp. 6762–6771, Aug. 2018, doi: 10.1109/TIE.2018.2795578.
- [18] R. Pradeep and T. Venugopal, “Experimental study of lithium-ion battery cooling using mixture of phase change materials,” *International Journal of Electric and Hybrid Vehicles*, vol. 12, no. 2, pp. 168–183, Jan. 2020, doi: 10.1504/IJEHV.2020.106354.
- [19] B.-R. Choi, W.-P. Lee, and D.-J. Won, “Optimal Charging Strategy Based on Model Predictive Control in Electric Vehicle Parking Lots Considering Voltage Stability,” *Energies*, vol. 11, no. 7, Art. no. 7, Jul. 2018, doi: 10.3390/en11071812.
- [20] J. Wu, X. Wang, L. Li, C. Qin, and Y. Du, “Hierarchical control strategy with battery aging consideration for hybrid electric vehicle regenerative braking control,” *Energy*, vol. 145, pp. 301–312, Feb. 2018, doi: 10.1016/j.energy.2017.12.138.
- [21] R. Xiong, J. Cao, Q. Yu, H. He, and F. Sun, “Critical Review on the Battery State of Charge Estimation Methods for Electric Vehicles,” *IEEE Access*, vol. 6, pp. 1832–1843, 2018, doi: 10.1109/ACCESS.2017.2780258.