

# Implementation of Smart Grid System for Alternative Energy Power Plants Sources

Masayu Anisah<sup>1</sup> Yudi Wijanarko<sup>1</sup> Renny Maulidda<sup>1,\*</sup> Johansyah Al Rasyid<sup>1</sup>  
Dimas Prasetya WP<sup>1</sup> M. Dandy Ramadhan<sup>1</sup> Mohammad Noviansah<sup>1</sup>

<sup>1</sup> Politeknik Negeri Sriwijaya

\*Corresponding author. Email: [rennymaulidda@polsri.ac.id](mailto:rennymaulidda@polsri.ac.id)

## ABSTRACT

Electrical energy is included in the most essential needs and cannot be separated from human activities. The electrical energy produced is still dominated by power plants by conventional energy sources so that the use of alternative energy is needed to prevent the limitation of energy sources. Alternative energy that is often used is a source of solar electricity that produces electricity by utilizing sunlight. In an effort to increase and utilize renewable energy sources, researchers seek to design and implement a smart grid system on alternative energy sources. The smart grid system allows users to monitor and control the energy used by analyzing the direct parameters to be assessed. Using this smart grid system can help overcome limitations in monitoring because it can be done remotely. This system uses the ACS712 sensor to detect the current at the DC load, and the PZEM004T sensor for the AC load. It communicates via an IoT-based internet network using ESP 32 with the percentage of errors obtained in the power dc load test resulting in an error rate of 0.012% and in the power AC load testing of 0.064%.

**Keywords:** *Smart Grid System, Alternative Energy, Monitoring, IoT.*

## 1. INTRODUCTION

Almost every sector of development requires electrical energy for the activities carried out. and it is very dependent on the source of electrical energy originating from state electricity company. Therefore, it has some impacts on the high amount of electricity production and causes high costs incurred.

Because of the necessary for electrical energy is high, conventional energy sources continue to decrease, humans are required to utilize energy sources that cannot be exhausted and can be renewable and environmentally friendly. Renewable energy is able to produce electrical energy by utilizing natural energy sources, one of which is sunlight.

The trend of using renewable energy continues to increase so that the concept of a smart grid system appears. Smart grid system is an intelligent energy network concept to meet the needs of electrical energy which is a primary human need in the present and future that has high level of flexibility, accessibility and efficiency. Smart grid monitors, regulates and manages electrical energy starting from the generation system to the use of loads in real time with the aim of increasing optimization in the use of renewable energy sources.

With a smart grid system that uses Internet of Things (IoT) technology, users can overcome limitations in monitoring and controlling because it can be done remotely. IoT is technology which is a technology or concept that can communicate between connected machines or through the internet network.

To facilitate monitoring and controlling the system, IoT technology is used so, it can monitor and control the load of the system, both AC loads and DC loads which can be monitored and controlled remotely. It can also monitor and regulate the use of the load system so that it can detects if there is a disturbance and it will be maintained to provide electrical energy to both AC load and DC load.

This paper proposes the application of alternative energy power plants at SMK Negeri 1 Indralaya Selatan. It is expected to be able to monitor and control voltage and power remotely the use of both, AC and DC load system and detect the disturbance of solar cell by using IoT technology so that it can be maintained to provide electricity.

## 2. LITERATURE REVIEW

### 2.1. Solar Power Plant

It is a power plant that utilizes sunlight by utilizing a solar panel to be used as electricity where the use of technology from this power plant is to convert photon energy sources from sunlight into electrical energy. This conversion occurs in photovoltaic modules consisting of photovoltaic cells. Solar cell components consist of solar module, solar charge controller, inverter and battery.

### 2.2. Smart Grid System

Smart grid system is a modern electrical energy network that can integrate the power grid intelligently with communication devices that support power generation and distribution networks to be more attractive, communicative, and of high quality. Smart grid monitors, regulates and manages electrical energy starting from the generation system to the use of loads in real time with the aim of increasing optimization in the use of renewable energy sources. This intelligent power grid manages all parts including the production, distribution, and consumption of electrical energy.

The smart grid system has several general characteristics, namely:

1. Allows the customer to monitor and regulate the supply and use of the load accordingly.
2. Monitoring and regulation of electrical energy is carried out in real time with the accuracy of delivering information and data up to 100%.
3. Allows automatic repair when a failure or damage occurs and isolates elements that fail or damage to minimize blackouts

### 2.3. Monitoring

Monitoring is a continue activity to collect data and measure the result towards planned goals. Monitoring will provide information on status and trends, where measurements and evaluations are carried out from time to time repeatedly. Monitoring is usually carried out for a specific purpose such as to check the process or condition of the evaluation effect for an object or to develop and maintain towards the achievement of management results. Several types of actions are managed continuously.

### 2.4. Internet of Things (IoT)

Internet of things is a concept where an object has the ability to transmit data by the internet network without any human to human or human to computer

interaction. Internet of things works by applying a programming command, where each command can produce an interaction between machines that are connected automatically and without being limited by long distances.

### 2.5. Node MCU ESP 32

In general, Node MCU is an IoT platform that is used through the development of Node MCU ESP8266. NodeMCU ESP8266 is a microcontroller module that designed with ESP8266 in it. ESP8266 serves for wifi network connectivity between the microcontroller and the wifi network. It uses the Lua programming language, but it can also use Arduino IDE for programming is a microcontroller that comes from the expressive system and the development of the ESP8266 where the it has functions for wifi network connectivity between the microcontroller and the existing wifi network while on ESP32 it is already there are wifi modules and bluetooth modules so that it supports to apply systems that use the internet of things.

The ports contained in the ESP 32 are as follows:

1. 18 ADC ports (Analog Digital Converter, functions as a converter of analog signals to digital)
2. 2 DAC ports (Digital Analog Converter, functions to convert digital signals to analog)
3. 16 PWM ports (Pulse Width Modulation) 4. 10 Touch Sensor
4. 2 Line UART interface ports
5. I2c, I2S, and SPI interface pins

## 3. RESEARCH METHODS

The overall design shows the concept and method of the system which consists of hardware design -includes mechanical and electronic design- and software design.

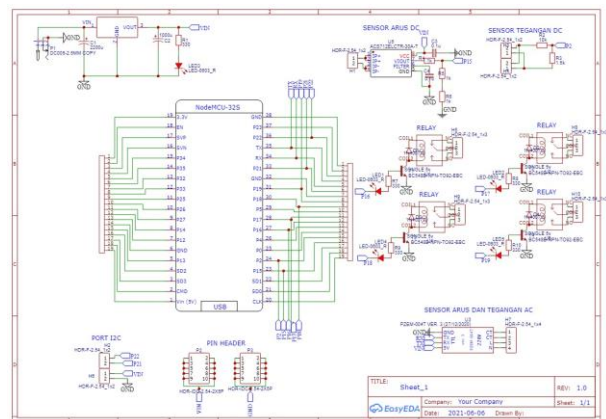

**Figure 1** Electronic Schematic Diagram

In the figure 1 is the entire circuit of this monitoring and control system consisting of ACS712 sensor, PZEM004T sensor, relay module, voltage divider, voltage sensor, ESP32, Port 12C for LCD which is combined into a whole series device.

**3.1 Block Diagram**

The explanation of the block diagram in the picture above, namely the value of the current and voltage sensors to measure the DC load will be read and sent and processed in the ESP32 Microcontroller and also the voltage and current values for measuring AC loads are also processed on the ESP32 and then will be sent to the Blynk application via the internet network. which will be displayed on the 20x4 LCD Screen. remote control on the Blynk application can be done to turn on or turn off electricity using a relay.

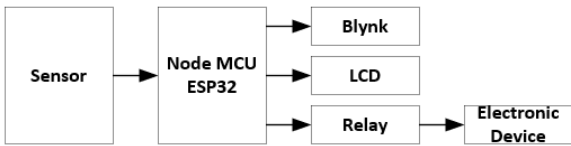

Figure 2 Block Diagram

**3.2 Blynk Display Design**

Blynk is designed for the Internet of Things with the aim of being able to control the system remotely, can display data sensors, can store data, and more. Blynk itself is an application that can be downloaded for free that works to control Arduino, Raspberry Pi and more by the Internet. This picture shows the appearance of Blynk.

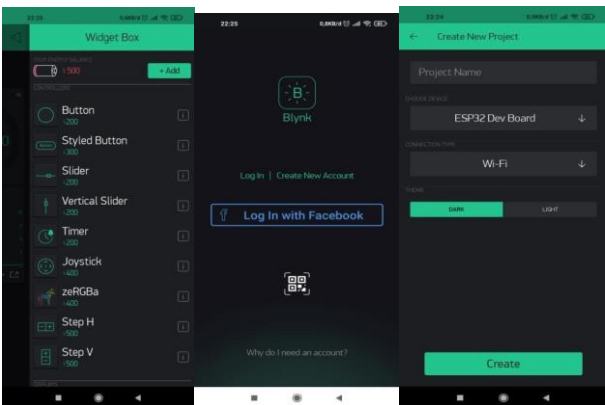

Figure 3 Blynk Display

**3.3 Monitoring System Flowchat**

In this monitoring section when the load is installed or when the system is given a load, both AC load and DC load, the current sensor and voltage sensor will read the value of the load and when the data has been read, the data or the data read will be displayed on the LCD and also in the Blynk app on smartphones.

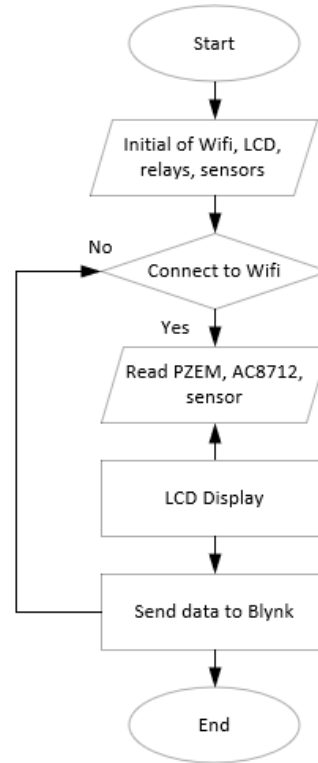

Figure 4 Flowchart

**4. RESULTS AND DISCUSSION**

**4.1. DC Load Testing**

The DC load voltage and current test is carried out at the test point where the test point is carried out at the output of the battery which is directly used by the DC load. This test is carried out using the ACS712 current sensor and voltage sensor where the results of the sensor readings will be read on the monitoring system that has been made. in the Blynk app.

This test is a comparison of reading the current and voltage values using a multi meter compared to the monitoring system that has been made in the blynk application. And in this test using 3 experiments with the first experiment using no load used and the second using a DC water pump and also DC lamp on the third try.

**Table 1.** DC Load Testing

DC Load	Voltage (V)			Current (A)			Power (Watt)			
	By Multimeter	By Monitoring	Error	By Multimeter	By Monitoring	Error	By Multimeter	By Monitoring	Error	
No load	23.8	23.8	0	0	0	0	0	0	0	
DC Water Pump	24.2	24	0.008	0.05	0.05	0	1.21	1.2	0.008	
DC 12 W Lamp	23.6	24	0.16	0.5	0.52	0.02	11.8	12.48	0.03	
Error Average (%)			0.008				0.007	0.012		

Based on table 1, the percentage error by comparing the measured power value on the multi meter and the value read on the monitoring system shows an error value of 0.008% when the load is a dc water pump while the error is 0.03% in the test using a 12 watts lamp where the average percentage error is obtained from the use of a load in the form of a dc water pump and a 12 watts dc lamp of 0.012 %.

#### 4.2. AC Load Testing

In testing the AC load current and voltage sensors, it is carried out at the test point where this test point is at the inverter output which directly uses the AC load. As for this test, using a multimeter to read the current and voltage on the AC load where the power being tested uses a calculation of the product of the current and voltage and the power factor. Where the power factor is obtained from the PZEM004T sensor reading, because the multimeter cannot read the value of the power factor.

In this test using a PZEM Sensor which can read the current, voltage, power and power factor values where the value read on this sensor will be sent to the monitoring that has been made in the blynk application. the AC load test is carried out to see the percentage of error by using the calculation of the percentage of error where the error or error value can be obtained from the calculation value - the measurement value divided by the calculation value

It can be seen that the results obtained from the first experiment until the fifth experiment resulted in a value of 0-18.9 W. In the load power test, it was obtained based on the product of the current and voltage calculations from the multimeter and in testing using the monitoring system on the blynk application, the value was 0- 18.4 W. For power error average percentage, the value shows of 0.064%.

#### 5. CONCLUSIONS

In the DC load power test with 3 trials with tests in the form of no-load power, water pump power and 10 watts lamp power, it was found that the percentage error or error was 0.12% with a sensor accuracy rate of 99.88%.

In testing the AC load power by experimenting 5 times with tests in the form of no-load power, water pump power, lamp power 10 watts, 5 watts and 7 watts it was found that the percentage error or error was 0.064 % with a sensor accuracy rate of 99.936%

For further development, it is possible to use various types of sensors so that they can be compared with this system. Then use a very stable internet network to ensure that the data that is read there is no delay in sensor readings and the monitoring system. And then it can use the other IoT media in monitoring other than smartphone.

**Table 2.** AC Load Testing

DC Load	Voltage (V)			Current (A)			Power (Watt)			
	By Multimeter	By Monitoring	Error	By Multimeter	By Monitoring	Error	By Multimeter	By Monitoring	Error	
No load	218	225	0.03	0	0	0	0	0	0	
AC 10W Lamp	218	224.7	0.03	0.07	0.08	0.014	8.73	9.7	0.11	
AC 5W Lamp	219	226.2	0.03	0.04	0.04	0	4.99	5.2	0.04	
AC 7W Lamp	219	224.1	0.023	0.05	0.06	0.2	6.24	7.2	0.15	
AC Water Pump	218	224.3	0.028	0.15	0.16	0.666	18.9	18.4	0.02	
Error Average (%)			0.027				0.176	0.064		

**REFERENCES**

- [1] David Hanes, Gonzalo Salgueiro, Rob Barton, "IoT Fundamentals: Networking Technologies, Protocols, and Use Cases for the Internet of Things", Cisco Press, 2017
- [2] Husu A.G., "Applications of renewable", Ed. Bibliotheca, ISBN: 978-606-772-187-4, Târgoviște, 2017
- [3] A. D. Pangestu, F. Ardianto, and B. Alfaresi, "Sistem Monitoring Beban Listrik Berbasis Arduino Nodemcu Esp8266," *J. Ampere*, vol. 4, no. 1, p. 187, 2019, doi: 10.31851/ampere.v4i1.2745.
- [4] N. Park and M. Kim, "Implementation of load management application system using smart grid privacy policy in energy management service environment," *Cluster Comput.*, vol. 17, pp. 653–664, 2014.M.