

The Effect of Satisfaction and Brand Connection to Brand Love

Welly Nailis^{1*}, Zakaria Wahab², Sulastri³, Muchsin Saggaff⁴, Suhartini Karim⁵,
Mohammad Eko Fitrianto⁶

¹Ph.D. student of Universitas Sriwijaya, Indonesia

^{2,3,5}Senior lecture, Universitas Sriwijaya, Indonesia

⁴Senior lecture, Universitas Bakrie

⁶Ph.D. student of Universitas Gadjah Mada, Indonesia

*Corresponding author. Email: wellynailis@unsri.ac.id

ABSTRACT

This study aims to examine the effect of brand satisfaction and brand connection on brand love. The survey method was used as a research strategy to examine the effect of these two variables. 100 people as research respondents participated through an online questionnaire. This study chose smartphone owners as a contextual element to explain the relationship between variables. Structural Equation Modelling (SEM) was employed using AMOS software to test the research hypothesis. The results showed that satisfaction ($\gamma=0,250$, $\text{sign}=0,000$) and brand connection ($\gamma=0,655$, $\text{sign}=0,000$) had significant effect on brand love. These findings have an impact on management implications that brand satisfaction and brand connection can make consumers love the brand. Limitations and suggestions for further research are discussed.

Keywords: *satisfaction, brand connection, brand love.*

1. BACKGROUND

In the brand management literature there is a relationship paradigm called customer-brand relationship. Fetscherin and Heinrich conducted a bibliographic study that found the following constructs of consumer relations with brands, namely: brand loyalty, brand trust, brand attachment, brand passion, brand romance, brand tribalism and brand love [1]. Brand love is a phenomenon experienced by a group of satisfied consumers. Brand love as a construct describes the affective feelings of a satisfied consumer group. Positive feelings from consumers towards the brand affect their evaluation and emotional reactions [2]. Brand love is the highest degree of emotional commitment and passion that individuals maintain with the brand, such as emotional bonds that occur beyond reason [3]. Building consumer's brand love is very important for academics and practitioners because a group of satisfied customers become loyal customers, thereby reducing some costs and also increasing some marketing activities [4].

Brand love comes from the topic of customer and brand relationships (customer - brand relationship). The brand relationship paradigm becomes a valuable explanation of brand loyalty, which explains the long-

term relationship between customers and brands. From this relationship, it is known that customers can fall in love with the brand. The concept of falling in love with a brand (brand love) was conceptualized by Albert [5] and Batra [2], and then measured by Ahuvia [3].

Brand love is also define as a degree of emotional attachment a satisfied consumer has to a specific commercial name [6]. Brand love exists when satisfaction exists [7]. Satisfaction is an important antecedence for brand love. The level of satisfaction creates a basis for the formation of brand love. Carroll and Ahuvia set out three differences between brand love and satisfaction: (1) satisfaction is generally conceptualized as a cognitive while brand love is affective. Satisfaction is considered the result of specific transactions at a given time – it is a mood that belongs to the past; (2) brand love is often the result of a long-term relationship of consumers with their brand; (3) finally, love implies the integration (or affective commitment) of the brand into the consumer's own identity, a characteristic that is not necessary in satisfaction. Integration will only occur when the individual's desire for the brand to reflect their identity is very high [3].

The others antecedent is brand connection. Carroll and Ahuvia confirmed identification with the brand as one of the antecedents in the development of love toward it and defined this feeling of identification as the consumer's perception of the degree of connection with the brand [3]. Martin et al proposed brand connection as one of the antecedents of brand love. They use football team fans as a context of brand love. Brand connection is how the fans connect with the brand and identify that they are becomes part of who they are [8].

Identification refers to the totality of individual thoughts and feelings that the consumers share with respect to themselves and a branded. Identity refers to the relevant characteristics and the experiences of an individual, the inter-relations between those characteristics, as well as the social functions and the self-regulating functions that they serve. They showed how the connection with a football brand is one of the main determinants of the intention to purchase the products of a sports team and entry to their events. The individuals make an effort to link themselves to social groups that are positively reflected in their self-perceptions [8]. This study aims to examine the effect of satisfaction and brand connection as antecedent variables of brand love.

2. LITERATURE REVIEW AND HYPOTHESIS DEVELOPMENT

Recent marketing literature shows that brand love is beyond a discussion about consumer satisfaction. Previously different levels of satisfaction became the basis for the emergence of consumers' love for the brand [3]. In addition, the connectedness between consumers and brands becomes important as the basis of brand love [8]. In brief, the relationship between variables will be discussed as follows.

2.1. Brand love

Brand love defined as a high degree of emotional commitment and passion that an individual maintains with a brand, i.e., an emotional bond that goes beyond reason [3]. Love changes the perceptions of people, defines their emotional boundaries and causes them to take risks and accept costs. Previous research suggests that people can attribute quasi-human characteristics to brands in the same way that they relate to other humans in the social context by developing such brand love [9]. Aggarwal (2004), to illustrate these cases, mentions that there are people who are fans of Volkswagen Beetle cars or Harley Davidson motorcycles, they can even name them or touch them with affection [10]. Recently, Christino et al. showed how this brand love develops among consumers with certain brands of smartphones [6]. On the other hand, Belk states that the motivation

behind this process is that consumers see their possessions or services, for example, a brand, as an extension of themselves and in the interest of maintaining such congruence they assign human qualities that people have or wish to have towards the generation of an ideal of themselves [11]. Overall, love is a global and abstract concept commonly defined as the subjective and holistic integration of previous thoughts, feelings and actions [12]. The term "brand love" could, however, is a complex term where academic research tries to clarify the confusion with other terms such as satisfaction, commitment or identification, commented on in the previous section. This is especially relevant within the field of marketing since the construct of brand love is relatively new to this field [13].

2.2. Satisfaction

The concept of customer satisfaction is one of the most important issues in marketing thought and practice because it is one of the most significant determinants of repeat sales, positive word-of-mouth, and consumer loyalty [14]. Customer satisfaction is the result of post-purchase evaluation, namely, if in the customer's opinion the performance of the product or service is better than expected, a high level of satisfaction results, and vice versa. Satisfaction implies the fulfilment condition of consumer expectations [15]. When the difference in the fulfillment of consumer expectations occurs, it creates a different level of consumer satisfaction. Different levels of satisfaction then underlie the emergence of love for the brand. Customers consider satisfaction with (product) experiences as an important predictor of future consumption outcomes [16].

Hypothesis 1: Satisfaction has a positive influence on brand love.

2.3. Brand connection

In a consumer-brand relationship, it is so important to examine the strength of the connection. The consumer should identify themselves as a part of a brand. Sirgy states identification refers to the totality of individual thoughts and feelings that the consumers share with respect to themselves and a branded item [17]. Identity refers to the relevant characteristics and the experiences of an individual, the inter-relations between those characteristics, as well as the social functions and the self-regulating functions that they serve [8]. Carroll and Ahuvia confirmed identification with the brand as one of the antecedents in the development of love toward it and defined this feeling of identification as the consumer's perception of the degree of connection with the brand [3]. Brand connection then becomes one of prominent antecedence of brand love. They are used as an extension of the actual self, as a result, the consumer may connect himself to a brand in the construction of his ideal-self

[18]. The consumers describe the object of their love in terms of characteristics which are similar to their own [6].

Hypothesis 2: Brand connection has a positive influence on brand love.

3. METHOD

This study uses a survey method. The population is the entire object that has the same characteristics understudy, while the sample is part of the population taken for generalization. The characteristics of the respondents involved in this study are the owners of electronic products, namely mobile phones for personal use with certain brands, who have used the product for at least 2 years or have purchased the same brand in that time period. Repeat purchases and duration of use are in accordance with the criteria and characteristics of the brand love construct, where new brand love will grow after consumers make repeat purchases and use them for a long time.

3.1. Sample and procedure

The sampling method used is non-probability sampling using judgmental sampling. The exact number of mobile phone owners in Indonesia is unknown, but based on data from the Ministry of Communication and Information, there are 240 million devices circulating in Indonesia [19], according to this number it is difficult to conduct probability sampling. However, to maintain the quality of the research (external validity aspect), the sample selection was carried out carefully by considering the research criteria. To meet the requirements of statistical testing, this study considers the adequacy of statistical calculations by taking 100 samples. This number is in accordance with the calculation of the number of constructs that are less than five, based on the multivariate research reference from Hair et al [20, h. 574].

3.2. Measurement

There are two independent variables and one dependent variable in this study. Brand love as a dependent variable define as a high degree of emotional commitment and passion that an individual maintains with a brand, i.e., an emotional bond that goes beyond reason [3]. The independent variables in this research is satisfaction and brand connection. Satisfaction define as the result of post-purchase evaluation, namely, if in the customer’s opinion the performance of the product or service is better than expected, a high level of satisfaction results, and vice versa [14]. Brand connection define as the consumer’s perception of the degree of connection with the brand [3]. All construct measure with interval scale using Likert five scale. Survey method employed to collect the data, all questions measured with Likert scale

(1: fully disagree; 5: fully agree) it contained 15 questions related to 3 constructs.

4. RESULT

The research results consist of several parts, namely: sample characteristics, reliability test, confirmatory factor analysis (CFA), and structural equation modeling (SEM). The sample characteristics contain two parts, namely demographic aspects and smartphone user characteristics. Construct test conduct with reliability test (Cronbach alpha) and confirmatory factor analysis for validity test. To test the relationship between constructs, structural equation modeling was employed using AMOS software.

4.1. Sample characteristics

According to table 1 (demographic aspect), most of the individuals responding to the questionnaire are female (53 percent) than male (47 percent), aged between 17 and 25 years of age (54 percent), and students 47 percent as their occupations.

Table 1. Demographic aspect

	F (%)
Gender	
Male	47 (47)
Female	53 (53)
Age	
17-25 years old	54 (54)
26-35 years old	14 (14)
36-45 years old	17 (17)
46-55 years old	14 (14)
More than 55 years old	1 (1)
Occupation	
Student	47 (47)
State worker	20 (20)
Private worker	21 (21)
Entrepreneur	12 (12)

Note: n=100

As a shown in table 2, we also add a few questions to confirm the smartphone user characteristics as a research context to explore their love to the brand. According to research descriptives, most of them use Samsung brand as their primary phone (29 percent), expected for functional benefit (96 percent), event price sometimes could be important and not (49 percent), but brand is more important 65 percent.

Table 2. Smartphone user characteristics

	F (%)
--	-------

Handphone's brand	
Oppo	22
Vivo	13
Samsung	29
Iphone	18
Xiaomi	15
Realme	3
Expected benefit	
Functional benetif (telephone call, internet, camera features, etc.)	96 (96)
Emotional benefit (prestige, cool, proud, etc.)	4 (4)
Price is important	
Yes	29 (29)
No	22 (22)
Couldbe "Yes" or "No"	49 (49)
Brand is important	
Yes	65 (65)
No	7 (7)
Couldbe "Yes" or "No"	28 (28)

Note: n=100

Table 5. Confirmatory factor analysis

Construct	Item	Component			Total	AVE	Square root of the AVE
		1	2	3			
Satisfaction	SAT1	0.770	-	-	4.150	.830	.911
	SAT2	0.864	-	-			
	SAT3	0.910	-	-			
	SAT4	0.854	-	-			
	SAT5	0.752	-	-			
Brand connection	BC1	-	0.786	-	4.001	.800	.895
	BC2	-	0.844	-			
	BC3	-	0.809	-			
	BC4	-	0.816	-			
	BC5	-	0.746	-			
Brand love	LOV1	-	-	0.771	3.782	.756	.870
	LOV2	-	-	0.709			
	LOV3	-	-	0.720			
	LOV4	-	-	0.786			
	LOV5	-	-	0.796			

Note: Kaiser-Meyer-Olkin Measure of Sampling Adequacy=0,935; Bartlett's Test of Sphericity (sign=0,000); n=100

According to table 5, all the constructs also presented convergent validity (Composed Reliability and Average variance extracted) with values within the limits proposed by the literature, which is 0.50 for AVE.

4.4. Hypothetical testing

After the analysis of dimensionability, reliability and validity of the con- structs, the nomologic validity of the

4.2. Reliability analysis

A reliability test intended to ensure the consistency of the data. The results of the reliability test are as a shown on table 3. All variable considered to reliable because has Cronbach alpha (α) above 0,6.

Table 3. Reliability analysis

Variable(s)	n of items	α	result
Satisfaction	5	0,935	Reliable
Brand connection	5	0,945	Reliable
Brand love	5	0,970	Reliable

Note: reseach data

4.3. Confirmatory factor analysis

According to table 4, all item show difference to other because has square root of the AVE higher than correlation coefficient compared with other variable.

Table 4. Validity discriminant analysis

	1	2	3
Satisfaction (1)	0.911	-	-
Brand connection (2)	0.540	0.895	-
Brand love (3)	0.647	0.838	0.870

Note: research data

model proposed was verified. The results found are summarized in Table 6.

Table 6. Hypothetical testing

	Estimate	S.E.	C.R.	Result
H1: LOV ← SAT	.250*	.074	3.366	Supported
H2: LOV ← BC	.655*	.070	9.347	Supported

Note: SAT=Satisfaction, BC=Brand Connection, LOV=Brand love; *Sign level < 0,05

According to table 6, satisfaction has significant influence on brand love ($\gamma=0,250$, $\text{sign}=0,000$). This result support the hypothesis 1: Satisfaction has a positive influence on brand love. Brand connection has similar positive significant influence on brand love ($\gamma=0,655$, $\text{sign}=0,000$). This result support the hypothesis 2: Brand connection has a positive influence on brand love.

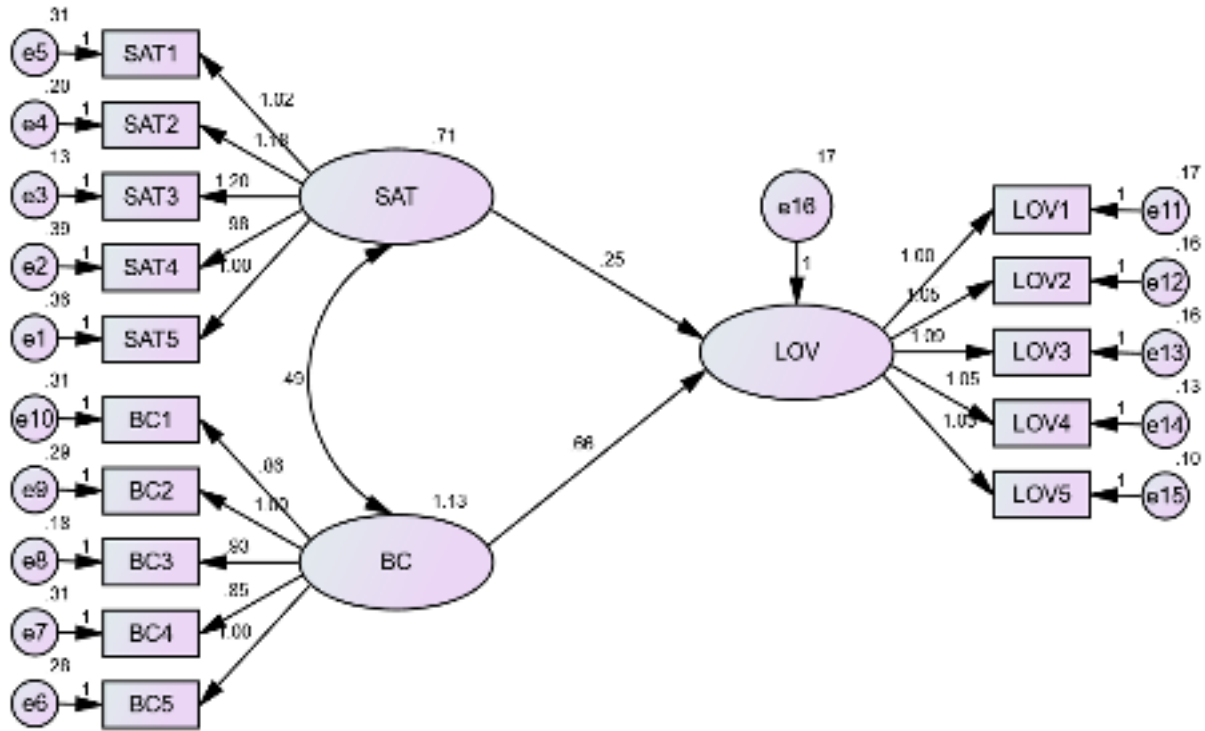

Figure 1. Structural equation modelling Brand Love

5. DISCUSSION

The main goals of this study is to examine the effect of satisfaction and brand connection as antecedent variables of brand love. Result shown both of hypothesis supported the prediction. Satisfaction and brand connection has significant positive influence on brand love. Theoretical implications can be made from the results of analysis of the relationship between the observed model’s variables. Satisfaction is an important antecedence for brand love. The level of satisfaction creates a basis for the formation of brand love has proved by result. In other side, brand connection to brand love has significant level higher than satisfaction has.

This research was expected, higher level of satisfaction and brand connection could be basis of brand love. In this context of research, higher level of satisfaction and brand connection from smartphone user, can influence to makes them more love the brand. This present finding correspondence with those of Martin et.

al. [8] , Christino et al. [6], and also Marinkovic and Kalinic [14].

The study findings also offer useful managerial implications. Results of the regression analysis from structural equation modeling, clearly show that brands must concern with consumer satisfaction and maintain consumer connection. Therefore, marketing campaigns must focus on customer satisfaction and improve consumer connections.

6. CONCLUSION

Satisfaction and brand connection is a prominent factor to brand love. Previously, because of brand love is the highest degree of emotional commitment and passion that individuals maintain with the brand, it is a good reason why a brand must has concern to the construct. Building consumer’s brand love is very important for academics and practitioners because a group of satisfied customers become loyal customers, thereby reducing some costs and also increasing some marketing activities.

7. LIMITATION

Our research is subject to a number of limitations that offer opportunities for future research. *First*, This study does not focus on measuring the strength of a brand-specific, so it is not yet clear how the level of satisfaction and brand connectedness can produce brand love. Further research is suggested to focus on examining one particular brand and measuring satisfaction and connectedness between consumers and brands. *Second*, self-administrative survey with non-probability sampling can arise external validity issues. We recommend measuring membership-based brand love for a particular brand. Membership in a brand can answer the issue of non-probability sampling and validate consumers who have a high commitment to a particular brand.

AUTHORS' CONTRIBUTIONS

The authors of the paper both meet the following conditions: 1) substantial contributions to conception and design, acquisition of data, or analysis and interpretation of data; 2) drafting the article or revising it critically for important intellectual content; and 3) read and approved the final manuscript to be published.

ACKNOWLEDGMENTS

This work was supported by grants from SATEKS scheme Universitas Sriwijaya 2021 (Grant number: 2738/UN9.FE/TU.SK/2021).

REFERENCES

- [1] M. Fetscherin dan D. Heinrich, 'Consumer brand relationships research: A bibliometric citation meta-analysis', *Journal of Business Research*, vol. 68, no. 2, h. 380–390, 2015.
- [2] R. Batra, A. Ahuvia, dan R. P. Bagozzi, 'Brand love', *Journal of Marketing*, vol. 76, no. 2, h. 1–16, 2012.
- [3] B. A. Carroll dan A. C. Ahuvia, 'Some antecedents and outcomes of brand love', *Market Lett*, vol. 17, h. 79–89, 2006.
- [4] J. L. Lastovicka dan N. J. Sirianni, 'Truly , Madly , Deeply : Consumers in the Throes of Material Possession Love', *Journal of Consumer Research*, vol. 38, no. 2, h. 323–342, 2011.
- [5] N. Albert dan D. Merunka, 'The role of brand love in consumer-brand relationships', *Journal of Consumer Marketing*, vol. 30, no. 3, h. 258–266, 2013.
- [6] J. Christino, T. Silva, L. R. Moura, dan L. H. Fonseca, 'Antecedents and Consequents of Brand Love in the Smartphone Market: An Extended Study of the Impact of Switching Cost', *Journal of Promotion Management*, vol. 26, no. 3, h. 301–321, 2020.
- [7] V. P. Gumparthi dan S. Patra, 'The Phenomenon of Brand Love : A Systematic Literature Review The Phenomenon of Brand Love : A Systematic', *Journal of Relationship Marketing*, vol. 19, no. 2, h. 93–130, 2020.
- [8] F. V. Martin, L. D. Toledo, dan P. Palos-Sanchez, 'How deep is your love? Brand love analysis applied to football teams', *International Journal of Sports Marketing and Sponsorship*, vol. 21, no. 4, h. 669–693, 2020.
- [9] D. Aaker, *Managing Brand Equity*. New York: The Free Press, 1991.
- [10] S. S. Aggarwal, 'Brand Ambassadors and their Impact on Consumer Behavior: A Case Study of Mobile Companies in India', *Indian Journal of Marketing*, vol. 39, no. 12, h. 3–8, 2009.
- [11] I. Jasmina, B. Stacey, dan K. Alicia, 'Names versus faces: examining spokesperson-based congruency effects in advertising', *European Journal of Marketing*, vol. 49, no. 1/2, h. 62–81, 2015.
- [12] B. Fehr, 'Prototype Analysis of the Concepts of Love and Commitment', *Journal of Personality and Social Psychology*, vol. 55, no. 4, h. 557–579, 1988.
- [13] L. Bergkvist dan T. Bech-larsen, 'Two studies of consequences and actionable antecedents of brand love', *Journal of Brand Management*, vol. 17, no. 7, h. 504–518, 2010.
- [14] V. Marinkovic dan Z. Kalinic, 'Antecedents of customer satisfaction in mobile commerce of customization', *Online Information Review*, vol. 41, no. 2, h. 138–154, 2017.
- [15] R. L. Oliver, 'Measurement and Evaluation of Satisfaction Processes in Retail Settings', *Journal of Retailing*, vol. 57, no. 3. h. 25–48, 1981.
- [16] A. Jessen dkk., 'The playground effect: How augmented reality drives creative customer engagement', *Journal of Business Research*, vol. 116, no. September 2019, h. 85–98, 2020.
- [17] M. J. Sirgy, 'Self-Concept in Consumer Behavior: A Critical Review', *Journal of Consumer Research*, vol. 9, no. 3, h. 287, 1982.
- [18] R. W. Belk, 'Possessions and the Extended Self', *Journal of Consumer Research*, vol. 15, no. 2, h. 139, 1988.
- [19] I. M. of I. Kominfo, 'Jumlah Pengguna Internet 2017 Meningkatkan, Kominfo Terus Lakukan Percepatan Pembangunan Broadband', *Kominfo*, 2018. [Online]. Tersedia di:

https://kominfo.go.id/content/detail/12640/siaran-pers-no-53hmkominfo022018-tentang-jumlah-pengguna-internet-2017-meningkat-kominfo-terus-lakukan-percepatan-pembangunan-broadband/0/siaran_pers.
[Diakses: 29-Mar-2019].

- [20] J. F. Hair, W. C. Black, B. J. Babin, dan R. E. Anderson, *Multivariate Data Analysis*, 7Th ed. London: Pearson Education Limited, 2014.