



Static Characteristic Analysis of Steel Clarification Tank

Zhuanding Gong^{1*}, Wanlin Zhang²

¹Gansu Water Conservancy Engineering Geology Construction Co., Ltd., Lanzhou 730030, China

²Gansu Road & Bridge Construction Group., Lanzhou 730030, China

*1136324263@qq.com

Abstract. With the development of China's economy and industrialization, the steel clarification tank has become an essential and important component in sewage treatment and chemical production, playing a crucial role in improving treatment efficiency and reducing costs. This paper studies the deformation of a steel clarification tank under different conditions, focusing on stress and displacement with varying wall thicknesses. The analysis shows that in dry conditions, the maximum stress occurs at the connection between the vertical and inclined walls, while in full water conditions, it occurs at the connection between the steel column and tank support. The maximum displacement always happens at the connection between the vertical and inclined panels, regardless of the presence of water. The steel clarification tank with an 8 mm wall thickness has the lowest stress but the largest displacement.

Keywords: Steel; Clarification tank; Statics characteristic; Analysis

1 Introduction

With the gradual improvement of China's economic strength and the rapid advancement of industrialization, the steel clarification tank has become an indispensable and important part of sewage treatment and chemical production. As an important energy reserve and treatment equipment, it can be used in sewage treatment plants to discharge mud and purify sewage. It not only saves labor, but also improves the production capacity of sewage treatment and greatly reduces costs. Therefore, the study of the clarification tank is not only very important for the safety of structures, but also has guiding significance for the more accurate design of disaster prevention.

Zhou [1] conducted finite element analysis on LNG tank walls, showing large bending moments under static loads. Jiang et al. [2] studied cyclic and axial stresses on tank walls. Eyas and Sukru [3] proposed a stiffness - flexibility matrix methodology, which was founded on the principles of thin shell theory. Yang et al. [4] derived buckling critical stress formulas for tank walls. Cheng et al. [5-6] studied sloshing effects in steel rectangular tanks and seismic responses in SF-type liquid-storage tanks. Meier [7] reviewed all types of water tanks, providing insights on design, construction, and maintenance.

© The Author(s) 2025

G. Zhao et al. (eds.), *Proceedings of the 2025 8th International Conference on Traffic Transportation and Civil Architecture (ICTCA 2025)*, Atlantis Highlights in Engineering 39,

https://doi.org/10.2991/978-94-6463-793-9_8

Thus, the tank in full water, water influence on the tank, the existing research is mainly on the reinforced concrete storage structure and steel rectangular storage tank, therefore, for the static response of steel clarification tank filled with water and anhydrous under the different wall thickness on the structure, static stress and displacement distribution of the tank will be analyzed, so as to provide some guidance and reference for similar engineering in the future.

2 Analytical Model

Fig. 1 illustrates that the steel clarification tank's tank body is fabricated from steel. The outer tank features a diameter of 11.50 m, while the inner tank measures 3.65 m in diameter. The overall height of the tank structure reaches 10.50 m. The main components include the guide plate, the reaction cylinder, the water collecting tank and the fender are steel plates. ADINA finite element software was used for modeling, and the element type was solid element.

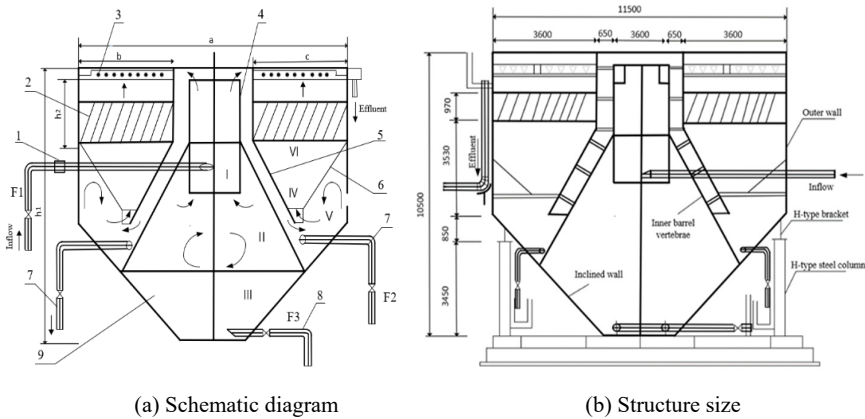

Fig. 1. Schematic diagram of the steel clarification tank

3 Parameter Settings

The parameters selected for this study are presented in Table 1. It is necessary to simulate the tank wall, inner barrel, cone, column section, support and bottom plate of the steel clarification tank. Then, two element groups of model shell and fluid are defined and the basic properties of materials are defined. To establish a three - dimensional finite element analysis model, the pool wall, inner barrel, cone, and bottom plate of the steel clarification tank were partitioned into shell units.

Table 1. Model parameters.

Parameter	Value
-----------	-------

Elastic modulus E/Pa	2.1×10^{11}
Poisson's ratio μ	0.3
Density $\rho/(kg/m^3)$	7800
Acceleration of gravity $g/(m/s^2)$	9.8

4 Results Analysis

4.1 Static Characteristics of Steel Clarification Tank Under Different Panel Thicknesses

In order to study the influence of the thickness of the wall plate on the clarification tank, it is assumed that the column section is H300mm × 300mm × 15mm × 15mm unchanged, and three different wall thicknesses of 8 mm, 10 mm and 12 mm are analyzed. In the case of no water inside and outside the tank, the stress calculation results of the clarification tank under different wall thicknesses are shown in Fig. 2.

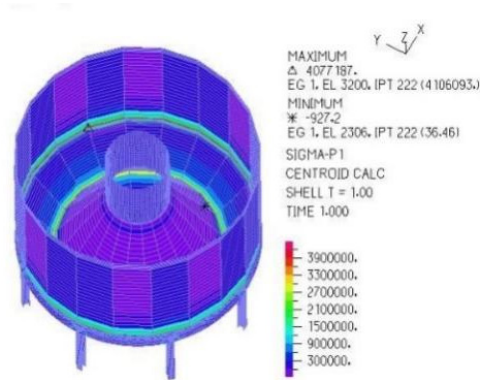

(a) 8 mm

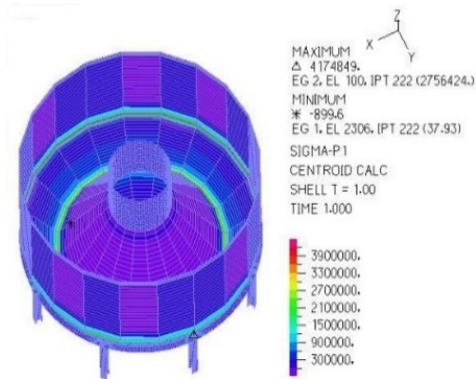

(b) 10 mm

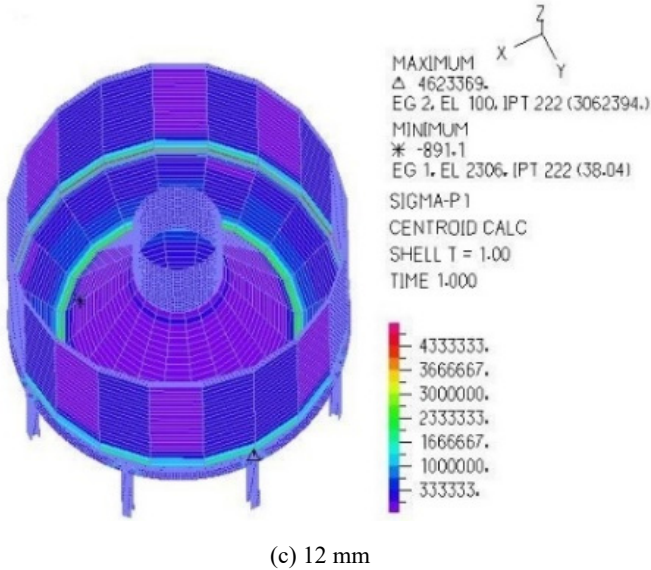
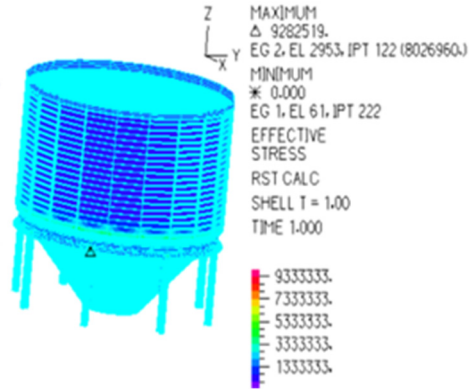

Fig. 2. Stress nephogram of clarification tank with different wall plate thicknesses under no water

It can be seen from Fig. 2 that the maximum stress of the steel clarification tank under the condition of anhydrous wall thickness of 8 mm is 4.077×10^6 Pa, and the maximum stress occurs at the connection between the vertical wall plate and the inclined wall plate of the tank. The maximum stress of the steel clarification tank with a wall thickness of 10 mm is 4.175×10^6 Pa, and the maximum stress occurs at the connection between the vertical wall and the inclined wall of the tank. The maximum stress of the clarifying tank under the thickness of 12 mm is 4.623×10^6 Pa, and the maximum stress occurs at the junction of the vertical wall and the inclined wall. By analyzing the steel clarification tank with wall thicknesses of 8 mm, 10 mm, and 12 mm under anhydrous conditions and comparing the corresponding stress nephograms, it is evident that the maximum stress values of the tank vary with different wall thicknesses in the anhydrous state. The peak stress is located at the junction between the vertical and oblique wall plates of the tank. Specifically, the steel clarification tank exhibits the lowest maximum stress when the wall thickness is 8 mm, while the highest maximum stress occurs when the wall thickness is 12 mm. This reveals that the wall thickness significantly impacts the stress distribution within the steel clarification tank.

The stress calculation results of the clarification tank under the different wall thickness are shown in Fig. 3.



(a) 8 mm

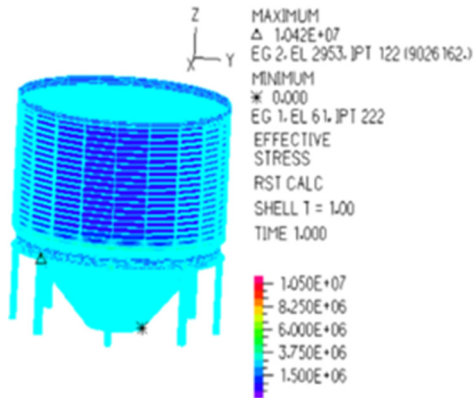

(b) 10 mm

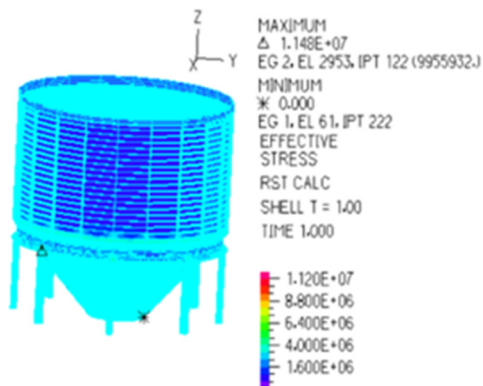

(c) 12 mm

Fig. 3. Stress nephogram of clarification tank with different column wall thickness in full water condition

Fig. 3 reveals that when the wall thickness of the steel clarification tank is 8 mm and it is full of water, the maximum stress reaches 9.283×10^6 Pa, occurring precisely at the junction of the steel column and the tank support. For a 10 mm - thick wall, the maximum stress of the tank amounts to 1.042×10^7 Pa, also located at the connection between the steel column and the tank support. When the wall thickness is 12 mm, the maximum stress is 1.148×10^7 Pa, again at the same connection point. By analyzing the tank with 8 - mm, 10 mm, and 12 mm wall thicknesses under full - water conditions and comparing their stress nephograms, it becomes evident that the stress levels of the steel clarification tank vary with different wall thicknesses. The peak stress consistently appears at the joint of the steel column and the tank support. Specifically, the minimum maximum stress occurs with an 8 mm wall plate, while the maximum maximum stress is associated with a 12 mm wall plate.

It can be seen from Fig.4 that the thickness of the wall plate has a great influence on the maximum stress of the steel clarification tank in full water condition. The thickness of the wall plate has little effect on the maximum stress of the steel clarification tank in the empty tank condition. It can be seen from the analysis of the nephogram that the stress of the clarification tank increases with the increase of the thickness of the wall plate in the anhydrous condition, and the stress of the clarification tank increases with the increase of the thickness of the wall plate in the full water condition, and the change of the maximum stress in the full water condition is more obvious.

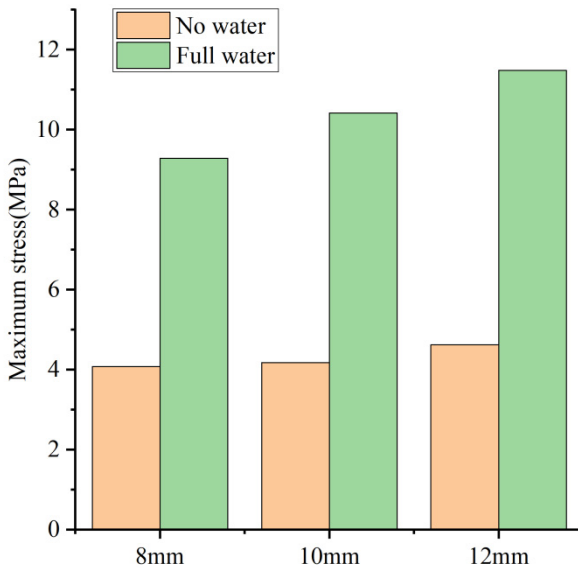
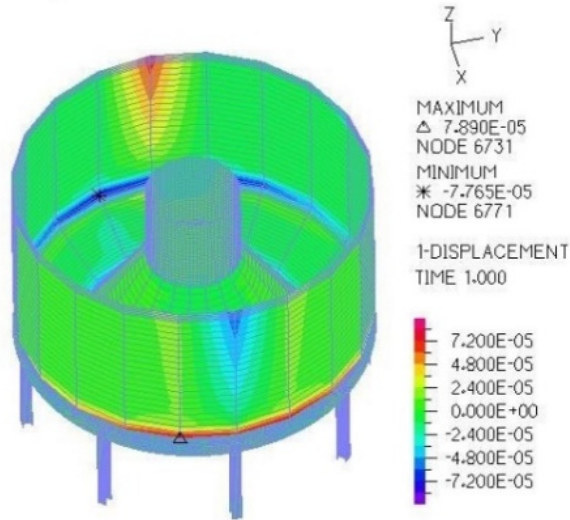

Fig. 4. Stress effect of water on clarification tank

4.2 Displacement of the Clarification Tank Where Both The Internal and External Tanks Have No Water

In the case of no water inside or outside the tank, the calculation results of the displacement of the clarification tank under different wall thicknesses are shown in Fig. 5.



(a) 8 mm

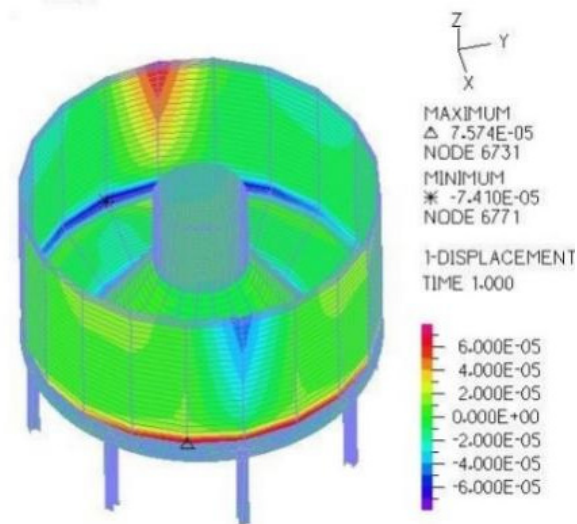

(b) 10 mm

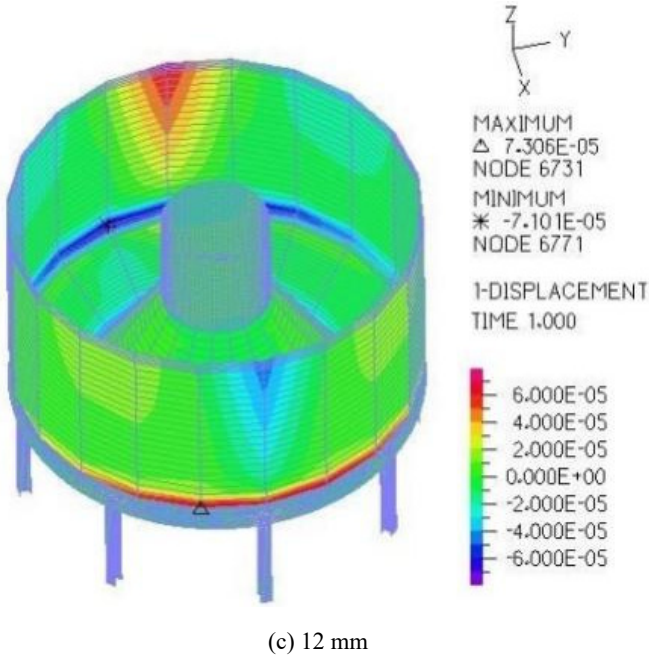
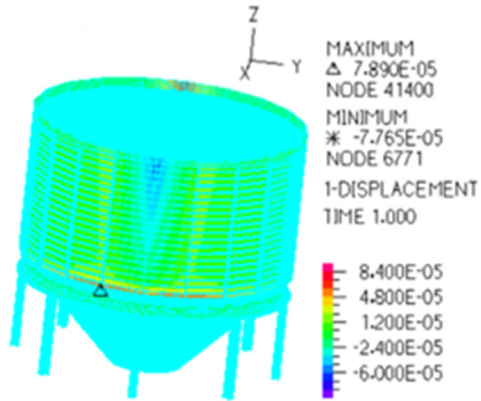

Fig. 5. Displacement nephogram of the anhydrous condition clarified pool

Fig. 5 demonstrates that when the wall thickness of the clarification tank is 8 mm under anhydrous conditions, the maximum displacement value reaches 7.89×10^{-2} mm, occurring precisely at the connection between the vertical and inclined wall plates of the tank. With a 10 mm - thick wall, the maximum displacement of the tank is 7.574×10^{-2} mm, also located at the junction of the vertical and inclined walls. For a 12 - mm - thick wall, the maximum displacement measures 7.306×10^{-2} mm, again at the same connection point. By analyzing the steel clarification tank with wall thicknesses of 8 mm, 10 mm, and 12 mm under anhydrous conditions and comparing the corresponding displacement nephograms, it becomes evident that the maximum displacement values vary depending on the wall thickness. The peak displacement consistently appears at the connection between the vertical and inclined wall plates of the tank. Specifically, the steel clarification tank exhibits the largest maximum displacement with an 8 mm thick wall plate and the smallest with a 12 mm thick wall plate. This indicates that the wall thickness significantly influences the maximum displacement of the steel clarification tank; notably, an increase in wall thickness leads to a decrease in the maximum displacement.

The calculation results of the displacement of the clarification tank under the thickness of the wall plate are shown in Fig. 6.



(a) 8 mm

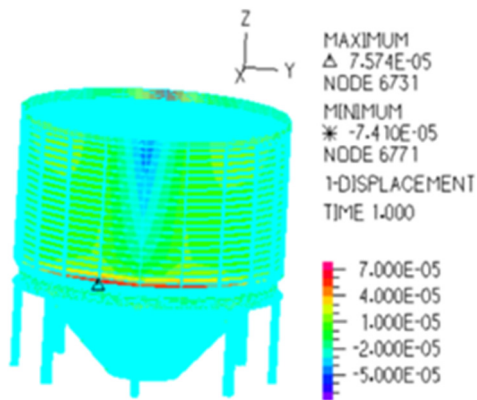

(b) 10 mm

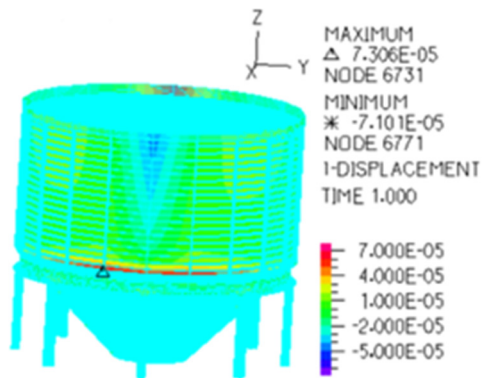

(c) 12 mm

Fig. 6. Displacement nephogram of the clarification tank with water

It can be seen from Fig. 6 that the maximum displacement of the steel clarification tank under the condition of full water with a wall thickness of 8 mm is 7.89×10^{-2} mm, and the maximum displacement occurs at the connection between the vertical wall plate and the inclined wall plate of the tank. The maximum displacement of the steel clarification tank with the wall thickness of 10 mm is 7.574×10^{-2} mm, and the maximum displacement occurs at the connection between the vertical wall and the inclined wall. The maximum displacement of the clarification tank is 7.306×10^{-2} mm when the wall thickness is 12 mm, and the maximum displacement occurs at the junction of the vertical wall and the inclined wall. Through the analysis of the steel clarification tank under the condition of full water with 8 mm, 10 mm and 12 mm wall thickness, and the comparison of the displacement nephogram of the steel clarification tank, it can be seen that the maximum displacement of the steel clarification tank under different wall thickness is different under the condition of full water.

The peak displacement is situated at the junction of the tank's vertical and oblique wall plates. Among them, the steel clarification tank with an 8 mm - thick wall plate exhibits the largest maximum displacement, while the one with a 12 mm thick wall plate has the smallest maximum displacement. This indicates that the wall plate thickness significantly impacts the maximum displacement of the steel clarification tank; specifically, as the wall plate thickness increases, the maximum displacement of the tank decreases. Fig. 7 illustrates the effect of water on stress.

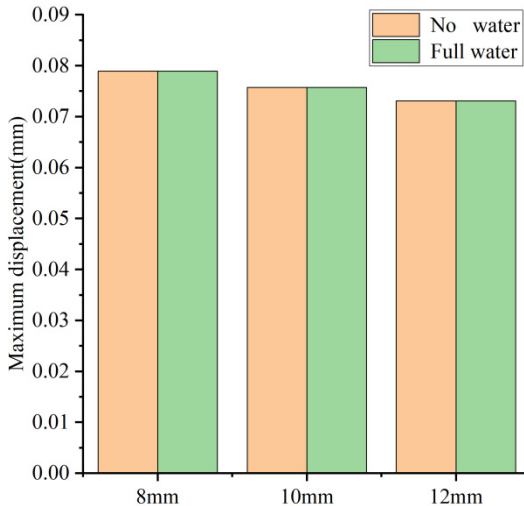

Fig. 7. Effect of water in the clarification tank on displacement

As can be seen from Fig. 7, the absence of the tank has little effect on the maximum displacement of the tank. Through the displacement analysis of the clarification tank in the case of different wall thicknesses, no water and full water, it is concluded that the size of the displacement and the location of the clarification tank without water and full

water is not related to whether there is liquid in the tank, and increasing the wall thickness has an effect on the displacement value of the clarification tank.

5 Conclusions

(1)The maximum stress in the clarification tank increases with the wall thickness. In the dry condition, the maximum stress occurs at the connection between the vertical and inclined walls, while in the full water condition, it occurs at the connection between the steel column and the tank support

(2)As the wall thickness increases, the maximum displacement decreases. In both the dry and full water conditions, the maximum displacement is largest at a wall thickness of 8 mm and smallest at 12 mm.

(3)The stress in the full water condition is significantly higher than in the dry condition, but the presence of water has a minimal effect on the displacement.

References

1. Zhou B. "Finite element analysis of LNG outer tank under the cases of static load LNG". *Si-chuan Building Materials* 40(2), 57-58 (2014).
2. Jiang L.Q., Song H.Y., Zhang Y.F., et al. "Finite element analysis and test verification of extra large vertical steel tank structure". *Cryogenic Construction Technology* 7(16), 65-68 (2020).
3. Azzuni E., Guzey S. "Comparison of the shell design methods for cylindrical liquid storage tanks". *Engineering Structures* 101, 621-630 (2015).
4. Yang L.C., Chen Z.P., Cao G.W., et al. "An analytical formula for elastic-plastic instability of large oil storage tanks". *International Journal of Pressure Vessels and Piping* 101, 72-80 (2013).
5. Cheng X.S., Hu L.K., Yu D.P., et al. "Dynamic analysis on a buried horizontal double-layer SF-type liquid-storage tank by finite element method". *Electronic Journal of Structural Engineering* 18(2), 139-150 (2018).
6. Cheng X.S., Chen J., Luo B.B. "Reduced sloshing effect in steel tanks". *International Journal of Steel Structures* 22(5), 1474-1496 (2022).
7. Meier S.W. "Steel Water Storage Tanks: Design, Construction, Maintenance, and Repair". *Recommendation: Revisions Required. Journal - American Water Works Association*, (2010).

Open Access This chapter is licensed under the terms of the Creative Commons Attribution-NonCommercial 4.0 International License (<http://creativecommons.org/licenses/by-nc/4.0/>), which permits any noncommercial use, sharing, adaptation, distribution and reproduction in any medium or format, as long as you give appropriate credit to the original author(s) and the source, provide a link to the Creative Commons license and indicate if changes were made.

The images or other third party material in this chapter are included in the chapter's Creative Commons license, unless indicated otherwise in a credit line to the material. If material is not included in the chapter's Creative Commons license and your intended use is not permitted by statutory regulation or exceeds the permitted use, you will need to obtain permission directly from the copyright holder.

