



# Research Progress on Power Decoupling Control for Grid-Connected Inverters

Haoying Kuang

College of Electrical and Information Engineering, GuangDong Baiyun University, Guangzhou, 510405, China

hy.Kuang@outlook.com

**Abstract.** With the continuous expansion of global energy demand and increasing integration of renewable energy into power grids, maintaining grid stability has become significantly more challenging. As the essential interface connecting renewable energy sources to the grid, grid-connected inverters critically depend on advanced power decoupling technology to effectively mitigate intermittent power fluctuations inherent in renewable generation and ensure reliable system operation. This paper conducts a systematic investigation into recent progress in power decoupling control methodologies for grid-connected inverters. The study classifies existing decoupling approaches according to their underlying control architectures, followed by a rigorous comparative evaluation of their respective advantages and technical limitations. Through this analytical process, several critical shortcomings in contemporary power decoupling solutions are identified. In response to these limitations, the research proposes a series of targeted technical enhancements and innovative improvement strategies. The study establishes theoretical foundations while providing actionable technological references for future developments in decoupling technology. By resolving existing limitations in stability, efficiency, and implementation complexity, this work contributes substantively to next-generation grid-interactive power conversion systems.

**Keywords:** Renewable Energy, Power Grids, Grid-Connected Inverter, Power Decoupling.

## 1 Introduction

Rapid economic growth has intensified the conflict between rising energy demand and the limitations of traditional fossil fuels, including supply shortages and environmental pollution. This situation makes the transition to clean, low-carbon energy development an imperative. Within this energy transition, electricity plays a dominant role in the energy system. Therefore, building new power systems with renewable energy as the mainstay is essential. This shift is both a necessary requirement for the transformation of the energy and power sectors and a critical pathway to achieving China's dual carbon goals.

Grid-connected inverters, serving as the critical interface between renewable energy generation and AC power grids, are the core equipment of modern power systems. Their reliability is vital to grid stability, while their topologies and control schemes directly determine power quality and transmission efficiency in grid-connected systems. In conventional single-phase grid-connected inverters, the instantaneous power imbalance between the DC input side and AC output side generates double-line-frequency ( $2\omega$ ) ripple power, which induces second-order harmonic voltage/current on the DC bus. This ripple adversely affects system reliability and stability. Taking photovoltaic (PV) systems as an example, the  $2\omega$  ripple causes the PV panel's operating point to deviate from the maximum power point (MPP), reducing power generation efficiency. For three-phase grid-connected inverters, the  $120^\circ$  phase difference between phases theoretically ensures balanced instantaneous power under ideal symmetric conditions, eliminating power ripple. However, in practical applications, nonlinear loads, grid voltage sags, and harmonic disturbances can still introduce low-frequency ripple components. To address these ripple issues, power decoupling techniques have been developed [1-3].

Power decoupling, as a control strategy enabling independent regulation of active and reactive power, has become a standard feature in modern grid-connected inverters and is critical for grid stability under high-penetration renewable integration. In microgrids, it allows distributed generation inverters to dynamically allocate power based on real-time demand, enhancing system stability and disturbance resistance. During islanding operations, it maintains frequency/voltage stability to ensure a reliable power supply for critical loads. Within distributed generation systems, this technology improves renewable energy utilization by facilitating maximum power point tracking (MPPT) through active power control, while reducing losses via flexible reactive power management, thereby boosting overall system efficiency [4].

This research focuses on power decoupling technologies in grid-connected inverters. Firstly, it systematically reviews recent advancements in the field, categorizing existing decoupling techniques into two primary development paths: topology optimization and control strategy improvements. Subsequently, the fundamental principles, advantages, and limitations of each decoupling approach are thoroughly analyzed. Finally, targeted enhancement strategies are proposed to address current performance and adaptability limitations, providing valuable insights for future optimized inverter design and control methodologies.

## 2 Principles of Power Decoupling

Current power decoupling technologies primarily fall into two categories: passive power decoupling and active power decoupling. Passive power decoupling operates without additional power switching components by utilizing energy storage elements to absorb pulsating power. In practical applications, this is typically achieved through either the parallel connection of large electrolytic capacitors on the inverter's DC bus or the implementation of LC resonant circuits, both of which absorb ripple power to

achieve instantaneous power balance between the AC output and DC input sides of the inverter.

Active power decoupling utilizes additional power switching components to dynamically regulate energy storage elements. Through dedicated decoupling control strategies, it actively absorbs and releases pulsating power. This method relies on both decoupling circuits and control algorithms to manage energy exchange in decoupling capacitors. Maintaining dynamic balance during power fluctuations significantly enhances decoupling accuracy and system stability.

### 3 Classification of Power Decoupling Techniques

#### 3.1 Passive Power Decoupling

Passive power decoupling is a simple and commonly used decoupling technique that typically does not require any control strategies. It usually involves adding large capacitors on the DC-link to absorb the pulsating power. Alternatively, an LC resonant circuit can be added, where the circuit parameters are designed to effectively suppress the ripple on the DC-link. This approach also helps reduce the value of the electrolytic capacitor on the DC-link.

#### 3.2 Active Power Decoupling

**Virtual Impedance Decoupling.** The core concept of virtual impedance decoupling is impedance reconstruction. It injects virtual impedance into the control loop, causing the inverter output to exhibit a high reactance ratio, simulating the reactive-dominant characteristics of a high-voltage power grid. In the dq coordinate system, the inductive impedance results in the active power being primarily controlled by the q-axis current, while the reactive power is controlled by the d-axis current, achieving P-Q decoupling. Virtual impedance decoupling is a commonly used power decoupling method in grid-connected inverters, especially in applications based on virtual synchronous generators (VSG) [5]. After introducing virtual impedance, the simplified equivalent circuit of a grid-connected VSG is shown in Fig. 1. Based on this equivalent circuit, a power expression is established, linearized to obtain a small-signal model, from which the decoupling condition (i.e., power coupling term coefficient equals zero) can be derived. Subsequently, a negative feedback mechanism is introduced, and a PI controller is used to dynamically adjust the virtual resistance based on the output voltage deviation to achieve power decoupling.

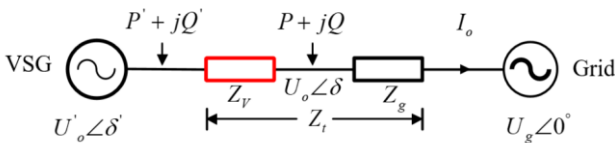

**Fig. 1.** Simplified equivalent circuit of a grid-connected virtual synchronous generator based on virtual impedance [5].

**Model Predictive Control (MPC).** Model Predictive Control (MPC) is an advanced control strategy that relies on mathematical models. It uses historical data and the current system state to predict future behavior, optimizing control decisions in real-time to achieve the best performance. MPC can be categorized into two types: Continuous Control Set MPC (CCS-MPC) and Finite Control Set MPC (FCS-MPC). In CCS-MPC, the controller output is continuous, such as drive voltage or duty cycle. In contrast, FCS-MPC focuses on the finite switching states of power devices. It predicts the system response for each state and calculates performance indices to select the optimal switching state. The core elements of MPC include predictive modeling, rolling optimization, and feedback correction.

MPC predicts the future state of the system based on the system model and generates optimal control strategies through optimization algorithms, enabling precise and independent control of active and reactive power. In contrast, traditional APD control uses a PI+PR structure, where the parameters are interdependent and difficult to coordinate. This leads to inaccuracies in capacitor voltage, affecting ripple suppression. To address this issue, some researchers have proposed a power decoupling control strategy based on predicting the input current of the APD circuit. By replacing traditional PI and PR controllers with Model Predictive Control (MPC), the method simplifies the parameter design and tuning process while improving current tracking and ripple suppression performance. This approach constructs a predictive model for the input current  $i_d$  of the APD circuit to enable real-time control of  $i_d$ . It can be embedded into grid-connected control systems to replace the current inner loop in the traditional double-loop structure, thereby enhancing the overall system control performance [6] [7].

Fig. 2 depicts a cascaded topology integrating a front-stage Buck-Boost DC/DC converter and a rear-stage full-bridge DC/AC inverter. Powered by photovoltaic (PV) output, the front-stage Buck-Boost circuit comprises a decoupling capacitor  $C_d$ , an energy storage inductor  $L_d$ , and switches  $S_1/S_2$ . The intermediate DC bus utilizes filter capacitor  $C_b$  to suppress high-frequency switching ripples, while the rear-stage full-bridge inverter ( $S_3-S_6$ ) with output filter inductor  $L_f$  delivers AC power. Employing Integrated Current-Constrained Cycle-by-Cycle Model Predictive Control (IC-CCS-MPC), this system maintains constant input current  $i_{in}$ , ensures average input power  $P_{in}$  matches DC bus average power, and enables collaborative low-frequency ripple buffering via passive components:  $C_d$  (voltage buffering) and  $L_d$  (current energy storage).

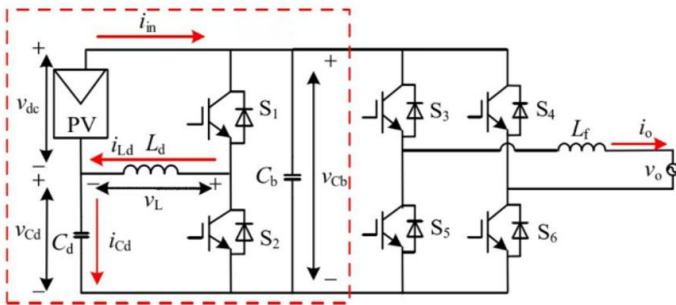

Fig. 2. Model Predictive Control topology [7].

**Adaptive Power Decoupling.** Adaptive power decoupling technology dynamically adjusts control parameters based on system operating conditions and environmental changes, enabling higher efficiency and stability. Its core mechanism utilizes real-time feedback and algorithmic optimization to autonomously adapt to system parameter variations, eliminating dependency on fixed parameter tuning.

Under unbalanced load conditions, grid-connected inverter power decoupling control faces limitations in managing grid voltage fluctuations, where suboptimal selection of proportional coefficients ( $K_p$ )—whether excessively large or small—degrades control precision. To overcome this, a genetic algorithm (GA) optimizes  $K_p$  within the power decoupling framework through the following procedure: after initializing GA parameters (population size and maximum generations), encoding  $K_p$  values to generate an initial population of proportional coefficients, and evaluating fitness scores for each  $K_p$  set, evolutionary operations—including parent selection based on fitness, crossover, and mutation—produce new populations. This cycle repeats until reaching the maximum generations, terminating with the output of optimal  $K_p$ . This GA-optimized decoupling control significantly enhances dynamic response speed and steady-state accuracy under unbalanced loads [8].

The implementation employs a dual-loop power controller with proportional coefficients to achieve power decoupling control in grid-connected inverters, while a genetic algorithm (GA) optimization is utilized to enhance the decoupling performance.

**Feedforward Power Compensation.** Model Predictive Direct Power Control (MPDPC) utilizes a single objective function to regulate both active and reactive power. When abrupt changes occur in one power component (e.g., active power step change), it dominates the objective function, causing degraded dynamic performance in the other component (e.g., reactive power). This transient power coupling during power step changes compromises inverter transient stability. To address this, feedforward power compensation acts as a reference regulator that injects a compensatory signal into the reactive power reference channel during active-power-induced coupling events, thereby achieving effective decoupling [9] [10].

## 4 Technology Comparison

### 4.1 Comparison of Advantages and Disadvantages

Passive power decoupling utilizing parallel-connected large electrolytic capacitors offers straightforward implementation and high reliability, but suffers from excessive capacitor volume and lifetime mismatch with PV systems. Although LC resonant circuits provide superior performance compared to standalone capacitors, they introduce significant physical size constraints and remain vulnerable to parameter drift induced by temperature variations and component aging.

Active power decoupling technologies are categorized into four primary approaches: virtual impedance decoupling, model predictive control, adaptive power decoupling, and feedforward power compensation.

**Virtual Impedance Decoupling.** Adaptive power decoupling offers strong self-tuning capabilities, dynamically optimizing control parameters (e.g., proportional coefficients) to accommodate system parameter variations. However, its reliance on intelligent optimization methods like genetic algorithms for parameter tuning involves substantial iterative computations. This results in higher computational complexity, particularly in large search spaces where slowed convergence may compromise real-time control performance.

**Model Predictive Control.** MPC enables multi-variable co-optimization with rapid dynamic response capabilities, making it suitable for nonlinear systems. Its primary limitation lies in strong model dependency—control performance degrades significantly under model mismatch conditions. Additionally, MPC requires online optimization calculations within each control cycle. When handling long prediction horizons or complex system models, substantial computational loads arise, increasing hardware requirements and implementation costs.

**Adaptive Power Decoupling.** Virtual impedance decoupling simplifies system architecture and reduces costs by introducing virtual inductive/resistive components within control algorithms, eliminating additional hardware. However, the inductive virtual impedance exhibits high impedance to high-frequency harmonics. Under conditions of significant harmonic distortion at the load side, this may exacerbate output voltage distortion, thereby amplifying system harmonic issues.

**Feedforward Power Compensation.** Feedforward power compensation achieves rapid response through disturbance prediction, enabling proactive compensation that enhances system dynamic performance. However, its applicability is limited to measurable disturbances detectable in real-time. For undetectable disturbances, it proves ineffective and typically requires integration with complementary control strategies for performance improvement. Furthermore, control accuracy remains highly dependent on system model precision.

The above content can be summarized as shown in Table 1.

**Table 1.** Comparative Analysis of Active Decoupling Techniques.

Technique	Advantages	Disadvantages
Virtual Impedance Decoupling	Hardware-free implementation Flexible system characteristic adjustment	Harmonic amplification
Model Predictive Control (MPC)	Achieves high-efficiency dynamic response via rolling optimization	Performance is model-dependent and requires high-precision modeling
Adaptive Power Decoupling	Automatically adjusts parameters based on system variations	Substantial computational burden due to extensive iterative calculations in GA optimization

Feedforward Power Compensation	Preemptive disturbance compensation	Undetectable disturbance vulnerability
--------------------------------	-------------------------------------	--

**4.2 Active Power Decoupling: Performance Dimensions and Technical Improvements**

Furthermore, this paper compares active decoupling technologies across four performance dimensions: complexity, reliability, response speed, and harmonic suppression. Results are summarized in Table 2. Both MPC and adaptive power decoupling exhibit significantly higher complexity and moderate reliability due to computationally intensive implementations. However, like feedforward compensation, they achieve rapid response speeds through real-time parameter adjustment. Regarding harmonic suppression, virtual impedance decoupling—essentially an impedance emulation technique—may amplify harmonics due to sensitivity to control accuracy, system interactions, and parameter design. The other three techniques demonstrate superior harmonic suppression capabilities.

**Table 2.** Performance Comparison of Active Decoupling Techniques

Technique	Complexity	Reliability	Response Speed	Harmonic Suppression
Virtual Impedance Decoupling	Low	High	Medium	Moderate
Model Predictive Control (MPC)	High	Moderate	Fast	Excellent
Adaptive Power Decoupling	Low	High	Fast	Excellent
Feedforward Power Compensation	High	Moderate	Fast	Excellent

In summary, adaptive decoupling and MPC exhibit high computational complexity yet hold significant improvement potential through machine learning and model simplification. Virtual impedance and feedforward compensation offer simpler implementation but require solutions for harmonic amplification and sensing accuracy limitations. To address these constraints, three enhancement strategies are proposed.

**Hybrid Strategy Exploration.** Virtual impedance decoupling faces limitations in harmonic amplification. To address this, a hybrid control strategy (virtual impedance + MPC) is proposed. MPC predicts future system states and suppresses harmonic currents/voltages via rolling optimization, counteracting harmonics potentially amplified by virtual impedance. Simultaneously, while virtual impedance typically relies on fixed-parameter implementations, integrating MPC’s real-time responsiveness enhances system robustness under dynamic operating conditions.

**AI Algorithm Integration.** Both adaptive decoupling and MPC incur substantial computational burdens for real-time control, with MPC particularly vulnerable to model inaccuracies. To overcome these limitations, reinforcement learning (RL) leverages policy networks to directly learn decoupling rules, thereby eliminating iterative parameter tuning and reducing computational overhead. Meanwhile, neural networks build data-driven models from system input–output data, effectively capturing intrinsic dynamics. Such models can autonomously adapt to system uncertainties and variations, reducing reliance on precise mathematical formulations while enhancing control accuracy [11].

**Hardware Innovation.** Feedforward compensation provides preemptive disturbance correction but faces limitations in undetectable disturbance zones and model-dependent accuracy. To overcome these constraints, next-generation sensors can be developed to enhance disturbance detection capabilities and sensing precision, ultimately improving compensation accuracy.

## 5 Conclusion

As the critical interface between renewable energy systems and the grid, grid-connected inverters significantly impact grid stability. However, inherent structural characteristics and unbalanced operating conditions—such as asymmetrical loads or grid voltage imbalances—generate power ripples that threaten grid stability. This necessitates power decoupling technologies to achieve independent control of active and reactive power.

This paper reviews current power decoupling technologies for grid-connected inverters, presenting application cases for each method alongside comparative analysis. In practical implementation, all decoupling techniques exhibit distinct trade-offs requiring careful selection based on specific operational scenarios. Nevertheless, existing approaches still face significant limitations. To address these challenges, we propose three improvement pathways to guide future research and optimization of power decoupling in grid-connected inverters.

**Acknowledgments.** This work was supported by the 2025 Special Fund for Scientific and Technological Innovation Strategy of Guangdong Province (University Student Science and Technology Innovation Cultivation Program) under Grant No. pdjh2025bc260.

## References

1. Wai, R., J., Wang, Y.: Power decoupling strategy for single-phase grid-connected inverter under weak power grid. In: 2018 3rd International Conference on Intelligent Green Building and Smart Grid (IGBSG), pp. 1–4. IEEE, Yilan, Taiwan (2018).
2. Tárraga, A., S., Molina, G., A., De, J., E., Villarejo, J.: Voltage ripple in three-phase unidirectional resonant converter for CHB PV inverter under nonunity power factor operation.

- IEEE Journal of Emerging and Selected Topics in Power Electronics 12(2), 1859–1874 (2024).
3. Li, D., Jiang, C., Chen, M., et al.: Overview of power decoupling technologies in photovoltaic grid-connected micro-inverters. *Journal of Power Sources* 2, 57–61+71 (2012).
  4. Zahraoui, Y., Bouhanik, A., Zidane, T., E., K., Campana, P., E., Mekhilef, S.: Grid-forming technologies for resilient renewable energy integration into power systems: a review. In: 2024 IEEE International Conference on Smart Systems and Technologies (SST), pp. 191–196. IEEE, Osijek, Croatia (2024).
  5. Li, G., Liu, Z., Wang, Q.: Dynamic virtual resistive power decoupling control strategy for Virtual Synchronous Generators. In: 2025 IEEE International Conference on Industrial Technology (ICIT), pp. 1–6. IEEE, Wuhan, China (2025).
  6. Guo, Y., Liu, M., Fang, X., Li, Z., Zhang, X.: Model predictive control for three-phase PWM rectifier with active power decoupling circuit under unbalanced grid voltages. In: 2019 IEEE International Power Electronics Conference (IPEC-Hiroshima), pp. 1–6. IEEE, Hiroshima, Japan (2019).
  7. Cheng, W., Mao, M.Q., Wang, H.J., et al.: Continuous current control integrated with model predictive power decoupling control for a new type of single-phase photovoltaic inverter. *Proceedings of the Chinese Society for Electrical Engineering* 43(24), 9655–9668 (2023).
  8. Dong, Y., Liu, P., Zhao, X.: Power decoupling control method for grid-connected inverters under unbalanced loads. *Chinese Journal of Electron Devices* 47(02), 404–409 (2024).
  9. Yan, L., Deng, X., Zhao, Z., et al.: VSG power decoupling control strategy based on adaptive feedforward compensation. *Power System Protection and Control* 52(24), 64–73 (2024).
  10. Wen, T., Zou, X., Guo, X., Zhu, D., Peng, L., Wang, X.F.: Feedforward compensation control for virtual synchronous generator to improve power decoupling capability. In: 2019 14th IEEE Conference on Industrial Electronics and Applications (ICIEA), pp. 2528–2533. IEEE, Xi'an, China (2019).
  11. Zhu, J., Lin, G., Dai, N.: Enhancing power decoupling control of grid-connected inverters through data-driven parameter optimization. *IEEE Transactions on Smart Grid* 15(4), 3456–3467 (2024).

**Open Access** This chapter is licensed under the terms of the Creative Commons Attribution-NonCommercial 4.0 International License (<http://creativecommons.org/licenses/by-nc/4.0/>), which permits any noncommercial use, sharing, adaptation, distribution and reproduction in any medium or format, as long as you give appropriate credit to the original author(s) and the source, provide a link to the Creative Commons license and indicate if changes were made.

The images or other third party material in this chapter are included in the chapter's Creative Commons license, unless indicated otherwise in a credit line to the material. If material is not included in the chapter's Creative Commons license and your intended use is not permitted by statutory regulation or exceeds the permitted use, you will need to obtain permission directly from the copyright holder.

