



# Research Progress in Bidirectional DC-DC Converter Topologies

Sitong Liu

College of Electrical and Information Engineering, Guangdong Baiyun University, Guangzhou 510405, China

LIU\_EE2027@outlook.com

**Abstract.** Bidirectional DC/DC converters, serving as essential devices for bidirectional energy flow in the field of power electronics, can effectively transfer energy while regulating voltage levels. Nowadays, with the vigorous emergence and rapid development of various fields such as new energy and electric vehicle technology, more stringent performance requirements have been imposed on bidirectional DC-DC converters. On the one hand, their topological structures are becoming increasingly complex, with many new architectures continuously emerging, such as multilevel and hybrid resonant types; on the other hand, the applicable scenarios for bidirectional DC-DC converters are also continually expanding and becoming more widespread. Against this background, this paper categorizes and briefly describes several common bidirectional DC/DC converter topologies, compares and analyzes their main characteristics and application scenarios based on their current status, summarizes the advantages and disadvantages of these topologies, as well as current improvements and optimization research conducted by scholars on some existing topologies, thereby providing valuable references for engineering application and practice.

**Keywords:** Bidirectional DC/DC Converter, Topologies, New energy.

## 1 Introduction

With the increasing severity of climate change and the crisis of traditional energy sources, environmental pollution has become more pronounced, drawing growing attention to the need for sustainable energy. Under the dual-carbon goals, the application fields of bidirectional DC-DC converters have expanded from traditional industries to widespread use in electric vehicles, aerospace power systems, battery management for energy storage systems, renewable energy grid integration, distributed energy systems, microgrids, and other areas. Effectively improving the efficiency and reliability of bidirectional energy flow in converters has become a critical research topic in the field of power electronics.

Bidirectional DC-DC converters are power electronic devices capable of bidirectional energy transfer between two DC power sources while providing voltage

regulation. In the field of electric vehicles, these include battery chargers with half-bridge LLC series resonant converters for improved power factor, as well as wide-range, high-voltage-gain bidirectional DC-DC converters designed for V2G (Vehicle-to-Grid) and G2V (Grid-to-Vehicle) applications in hybrid electric vehicle charging systems [1-2]. For satellite power systems, distributed power architectures incorporating solar panels and bidirectional DC-DC converters are employed to reduce size and weight. Notably, integrated three-port converters combining interleaved buck-boost circuits with dual-active-bridge (DAB) circuits, featuring three-switch legs, achieve current ripple reduction and wide-range zero-voltage switching [3-4]. In renewable energy applications, multipoint clamped bidirectional DC-DC converters have been developed to integrate renewable sources into dual-terminal DC grids [5]. Building upon conventional full-bridge dual-active-bridge resonant converters, CLLC resonant converter-based bidirectional battery chargers have been successfully implemented, effectively reducing circulating currents in resonant tanks and transformers while lowering MOSFET losses [6]. Furthermore, the adoption of high-efficiency wide-bandgap semiconductor devices has enabled the development of optimized bidirectional DC-DC converters for microgrid applications, resulting in reduced losses and enhanced switching performance [7]. Previous research demonstrates that bidirectional DC-DC converters exhibit diverse topologies and functional variations across different application domains.

Given the growing importance of bidirectional DC-DC converters in power electronic systems, this paper systematically analyzes their topologies by classifying them into two major categories. First, several typical non-isolated bidirectional converter topologies and their fundamental operating principles are introduced. Building upon current research status, the main technical characteristics and application scenarios of various structures are analyzed, with their advantages, disadvantages, and differences systematically summarized and compared. Second, the discussion focuses on isolated converter topologies, which are further subdivided into Pulse Width Modulation (PWM) converters and resonant converters based on their voltage regulation mechanisms. The operational characteristics and application orientations of each type are analyzed respectively. Finally, the paper summarizes research work conducted by scholars on these two categories of topologies, with particular emphasis on introducing the structural advantages and applicable ranges of typical innovative topologies. This provides both a theoretical foundation and technical references for the future design and optimization of novel bidirectional converter topologies.

## **2 Classification of Bidirectional DC-DC Converters**

Bidirectional DC/DC converters are developed from their unidirectional counterparts and can be categorized into two main types based on electrical isolation between high-voltage and low-voltage sides: non-isolated and isolated converters. Each category further comprises various sub-types with distinct characteristics and application scenarios. The classification is illustrated in Fig. 1.

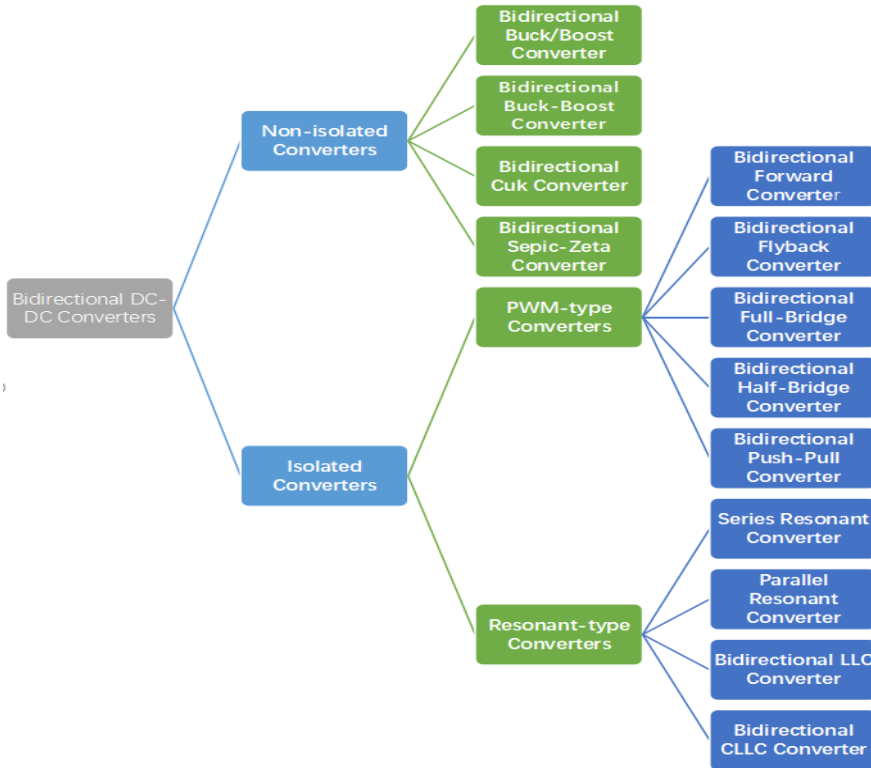

Fig. 1. Topology Classification Diagram.

### 3 Non-isolated Bidirectional DC-DC Converter Topologies

#### 3.1 Bidirectional Buck/Boost Converter

The bidirectional Buck/Boost converter is constructed based on either unidirectional Buck converters or unidirectional Boost converters. It can operate in three modes: boost, buck, and transition states. This converter features a simple topology with fewer components, low control difficulty, and high conversion efficiency. However, to achieve bidirectional power flow, constraints such as symmetrical topology and bidirectional voltage-blocking capability of switches must be introduced. These requirements compromise the wide voltage conversion range capability of unidirectional circuits, resulting in a relatively small input-output voltage conversion ratio. Additionally, it exhibits a relatively large current ripple and it is only applicable in scenarios with low power requirements and no need for electrical isolation.

### 3.2 Bidirectional Buck-Boost Converter

The converter is formed by connecting power switches in antiparallel to a unidirectional Buck-Boost converter. Its two switching transistors operate in complementary conduction modes. When current flows from  $V_1$  to  $V_2$ , the output voltage follows  $V_{out}=V_{in} \cdot D/(1-D)$ . Compared to bidirectional Buck/Boost converters, this topology features a simpler structure and a wider voltage regulation range through unidirectional duty cycle control. However, the absence of inductors at both input and output ports results in significant current ripple. The switching devices must withstand the sum of input and output voltages, leading to high voltage stress, thus limiting their application to low-power scenarios. Furthermore, the partial-power bidirectional DC-DC converter based on traditional bidirectional Buck-Boost topology only needs to process a portion of the system power. This design enhances power processing efficiency and improves overall system operational efficiency [8].

### 3.3 Bidirectional Cuk Converter

The Cuk topology is formed by connecting two unidirectional Cuk converters in series. During forward power transfer, switch  $S_1$  turns on while  $S_2$  remains off, enabling energy flow from left to right with the voltage relationship  $V_{out}=-V_{in} \cdot D/(1-D)$ . Conversely, during reverse power transfer, energy flows from right to left following  $V_{in}=-V_{out} \cdot D'/(1-D')$ . Where  $D$  and  $D'$  represent the duty cycles of the main switches during forward and reverse operations, respectively

This symmetrical topology provides bidirectional buck-boost capability. With inductors on both input and output sides, it effectively reduces current ripple while maintaining continuous output current, enabling higher power delivery. The switching devices experience relatively low current and voltage stress, though the output current remains somewhat fluctuating. Moreover, implementing linear PI control allows for a stable converter output, which not only enhances system safety but also extends battery lifespan [9].

### 3.4 Bidirectional Sepic- Zeta Converter

The bidirectional DC-DC converter formed by combining Zeta or SEPIC topologies features identical circuit structures, and since both unidirectional Zeta and SEPIC converters maintain the same input-output voltage polarity, it is referred to as a bidirectional Sepic-Zeta converter. During forward power transfer, its operation is equivalent to a Zeta converter through switch control; during reverse transfer, it behaves as a SEPIC converter.

This topology requires a larger number of passive components, resulting in lower power density. The output capacitance is typically higher than that of Buck/Boost converters, and due to discontinuous input or output current, it exhibits significant current ripple, necessitating additional external filtering. Moreover, its energy transfer efficiency is relatively low, making it more suitable for low-power applications.

Fig. 2 summarizes the characteristics of non-isolated topologies. To address the high voltage and current stress on the switches, additional MOSFETs and inductors

can be integrated on the low-voltage side, while series-connected capacitors can be utilized to supply the high-voltage side, thereby reducing switching current stress.

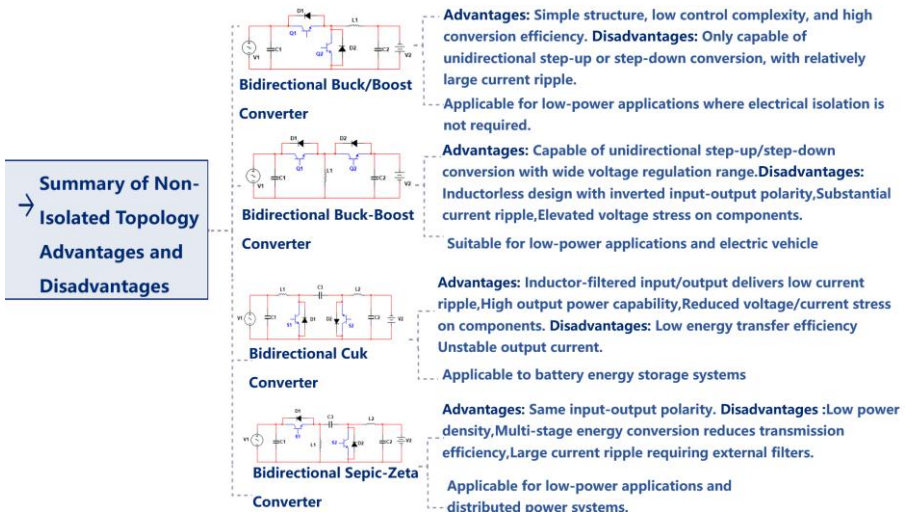

Fig. 2. Comparative analysis of non-isolated topologies' advantages and disadvantages.

## 4 Isolated Bidirectional DC-DC Converter Topologies

For PWM-based bidirectional DC-DC converters, pulse width modulation is employed to regulate the average output voltage, current, or power by adjusting the switching devices' duty cycle, thereby enabling wide-range voltage gain adjustment. The mature application of PWM control ICs and power devices makes this converter type particularly effective in protecting overcurrent, overvoltage, and overtemperature conditions. Furthermore, the PWM signal can be seamlessly integrated with digital controllers to achieve real-time regulation with fast dynamic response. Alternatively, resonant converters operate on a fundamentally different principle by incorporating resonant networks to achieve soft-switching characteristics, which dramatically reduce switching losses.

### 4.1 Research on PWM-Based Bidirectional DC-DC Converter Topologies

**Bidirectional Flyback Converter.** The bidirectional flyback converter is constructed by adding an antiparallel diode to the primary-side power switch and an antiparallel power switch to the secondary-side diode of a unidirectional flyback converter. In forward operation mode (left-to-right energy transfer), the primary switch Q1 is PWM-controlled while switch Q2 remains in the off state. The reverse operation mode follows the opposite principle.

This circuit exhibits several inherent limitations: the switches endure significant voltage/current stress, and hard switching operation leads to substantial switching losses. However, its advantages, including minimal component count, symmetrical topology, and low cost, make it widely applicable for low-power voltage conversion scenarios. Research has demonstrated potential solutions: forming resonant tanks with capacitors and leakage inductance to mitigate voltage/current stress, and employing active clamping techniques to achieve soft switching - though these approaches still present certain technical compromises.

**Bidirectional Forward Converter.** The bidirectional forward converter can operate in three modes: forward power transfer, reverse power transfer, and alternating transfer modes. In the alternating transfer mode, the converter maintains continuous current operation, which effectively reduces switch turn-on losses and eliminates current spikes associated with hard-switching. This converter features simple working principles and is particularly suitable for small-to-medium power applications. However, its transformer operates with unidirectional excitation, resulting in relatively low utilization efficiency. The magnetic core's unilateral magnetization limits the transformer's power handling capability and contributes to higher core losses compared to bidirectional excitation topologies.

**Bidirectional Push-Pull Converter.** Building upon the operational principles of both flyback and forward converters, researchers have developed the bidirectional push-pull converter. When properly designed with optimized output inductance, this topology maintains continuous current conduction in both forward and reverse power transfer modes, effectively eliminating current surges during mode transitions and reducing electromagnetic interference (EMI). Through phase-shift control implementation, all switching devices achieve zero-voltage switching (ZVS), significantly improving conversion efficiency. While cost-effective, this architecture subjects the power switches to substantial voltage stress - a limitation shared with bidirectional flyback DC-DC converters that constrains component selection. These characteristics position the push-pull converter as particularly suitable for medium-voltage and medium-power applications where moderate voltage stress can be accommodated.

**Bidirectional Half-Bridge and Full-Bridge Converters.** The half-bridge bidirectional DC-DC converter controls the switching transistors' turn-on and turn-off operations, enabling two operational modes through energy storage and release in the inductor. In boost mode, where energy flows from the low-voltage side to the high-voltage side, switch Q2 is turned on while Q1 remains off. Conversely, in buck mode, where energy flows from the high-voltage side to the low-voltage side, the switching states of Q1 and Q2 are reversed compared to the boost mode. This topology is suitable for medium-power applications.

The bidirectional full-bridge converter is constructed by replacing all diodes in the secondary side of a unidirectional full-bridge converter with reverse-parallel

connected power switches. Although this topology has a more complex structure and requires more components, leading to increased product size and cost, it exhibits lower voltage and current stress on the switching devices, making it more adaptable to high-voltage and high-current environments.

Fig. 3 summarizes the advantages and disadvantages of PWM converter topologies. To address the issues of unidirectional excitation and low utilization efficiency in transformers, improvements can be made in two main directions: First, by introducing flux balance control, where real-time monitoring and compensation of flux imbalance in the control strategy can prevent bias magnetization and additional losses caused by unidirectional excitation. Second, by adopting symmetrical PWM drive, ensuring strictly symmetrical duty cycles for the upper and lower bridge arms in the primary side during drive pulse design, thereby effectively suppressing DC components from entering the transformer core. In full-bridge converter topologies, this approach not only prevents core saturation and additional thermal losses but also enhances energy transfer efficiency and long-term system stability.

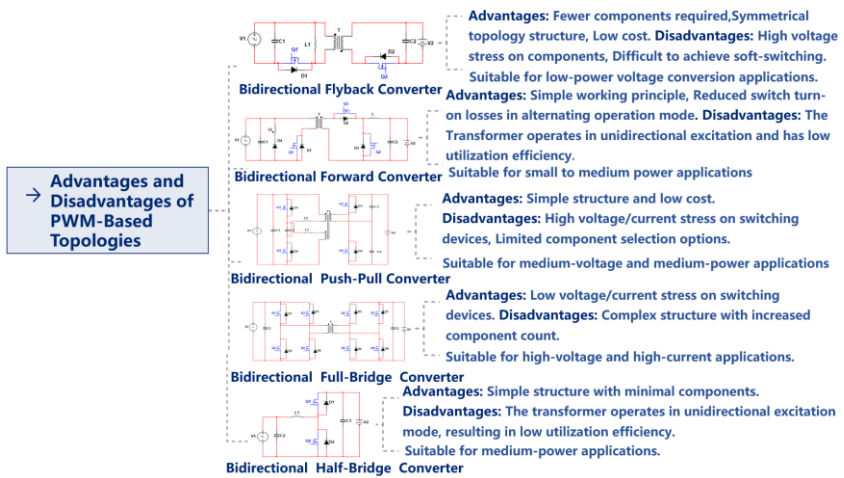

Fig. 3. Summary of Advantages and Disadvantages of PWM-based Topologies.

### 4.2 Research on Resonant DC Converter Topologies

Compared with PWM-based soft-switching techniques, resonant soft-switching technology can not only maintain the ZVS (Zero-Voltage Switching) characteristics of switching devices but also achieve ZCS (Zero-Current Switching) for rectifier-side power components, making it more suitable for high-frequency and high-power conversion applications [10].

Resonant converters are typically classified into second-order, third-order, and higher-order resonant circuits based on the number of passive components involved in resonance. Second-order resonant circuits are primarily represented by the Series Resonant Circuit (SRC) and Parallel Resonant Circuit (PRC), while third-order resonant circuits are exemplified by the LLC topology. Higher-order resonant circuits,

though relatively complex in structure, also include excellent solutions such as LCLC and LCLCL configurations.

**Bidirectional Series Resonant and Parallel Resonant Converters.** The series resonant converter represents a fundamental resonant topology where operation above the resonant frequency enables zero-voltage switching (ZVS), while operation below facilitates zero-current switching (ZCS). When the operating frequency deviates significantly from the resonant frequency, the voltage gain progressively decreases. Consequently, pulse frequency modulation is typically employed to regulate the control voltage and maintain ZVS operation.

This converter exhibits inherent gain limitations, with neither forward nor reverse normalized voltage gain capable of exceeding unity ( $M \leq 1$ ). The corresponding circuit schematic is presented in Fig. 4.

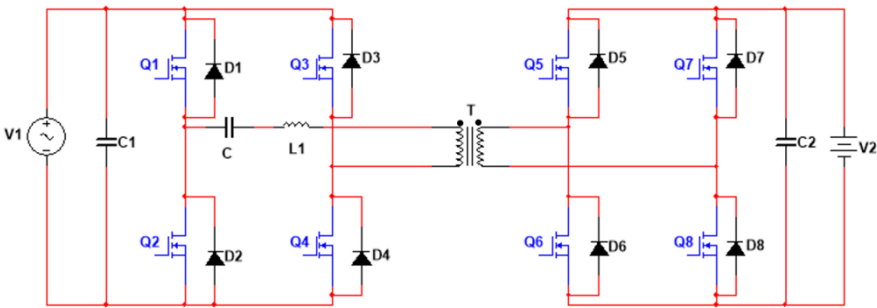

Fig. 4. Series Resonant Converter Topology.

The basic resonant structure of the parallel resonant converter (PRC) is similar to that of the series resonant converter (SRC), where zero-voltage switching (ZVS) can be achieved when the operating frequency exceeds the resonant frequency. However, unlike the SRC, the PRC's normalized voltage gain can exceed 1.

The parallel resonant converter exhibits significant circulating currents and generates higher turn-off currents at elevated input voltages, which adversely affect efficiency improvement. Consequently, this topology is suitable for scenarios where high efficiency is not a critical requirement. The corresponding circuit schematic is shown in Fig. 5.

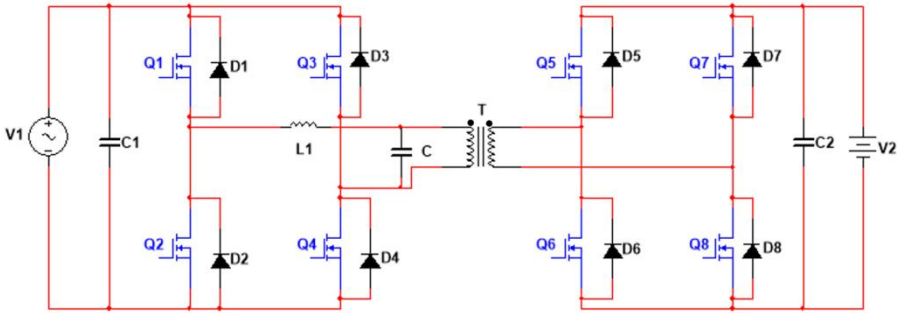

Fig. 5. Parallel Resonant Converter Topology.

**Bidirectional LLC Resonant DC-DC Converter.** As shown in Fig. 6, this converter combines the advantages of both SRC and PRC, achieving ZVS and ZCS for the switches. When the switching frequency is lower than the resonant frequency, the voltage gain exhibits PRC-like characteristics with a normalized gain greater than 1; Conversely, it exhibits characteristics of SRC with a normalized gain of less than 1.

This feature allows the LLC resonant converter to regulate voltage gain through frequency control. Moreover, the LLC converter can ensure the achievement of ZVS across the entire load range and can improve converter efficiency [10].

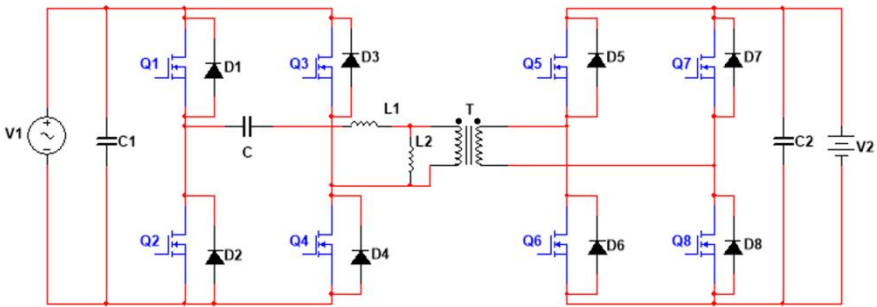

Fig. 6. Bidirectional LLC Resonant Converter.

When the LLC converter operates in reverse mode, its circuit structure inherently behaves as a Series Resonant Converter (SRC). This results in a reverse normalized voltage gain that can only be adjusted below 1 ( $M < 1$ ), which fails to meet the voltage fluctuation requirements of battery systems.

**Bidirectional CLLC Resonant DC-DC Converter.** Similarly based on the LLC topology, the addition of an extra resonant capacitor on the transformer's secondary side forms the CLLC structure, as shown in Fig. 7. This configuration also achieves ZVS and ZCS characteristics while enhancing circuit symmetry, thereby obtaining a wider range of bidirectional voltage gain that compensates for the LLC's gain

limitations and achieves excellent operational efficiency. These advantages have made it a research focus among scholars and enabled its application in scenarios such as high-frequency isolation in DC power grids and bidirectional charging/discharging for electric vehicles.

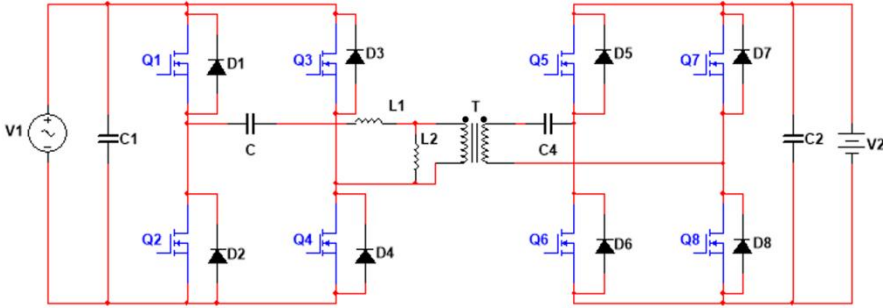

Fig. 7. Bidirectional CLLC Resonant Converter Topology.

For resonant DC-DC converters, improvements can be made in the following aspects: First, expanding the soft-switching operating range to enhance high-efficiency operation capability under different load conditions; second, optimizing the parameter design of the resonant network to reduce dependence on precise matching, thereby improving system adaptability and stability; third, introducing better control strategies to address the poor dynamic response during wide-range voltage regulation, shortening adjustment time and suppressing overshoot; fourth, optimizing circuit layout design and employing effective filtering techniques and shielding methods to effectively reduce electromagnetic interference.

## 5 Conclusion

This paper systematically classifies bidirectional DC-DC converters and conducts a comprehensive comparison and analysis of their topological characteristics and application domains. Non-isolated topologies, with their inherent advantages of structural simplicity and low cost, have been widely adopted in medium-low voltage and low-power scenarios. Through the integration of soft-switching techniques (e.g., ZVS/ZCS) and modular design approaches, these converters continue to push efficiency boundaries. Isolated topologies dominate high-voltage and high-power applications, where phase-shift control and active clamping technologies are routinely employed to effectively reduce voltage stress on switching devices while meeting high-frequency operation requirements. These converters have become critical components for bidirectional energy transfer, extensively implemented in electric vehicle battery management systems, renewable energy integration, distributed energy systems, and microgrid applications. The evolutionary trajectory of bidirectional DC-DC converter topologies is focused on four core objectives: high efficiency, high power density, wide operational adaptability, and enhanced

reliability. Current research and development efforts continue to optimize these key performance parameters through advanced topological innovations and control strategy improvements.

With the widespread adoption of wide-band gap semiconductor devices (SiC/GaN), topological designs are accelerating their evolution toward high-frequency and integrated solutions, where device-topology co-optimization breaks through traditional loss limitations. Simultaneously, intelligent control strategies and customized topologies are emerging as key research priorities to address the diverse requirements of different application scenarios, laying a robust foundation for the comprehensive deployment of bidirectional DC-DC converters.

**Acknowledgments.** This thesis was financially supported by the "2025 Special Fund for Science and Technology Innovation Strategy of Guangdong Province (Cultivation of College Students' Scientific and Technological Innovation)" (Project No.: pdjh2025bc260).

## References

1. Shahzad, M., I., Iqbal, S., Taib, S., Masri, S.: Design of a PEV battery charger with high power factor using half-bridge LLC-SRC operating at resonance frequency. In: IEEE International Conference on Control System, Computing and Engineering, pp. 424-429. IEEE, Penang, Malaysia (2015).
2. Kauluri, S., Damarla, I., Swathi, G.: Implementation of bi-directional converter for V2G and G2V hybrid EV chargers. In: 2nd International Conference on Cyber Physical Systems, Power Electronics and Electric Vehicles, pp. 1-6. IEEE, Hyderabad, India (2024).
3. Nakamura, S., Iwasa, M., Nakahara, M.: Cooperative control of power system with battery and solar cell for a satellite. In: International Conference on Renewable Energy Research and Applications, pp. 1-5. IEEE, Nagasaki, Japan (2012).
4. Huang, L., Zhang, D., Shi, K., Gu, R.: A novel three-port DC-DC converter with wide input Voltage Range for Satellite Application. IEEE Transactions on Industrial Electronics, 1-11 Early Access (2025).
5. Yalla, N. and Agarwal, P.: A new Multi Point Clamped bi-directional DC-DC converter for renewable energy integration. In: IEEE 8th Power India International Conference, pp. 1-5. IEEE, Kurukshetra, India (2018).
6. Mallick, D., K., Swain, S., C., Sahu, P., K., Jena, S., Roy, S. and Dash, R.: Analysis of isolated bi-directional CLLC DC-DC converters for fast electric-vehicle (EV) battery charging. In: 3rd IEEE International Conference on Industrial Electronics: Developments & Applications, Computing and Engineering, pp. 1-6. IEEE, Bhubaneswar, India (2025).
7. Jegadeesh, K., R., Arunesh, P., Rengaraj, S., Surya, P., S., Vignesh, R.: Bi-directional DC-DC converters for microgrid applications. In: 6th International Conference on Inventive Research in Computing Applications, pp. 185-190. IEEE, Coimbatore, India (2025).
8. Tao, J.: Research on the topology of partial power bidirectional DC-DC converters. Guang Zhou University, Guangzhou, China (2024).
9. Tian, X. and Du, L.: Research on bidirectional DC/DC converter based on Cuk topology. Auto Time 23, 14-16 (2024).

10. Chen, B.: Research on a resonant bidirectional high-gain isolated DC-DC converter based on wide-bandgap semiconductors. Tianjin University, Tianjin, China (2019).

**Open Access** This chapter is licensed under the terms of the Creative Commons Attribution-NonCommercial 4.0 International License (<http://creativecommons.org/licenses/by-nc/4.0/>), which permits any noncommercial use, sharing, adaptation, distribution and reproduction in any medium or format, as long as you give appropriate credit to the original author(s) and the source, provide a link to the Creative Commons license and indicate if changes were made.

The images or other third party material in this chapter are included in the chapter's Creative Commons license, unless indicated otherwise in a credit line to the material. If material is not included in the chapter's Creative Commons license and your intended use is not permitted by statutory regulation or exceeds the permitted use, you will need to obtain permission directly from the copyright holder.

