







Technological Aspects for Viscoelastic Compositions Applications in Hydrocarbons Recovery and Transportation

Ramil N. Bakhtizin^{1,4}, Sayavur I. Bakhtiyarov^{2,4}, Geylani M. Panahov^{3,4} and Eldar M. Abbasov^{*,3,4}

¹ Oil and Gas Transportation Department, Ufa State Oil Technological University
Ufa, Russian Federation

² Mechanical Engineering Department, New Mexico Tech, Socorro, USA

³ Fluid Mechanics Department, Institute of Mathematics and Mechanics, Baku, Azerbaijan

⁴ Research Center of “Resource-saving technologies in the production, transportation and processing of hydrocarbons”, Azerbaijan State University of Economics (UNEC), Baku, Azerbaijan

*eldar.abbasov@imm.az

Abstract. A wide range of technological processes involved in the extraction, transportation, and storage of oil and gas are associated with technical challenges that affect their overall efficiency. In order to address these issues, technological solutions have been developed based on chemically crosslinked polymer compositions that can form gel structures. These viscoelastic systems are used to improve oil recovery, selectively isolate hydrocarbons from water, and facilitate their transportation. Laboratory studies and computational fluid dynamics (CFD) simulations using the FLOW-3D software have confirmed the validity of the power law model for non-Newtonian fluids flowing through cavities and channels with constrictions and expansions. The widespread implementation of these technological solutions in Azerbaijan, Western Siberia, and Vietnam has demonstrated the effectiveness of viscoelastic pigging and separation technologies in increasing oil production and ensuring the efficient transportation of hydrocarbons.

Keywords: Viscoelastic Composition, Polymer Gel, Non-Newtonian Fluid, CFD Simulation, Oil Recovery, Pipeline Transport.

1 Introduction

The technological processes involved in oil and gas extraction, as well as the gathering, transportation, and storage of hydrocarbons, often present various challenges that can lead to reduced productivity and efficiency [1 – 3]. Currently, the oil industry is striving to develop and implement structurally stable materials with controlled properties that can withstand high temperatures, pressure, shear forces, and chemical exposure [4 – 7]. Studies have shown that the use of controlled viscoelastic composite materials

in various oil production processes improves the efficiency and quality of related operations [8 - 10].

On the other hand, mathematical modeling and control of oil production operations involving the use of viscoelastic polymer-based composites require knowledge of the rheophysical properties of these composites under various technological conditions [11]. The processes of mass, momentum, and energy transfer in these composites will be well understood if rheophysical parameters such as viscosity, shear stress, normal stress, and yield strength are accurately measured [12 - 14]. Accurate measurement of these properties is essential for progress in process engineering. However, the rheological and transport properties of these composite materials have not yet been sufficiently studied.

In order to eliminate the complications that arise, special rheo-technologies have been developed based on the use of various chemical compositions. In particular, cross-linked polymer compositions with the ability to form gel systems have become widespread, which are used in the processes of sequential pumping of various hydrocarbon liquids, cleaning pipeline systems from accumulations and pollutants, as a temporary packer to ensure the isolation of the annular space and eliminate the inflow of water from the overlying horizons, silencing production wells with a high gas factor, abnormal reservoir pressure, abnormally low formation pressure, when leveling the pickup profile and, in general, in technologies for increasing oil recovery.

Viscosity is an important rheological parameter for understanding the hydrodynamics and reaction kinetics in the processing of polymer-based composites. The flow velocity and drag resistance in pipelines primarily depend on the viscosity of the composite system. In addition, the rate of structural degradation can be determined by continuously measuring the viscosity of the composition. Based on the dependence of viscosity on shear rate and time, the consistency and overall rheological behavior of the composition can be estimated.

2 Laboratory tests

2.1 Tests on polymeric compositions rheology

In the course of the research, CFD simulations were performed to study the effect of elastic properties on flow characteristics in channels with cavities [15]. The "jet thrust" method was used to measure the elastic properties of the studied liquids.

The Fig. 1 illustrates a modified equipment used for the axial stress measurements. A test liquid by compressed air from a stainless-steel cylinder (1) was provided into a stainless-steel capillary tube (3). This tube had a length 220 mm and an internal diameter of 1.5875 mm. A horizontal jet of test liquid strikes the light aluminum disk (9) connected to load cell (5) and then drains into beaker (6). The pressure on the entrance to the capillary tube was measured by a pressure gauge (4). Using water bath (2) controlled the temperature of the test liquid. The outputs of the load cell (5) and the pressure gauge (4) are fed to computer (7). The load cell was calibrated in a vertical position, with the aluminum disk upward, by placing weights in its center.

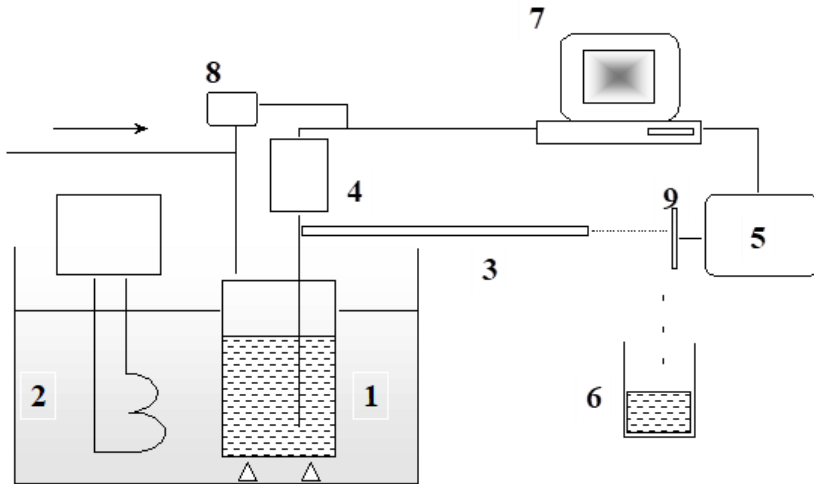

Fig. 1. Modified jet thrust apparatus: 1 – stainless steel cylinder filled by test liquid; 2 – water bath; 3 – capillary tube; 4 – pressure gauge; 5 – load cell; 6 – beaker; 7 – PC; 8 – manometer; 9 – aluminum disk

The results obtained at New Mexico Tech University were confirmed by the Azerbaijani team, where the elastic properties of the compositions were determined by constructing a dependence of the form of $(1/\mu^2) \sim \tau^2$ [16].

To predict the distribution of flow velocities and pressure losses during the flow of a non-Newtonian fluid through a rectangular cavity, FLOW-3D software (Flow-Simulations, Inc.) was used. Two-dimensional numerical simulation of the flow of a non-Newtonian (power law model) fluid in a square cavity was performed using this software package (Fig. 2). Extensive studies of the rheological properties of viscoelastic polymer solutions used in the oil industry have shown that the flow behavior of such liquids can be adequately described by a power law model.

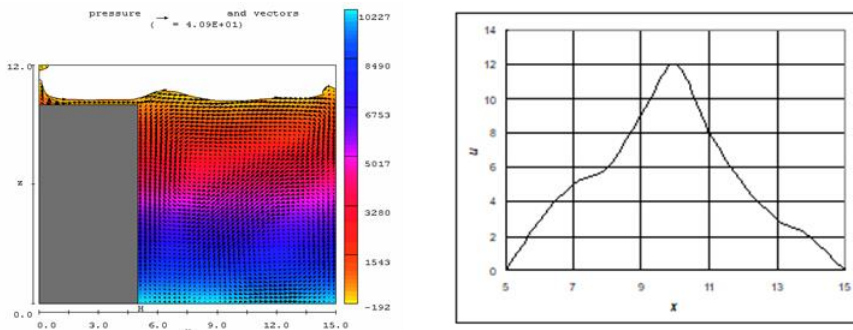

Fig. 2. Flow dynamics of non-Newtonian (power law model) fluid in square cavity

Laboratory studies of the rheophysical properties of polymer compositions and structural components were carried out. As for the production strategy of using polymer compositions in oil production processes, the need to use solutions of crosslinked polymers to form a gel structure was confirmed. The mechanism of formation of gel structures has been experimentally investigated. It has been established that the formation of cross-linked gel structures can be achieved using additives of polyvalent metals and chromium lignosulfonate. It is shown that an increase in the percentage of polyvalent metal in the polymer composition leads to a decrease in the value of the critical shear stress (τ_0) and increases the initial modulus of elasticity G_0 . The presence of these patterns with an increase in the consumption of the crosslinking agent is due to the formation of a grid with a high density of chain links in cross-section. The dynamics of structuring at various temperatures is studied for the developed viscoelastic structures. During the formation of the gel structure, the critical dynamic shear stress was measured at a constant shear rate $\theta = 500$ s⁻¹ and variable temperatures. The change in the viscosity of the system over time was determined. The presence of a maximum in the viscosity dynamics curves indicates the discontinuity of the gel structure during deformation with a constant shear rate (Fig. 3). The results of experimental studies have shown that the deformation behavior of viscoelastic test samples depends on the duration of their storage. An increase in shelf life leads to a decrease in the strength characteristics of the crosslinked compositions, and this may be caused by the inevitable syneresis of the gel.

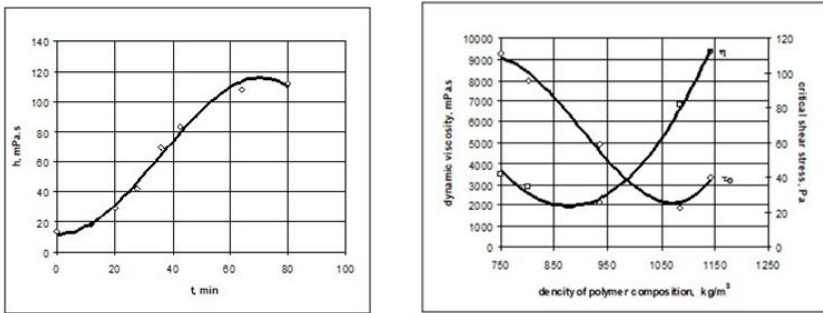

Fig. 3. Rheological characteristics of polymer compositions

For crosslinked gel formulations, the pattern of changes in characteristics under the influence of various factors, such as temperature, pressure, the presence of aggressive media, and the technological holding time, was studied. By increasing the relaxation time relative to the load time, it is possible to regulate the strength characteristics of compositions used in oil and gas production processes. It is necessary to establish the estimated and criterion dependences between the studied parameters and indicators. For this purpose, the following well-known relationship is proposed between the shear strain rate $\dot{\gamma}$ and the stretching multiplicity λ for simple shear:

$$\lambda = \frac{\dot{\gamma}}{2} + \sqrt{\left(\frac{\dot{\gamma}}{2}\right)^2 + 1}, \tag{1}$$

where λ is the multiplicity of stretching.

The value of the maximum λ , expressed in terms of the geometric characteristics of the pipeline bend (risers) is determined by the following formula:

$$\lambda_{\max} = 1 + \sqrt{2d} \quad (2)$$

The criterion for maintaining the integrity of the gel system when it passes through a rectangular pipeline turn can be expressed as follows:

$$1 + \sqrt{2d} < \frac{\gamma_{np}}{2} + \sqrt{\left(\frac{\gamma_{np}}{2}\right)^2 + 1}. \quad (3)$$

After the known transformations, we define:

$$\tau < \frac{P}{\sqrt{32l}} \left(\gamma_{np} - 2 + \sqrt{\gamma_{np} + 4} \right), \quad (4)$$

where: λ_{\max} is the maximum multiplicity of stretching; γ_d - shear deformation; d is the diameter of the pipeline; l is the length of the pipeline.

2.2 Core Flow Tests

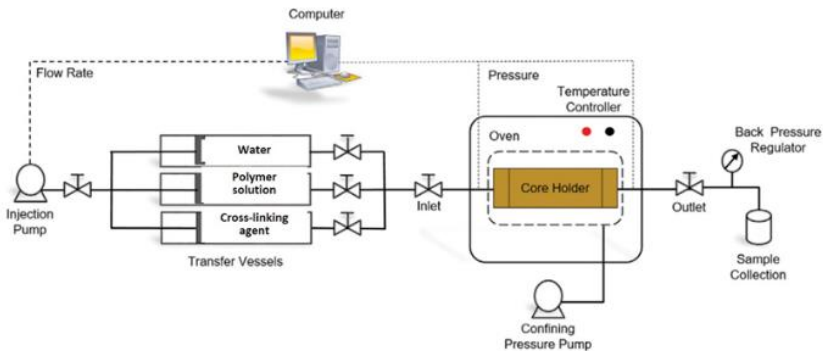

Fig. 4. Experimental setup

There are known methods aimed at increasing oil recovery and increasing the flow resistance of highly permeable washed layers by plugging them with various insulating compounds. Such compositions create conditions for redirecting the injected water to reservoir zones containing residual hydrocarbon reserves and are widely known as "waterproofing compositions" [17]. A series of laboratory experiments on the isolation of water inflow in highly permeable zones of the reservoir was carried out on the model of a porous medium, simulating the process of blocking highly permeable zones of the reservoir on core samples of a porous medium. In the course of the research, the ability to isolate in artificial samples of a porous medium saturated with water with a diameter of 0.032 m and a length of 1.0 m was studied (Fig. 4). During the experiments, the output of the model was injected alternately: C1 = 0.5% aqueous solution of a crosslinking

agent and aqueous solutions of polyacrylamide of various concentrations: $C_2 = 0.05$; 0.1 and 0.5%. The total volume of the chemical mixture was no more than 0.2 of the reservoir pore volume. After that, water was pumped into the entrance of the porous medium model. The blocking effect was determined by the pressure recovery curves of the CVD before and after injection of solutions. As can be seen from the above figure, when using the method, the recovery time of liquid pressure increases (Fig. 4), which is an indicator of a decrease in the hydroconductivity of the core sample as a result of blocking high permeability zones.

Experimental data show that the proposed method has a more pronounced blocking ability. In this case, the rate of gelation depends on the concentration of solutions, as well as on the reaction time of gelation. Practical solutions for preventing corrosion of gas pipelines in conditions of disequilibrium. The causes of corrosion-hazardous conditions in the pipeline cavity include unstable compounds of hydrocarbons with water, and technological conditions that affect the formation of corrosion:

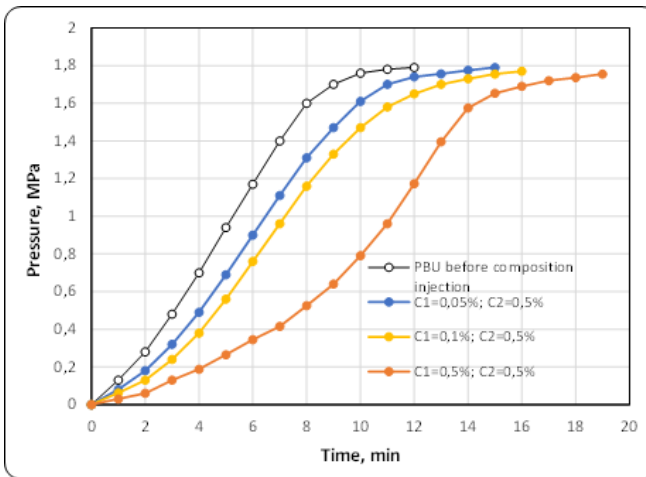

Fig. 5. Pressure build-up curves before and after blocking high-permeable pore zones

- a) the absence of outlet collectors and sewage treatment pipes in the pipeline sections, through which, depending on the terrain, they can constantly remove accumulated liquid;
- b) ineffective cleaning of the pipeline before starting it (purgin);
- c) incomplete gas purification before its supply to the main pipeline.

3 Field cases

The most straightforward approach in this situation is to periodically remove accumulated water from gas pipelines by flushing them with pressurized gas through an open section. As the gas flow speeds up due to the pressure difference, it displaces the contents of the pipeline over a certain period of time. However, when flushing long sections, the effectiveness of the cleaning process is not uniform along the length of the pipeline. At the beginning of the section, where the flow speed is lower than at the end, the removal of sediment is less efficient. One disadvantage of this method is the loss of a significant

amount of gas and the potential for environmental pollution. After the construction of the pipeline, flushing through an open section is often done simultaneously with the passage of cleaning devices such as pigs or scrapers [5].

It is known that the effectiveness of cleaning also depends on the nature of contamination, thermal gas dynamics conditions, and technological cleaning of the inner cavity of gas pipelines using cleaning devices of various designs limit the possibility of their use.

Recently, the technology of cleaning the inner cavity of gas pipelines using cleaning devices of various designs and principles of operation has been dominant [6, 9]. The technological process of cleaning gas pipelines is carried out without interrupting pipeline operation and consists of three main elements: initiating the cleaning device, monitoring its passage through the cleaned area and the process of receiving cleaning products and the cleaning device in at the end of the area being cleaned. Special equipment is designed for the launch and reception of cleaning devices, including launch and reception chambers, an alarm system, recycling tanks, lifting mechanisms of cleaning devices, technological supports and other equipment. The variable cross-section of pipelines, the presence of bends, overhead clamps, etc. limit the possibility of using scrapers and special pigs of various shapes and designs.

In order to effectively clean gas pipelines from various deposits, this study proposes the use of viscoelastic compositions, that restore of pipeline capacity and reduction of pressure losses. The composite formulation makes it possible to efficiently carry out complete cleaning of the pipeline with complex geometries [19]. Unlike conventional systems, viscoelastic compositions sufficiently meet the required set of performance criteria and have the following adjustable properties: relaxation, thixotropy, viscoelasticity, and dynamic hysteresis.

The technological method aims to ensure the remove water, condensate, and solid deposits from the pipeline by injecting a freshly prepared viscoelastic composition into the cavity and subsequently displacing it with the transported product. The proposed concept is based on the selecting suitable viscoelastic compositions for cleaning gas pipelines in order to improve the performance of the pipeline system. When carrying out the technological operation of cleaning the pipeline, the required volume of the viscoelastic composition is calculated based on the geometric parameters of the pipeline. The volume of the composition is prepared immediately before use in a special container. The prepared composition is pumped under pressure into the pipeline and then a back pressure is created sequentially, providing appropriate conditions for the movement of the composition in the pipeline cavity and preventing blockages in areas of variable geometry and slipping of the pushing product.

In 1990-2017, technological operations for cleaning gas pipelines were carried out on the pipelines of the SOCAR oil company: the Sangachal field – 340 km; the 28 May field - 143 km; the Oil Stones field - 36 km; the Gum Adası field – 40 km; the Absheron field – 54 km. The gasoline pipeline between the cities of Grozny and Budyonovsk, 273 km long and 250 mm in diameter, was successfully cleaned. High-pressure gas pipelines with a length of more than 100 km have been cleaned at Russian oil and gas fields: Langepasskoye and Uryevskoye (Western Siberia); in the oil companies “Udmurtneft” and “Orenburgneft”.

A specially developed composition [20] was applied on the 1,500 m long section of the gas pipeline between the offshore production platform MSP-7 and MSP-5 to the Dragon field “Vietsovpetro” Company (Fig. 5). The operation of offshore gas pipelines is one of the complex and responsible components of the technological process of reser-

voir development. Maintaining stable operation of the gas pipeline is of particular importance in the critical conditions of the underwater location of the gas pipeline, the presence of risers, high corrosion activity of the medium and the transported product, and a decrease in pipeline capacity due to the accumulation of liquid in the pipe cavity.

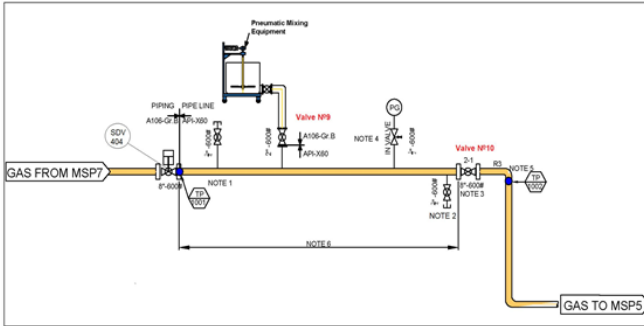

Fig. 6. The launch site of the viscoelastic compound on the MSP-7 platform (White Tiger oil field)

Offshore oil and gas production poses particular challenges for gas pipeline cleaning, such as the absence of launch chambers for conventional mechanical cleaning tools, complex pipeline layouts, and long (70-meter) risers on platforms. The proposed new method uses a specially developed polymer gel. This gel is injected into the gas pipeline, where it quickly forms a stable, viscoelastic coating as it moves. The resulting liquid then enters a collection and separation system located on the offshore platform, where it is separated from the gas. When flowing through the pipeline, the accumulated liquid is displaced into the collection and separation system on the offshore platform. During the gas pipeline cleaning process, approximately 8 m³ of water and condensate was displaced from the pipe at a pressure of 5 atm, and the viscoelastic composition (gel pig) injected at the MSP-7 platform was successfully received at the receiving node on the MSP-5 platform. The results obtained can be used in the analysis and calculation of transient conditions in gas pipeline systems in order to avoid accidents and corrosion of the pipeline during gas transportation (Fig. 6).

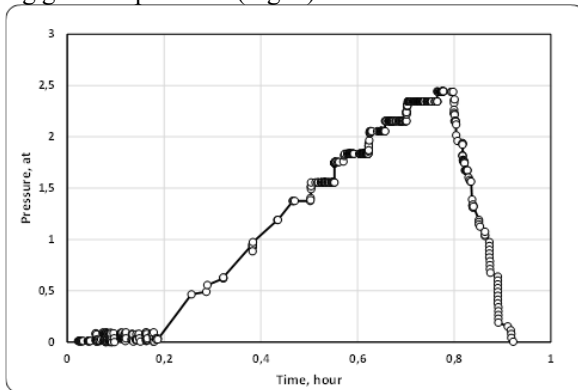

Fig. 7. Technological indicators of displacement of a composite viscoelastic system in a gas pipeline

The effects of pressure drop fluctuations during the advancement of the viscoelastic composition, observed during the cleaning of the gas pipeline, may indicate a multiple reversible elongation of polymer macromolecules, which is equivalent to the effects of self-oscillating discharge from the nozzles, an abnormal increase in resistance during flow in the pipes, etc.

The developed technological solutions are an effective alternative to mechanical pigs for cleaning the inner cavity of pipelines, preventing accidents and corrosion of gas pipelines during gas transportation.

4 Conclusion

The conducted theoretical and experimental studies have made it possible to establish that the use of controlled viscoelastic compositions based on polymers is an effective way to increase the productivity and reliability of technological processes in the oil and gas industry. The CFD modeling has confirmed the applicability of the power law model to describe the behavior of non-Newtonian fluids, which makes it possible to more accurately predict flow parameters and pressure losses under various technological conditions.

Optimal conditions for the formation of gel structures providing stability and mechanical strength under the influence of high temperatures and pressures have been determined. It has been established that crosslinked polymer gels are effective in isolating water inflow and blocking highly permeable zones of the reservoir, which contributes to increased oil recovery.

A technology for gas pipelines cleaning using viscoelastic compositions has been developed and successfully tested, ensuring the restoration of throughput and reducing the accident rate of pipeline systems.

The results obtained have important scientific and practical significance and can be used in the design and optimization of technological processes for the recovery, transport and storage of hydrocarbons, as well as in the development of methods to prevent corrosion and emergencies in pipeline systems.

References

1. Yu, A. C., Appel, E. A., Meis, C. M., Schlaad, H., & Langer, R. (2016). Scalable manufacturing of biomimetic moldable hydrogels for industrial applications. *Proceedings of the National Academy of Sciences*, 113(38), 10575–10580. <https://doi.org/10.1073/pnas.1618156113>.
2. Misra, C. (2013). Design of gelled fluid for debris removal in subsea pipeline pigging (SPE technical paper / conference paper). *SPE / OnePetro proceedings*. (Design & case examples for gelled fluids in subsea cleaning).
3. EP 0630694 A2. (1994). Cleaning pipeline interiors using gel pigs (patent). European Patent Office.
4. CN 107614957 B. (2019). Method for sealing a pipeline using a gel pig (Chinese patent; English abstract available)
5. Han, J., Sun, J., Lv, K., Yang, J., & Li, Y. (2022). Polymer gels used in oil-gas drilling and production engineering. *Gels*, 8(10), 637. <https://doi.org/10.3390/gels8100637>.

6. Lu, S., Bo, Q., Zhao, G., Shaikh, A., & Dai, C. (2023). Recent advances in enhanced polymer gels for profile control and water shutoff: A review. *Frontiers in Chemistry*, 11, 1067094.
7. Davoodi, S., Al-Shargabi, M., Wood, D. A., & Rukavishnikov, V. S. (2023). A comprehensive review of beneficial applications of viscoelastic surfactants in wellbore hydraulic fracturing fluids. *Fuel*, 338, 127228. <https://doi.org/10.1016/j.fuel.2022.127228>.
8. Shibaev, A. V., et al. (2021). Novel trends in the development of surfactant-based fracturing fluids. (Review).
9. Fakher, S., Khlaifat, A., Mokhtar, K., & Abdelsamei, M. (2024). Assessment of two cross-linked polymer systems including hydrolyzed polyacrylamide and acrylic acid–hydrolyzed polyacrylamide co-polymer for CO₂ and formation water diversion through relative permeability reduction in unconsolidated sandstone formation. *Polymers*, 16(24), 3503. <https://doi.org/10.3390/polym16243503>.
10. Experimental studies of the effectiveness of cleaning the internal cavity of pipelines with hyperelastic pigs (Stetsiuk, S. M., 2022). *Oil & Gas Power Engineering*, 2(38), 62-75. [https://doi.org/10.31471/1993-9868-2022-2\(38\)-62-75](https://doi.org/10.31471/1993-9868-2022-2(38)-62-75).
11. Analysis of Factors Affecting the Pigging Effect (Li, J., & Li, Y., 2024). *Academic Journal of Science and Technology*. <https://doi.org/10.54097/b5t0fv54>
12. Application of Superparamagnetic Nanoparticle (SPM-NP) Heating in Wax Removal during Crude Oil Pipeline Pigging (Li, H., Li, W., Wang, J., Wang, W., Zhang, Y., Teng, L., Yin, P., & Huang, X., 2022). *Energies*, 15(17), 6464. <https://doi.org/10.3390/en15176464>.
13. A Comprehensive Analysis of In-Line Inspection Tools and Technologies for Steel Oil and Gas Pipelines (Parlak, B. O., & Yavasoglu, H. A., 2023). *Sustainability*, 15(3), 2783. <https://doi.org/10.3390/su15032783>.
14. Synthesis and Evaluation of Plugging Gel Resistant to 140 °C for Lost Circulation Control: Effective Reduction in Leakage Rate in Drilling Process (Xie, L., 2024). *Polymers*, 16(12), 1658. <https://doi.org/10.3390/polym16121658>.
15. Bakhtiyarov S.I., Panahov G.M., Abbasov E.M. and Heydarov C.Y. Rheological Measurements on Viscoelastic Self-Healing Composites Used in Oil Industry // Proceedings of Conference “Transport Phenomena in Manufacturing and Materials Processing”, Houston, TX, June 19-23, (2005), (USA). – pp. 10-15.
16. Shahverdiev A.H., Mandrik I.E., Bahtiyarov S.I., Abbasov E.M. Effektivnost' vyazkouprugih kompozitsij v slozhnyh tekhnologicheskikh operatsiyah // «Izobreteniya i innovatsii v neftegazovoj promyshlennosti», № 6, 2005. – S. 55 – 61.
17. Geylani M. Panahov, Eldar M. Abbasov, Shahin Z. Ismayilov & Vusale D. Balakchi (2021) In-depth isolation of highly permeable zones for reservoir conformance control, *Journal of Dispersion Science and Technology*, DOI: 10.1080/01932691.2021.2006062.
18. Shahverdiev A.H., Panahov G.M., Abbasov E.M. Patent RF № 2174879 «Sposob oчитки vnutrennej polosti gazoprovoda», Federalnaya sluzhba po intellektual'noj sobstvennosti, patentam i tovarnym znakam (ROSPATENT), 2000.
19. Bakhtiyarov, S.I., Panakhov, G.M., Abbasov, E.M. Rheological Characterization of Viscoelastic Composite Systems Used in Oil Industry // Book “Characterization of Materials, Metals and Minerals”, M. E. Schlesinger, ed., TMS Publications, 2005. - pp. 11 – 18.
20. Geylani M. Panakhov, Eldar M. Abbasov, Alexey N. Ivanov, Do Thanh Chung, & Le Viet Dzung. (2024). Nonequilibrium effects during the flow of gas mixtures in pipelines and methods for preventing pipeline corrosion. In Proceedings of the Scientific and Practical Conference of the Vietsovpetro Oil Company dedicated to the production of 250 million tons of oil (pp. 145–154). Vung Tau, Vietnam.

Open Access This chapter is licensed under the terms of the Creative Commons Attribution-NonCommercial 4.0 International License (<http://creativecommons.org/licenses/by-nc/4.0/>), which permits any noncommercial use, sharing, adaptation, distribution and reproduction in any medium or format, as long as you give appropriate credit to the original author(s) and the source, provide a link to the Creative Commons license and indicate if changes were made.

The images or other third party material in this chapter are included in the chapter's Creative Commons license, unless indicated otherwise in a credit line to the material. If material is not included in the chapter's Creative Commons license and your intended use is not permitted by statutory regulation or exceeds the permitted use, you will need to obtain permission directly from the copyright holder.

