



Simulation of Gasification Process and Techno-Economic Study on Waste to Energy from Municipal Solid Waste in Indonesia (Case Surakarta WTE)

Janter Naibaho^{1,2,*} and Bambang Sudarmanta²

¹ PT PLN (Persero), Renewable Energy Division, 12160 Jl. Trunojoyo Blok M-I No.135, Kebayoran Baru, Jakarta, Indonesia

² Institut Teknologi Sepuluh Nopember, Mechanical Engineering Department, 60111 Kampus ITS Sukolilo, Surabaya, Indonesia

* Janter.naibaho@pln.co.id

Abstract. This study uses Aspen Plus to simulate the gasification process in downdraft gasifier according to the characteristics of waste in Indonesia, using a combination of air and oxygen with equivalence ratios (ER) 0.23, 0.30 and 0.40. From the simulation results, it was obtained that the highest value of combustible gas was obtained from the simulation of ER 0.23 with a composition of CO 16.59%, CH₄ 1.53 and H₂ 12.92%. Performance analysis was carried out such as combustible gas composition, syngas lower heating value, cold gas efficiency, carbon conversion rate, and syngas production rate. The economic review concluded that with a total investment of 22.92 million USD for waste gasification of 345.6 tons/day which produces electricity of 5 MW, capacity factor (CF) of 80% and electricity tariff of 13.35 cUSD/kWh; The results of the financial analysis were obtained from the IRR Project 11.41%, IRR Equity 10.23%, Payback Period 7.82 years and DSCR 1.29. If the revenue is added with the carbon credit of 2 USD/tonCO_{2e} or the tipping fee income of 15 USD/ton, it will result in an IRR Project of 10.67% or 13.53% respectively. The potential reduction of carbon emissions from waste gasification into electricity is 63,898.77 tons of CO_{2e}/year.

Keywords: Waste to Energy, Gasification, Aspen Plus Simulation, Techno-economic Analysis, Carbon Emission Reduction.

1 Introduction

Waste generation in Indonesia based on data input carried out by 317 regencies/cities throughout Indonesia in 2024 has reached 34,221,607.36 tons/year [1]. Waste management by piling waste in landfills will cause new problems, namely the potential release of methane gas (CH₄) emissions stored in landfills. Reducing greenhouse gas (GHG) emissions from municipal solid waste (MSW) treatment can be a very cost-effective way in terms of mitigation [2]). Therefore, it is necessary to carry out more effective waste management methods to reduce the adverse impact on the environment. Waste generation if not managed properly will result in serious problems for the

environment both on the surface and groundwater; and public health [3]. Processing waste into energy has an important role in overcoming environmental problems and can produce clean energy as a substitute for fossil fuels [4]. In the RUPTL 2025-2034, PLN has included a total plan to develop waste into electrical energy of 400 MW[5].

1.1 Simulation of the municipal waste gasification process

Waste gasification is a process that converts municipal solid waste, into carbon monoxide, hydrogen and methane by reacting raw materials with a controlled amount of oxygen and/or steam at high temperatures. The resulting gas mixture is called synthesis gas or syngas and is itself a fuel. Gasification is a method of extracting energy from different types of organic matter. The advantage of gasification is that the use of syngas is potentially more efficient than direct combustion of the original fuel because it can be burned at higher temperatures [6]. Downdraft gasifiers are often chosen because of a number of important advantages in municipal solid waste treatment due to their high carbon conversion efficiency which means more energy can be extracted from the raw material and low tar production which makes the gases from the gasification cleaner and suitable for direct power generation applications [7]. In this study, it refers to the previous research model where a kinetic model for a downdraft gasifier is assembled and incorporated into a flowsheet using Aspen Plus with the aim of performing detailed process analysis. The model is organised according to the assumption that in a downdraft gasifier pyrolysis, oxidation and reduction occur almost as separate consecutive processes, with the pyrolysis considered as an instantaneously occurring process while oxidation and reduction are governed by chemical kinetics[8]. The staged downdraft gasification framework and the key chemical reaction pathways implemented in this work are illustrated in Fig. 1.

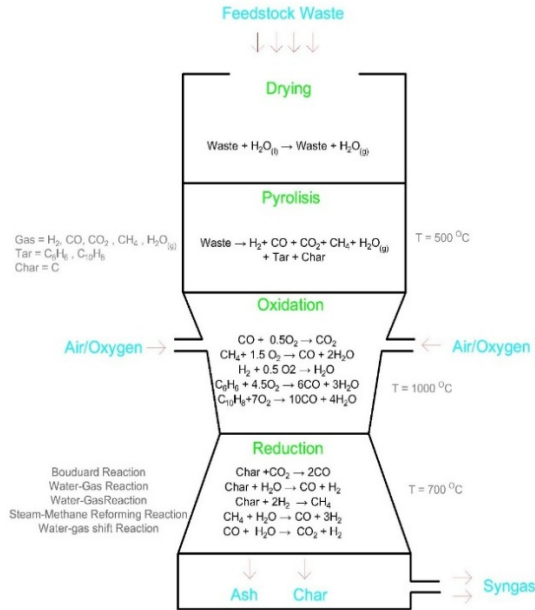

Fig. 1. Schematic of waste gasification simulation in downdraft gasifier with chemical reaction details

1.2 Economic analysis of municipal waste gasification

The basis for calculating the economic study uses technical parameters such as the capacity of the power plant, the amount of waste processed, the number of days of operation, the efficiency of energy conversion or the efficiency of the plant, the factor of capacity and the annual amount of energy distributed, the life of the project, the cost of capital and the operation and maintenance of the plant. To analyse the economic feasibility of the project, several key parameters are used as follows:

- 1) Net Present Value (NPV),
- 2) Internal Rate of Return (IRR),
- 3) Payback Period (PP),
- 4) Debt Service Coverage Ratio (DSCR),
- 5) Weighted Average Cost of Capital (WACC)

Furthermore, the calculation of carbon emission reduction as potential credit carbon income is carried out. Baseline emissions calculated based on 2019 Refinement to the 2006 IPCC Guidelines for National Greenhouse Gas Inventories [9]. Meanwhile, project emissions are calculated based on the Carbon Emission Calculation Method [10] which refers to the CDM Methodology Booklet [11].

2 Process Description and Simulation

The simulation of the waste gasification process in the downdraft gasifier was modelled using Aspen Plus software, where the waste was defined as nonconventional fuel because it was not in the conventional database.

2.1 Input for Simulation

The waste data used for the Simulation process uses waste data in Surakarta city with proximate analysis and ultimate analysis as follows:

Table 1. Municipal waste data in Surakarta city [12]

Proximate Analysis		Ultimate Analysis	
Moisture	10.700	Ash	14.398
FC	13.565	Carbon	43.483
VM	61.323	Hydrogen	6.183
Ash	14.412	Nitrogen	1.245
		Chlorine	0.089
		Sulfur	0.141
		Oxygen	34.461

By using the above waste inputs, if using full air as a gasification agent, a stoichiometric air calculation of 111,498.60 kg/hr is obtained, while if full oxygen is used, a stoichiometric oxygen calculation of 25,872.41 kg/hr is obtained. Based on schematic data from Surakarta gasification WTE [12], the mass flow rate of the waste to be put into the gasifier is 14400 kg/hr with a combination gasification agent consist of the Air 20752 kg/hr and Oxygen 1152 kg/hr, which is from calculation equal to Equivalence Ratio (ER) 0.23. Equivalence ratio (ER) is an important design parameter for a gasifier. It is the ratio of the actual air-fuel ratio and the stoichiometric air-fuel ratio[13].

2.2 Gasification Process Simulation

The process stages in a gasification reactor start from the process of drying, pyrolysis, oxidation and reduction to produce syngas.

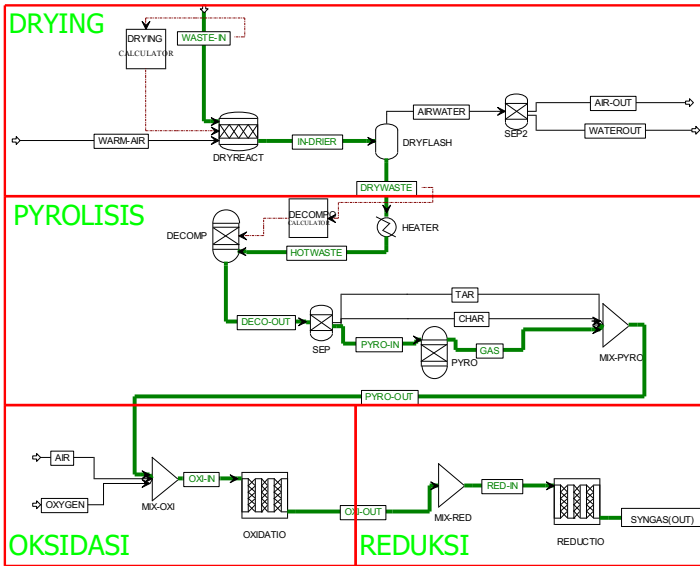

Fig. 2. Simulation of the waste gasification process in Aspen Plus

This schematic represents the simulation flow of municipal solid waste (MSW) gasification in a downdraft gasifier using Aspen Plus, which is divided into four main zones: Drying, Pyrolysis, Oxidation, and Reduction (see Fig. 2). Each block represents a unit operation simulating the respective chemical and thermal processes. In this study, the aspen plus model and kinetic reaction used earlier were developed by [8] [14]. Description of the reactor block used as shown in the following table:

Table 2. Aspen plus reactor block used in the simulation

Reactor Block	Description
RSTOIC	Simulating the drying process with the help of drying calculator Fortran based. $(\text{Waste} + \text{H}_2\text{O}(\text{l}) \rightarrow \text{Waste} + \text{H}_2\text{O}(\text{g})) \quad (1)$
RYIELD	Simulating the pyrolysis proses, converting waste into gaseous, solid and liquid components with the help of decomposition calculator Fortran based. $(\text{Waste} \rightleftharpoons \text{H}_2 + \text{CO} + \text{CO}_2 + \text{CH}_4 + \text{H}_2\text{O}(\text{g}) + \text{Tar} + \text{Char}) \quad (2)$
RGIBBS	Simulating reactions between conventional components through Gibbs free energy minimisation
	Computes the kinetics of the oxidation zone
	$\text{CO} + 0.5\text{O}_2 \rightarrow \text{CO}_2 \quad (3)$
	$\text{CH}_4 + 1.5\text{O}_2 \rightarrow \text{CO} + 2\text{H}_2\text{O} \quad (4)$
	$\text{H}_2 + 0.5\text{O}_2 \rightarrow \text{H}_2\text{O} \quad (5)$
	$\text{C}_6\text{H}_6 + 4.5\text{O}_2 \rightarrow 6\text{CO} + 3\text{H}_2\text{O} \quad (6)$
	$\text{C}_{10}\text{H}_8 + 7\text{O}_2 \rightarrow 10\text{CO} + 4\text{H}_2\text{O} \quad (7)$
RPLUG	Computes the kinetics of the reduction zone
	$\text{Char} + \text{CO}_2 \rightarrow 2\text{CO} \quad (8)$
	$\text{Char} + \text{H}_2\text{O} \rightarrow \text{CO} + \text{H}_2 \quad (9)$
	$\text{Char} + 2\text{H}_2 \rightarrow \text{CH}_4 \quad (10)$
	$\text{CH}_4 + \text{H}_2\text{O} \rightarrow \text{CO} + 3\text{H}_2 \quad (11)$
	$\text{CO} + \text{H}_2\text{O} \rightarrow \text{CO}_2 + \text{H}_2 \quad (12)$

The products of this process consist of **Syngas** (CO, H₂, CH₄, etc.) which is ejected from the bottom of the reactor and can be purified or directly used as fuel and **Ash** the remaining solids from the reaction process are removed from the reactor base.

Next, a gasification performance analysis was carried out by calculating the values of cold gas efficiency (CGE), carbon conversion rate (CCR) and syngas production rate (SPR).

CGE measures how effectively a gasification system converts input fuel into energy in the form of syngas

$$CGE = \frac{\dot{v}_{syngas} \times LHV_{syngas}}{\dot{m}_{waste} \times LHV_{waste}} \quad (13)$$

CCR measures how much carbon fraction of the input fuel is successfully converted into gasification products such as CO, CO₂, CH₄, and other hydrocarbons.

$$CCR = \frac{m_{syngas} (Y_{CO_2} \frac{12}{44} + Y_{CO} \frac{12}{28} + Y_{CH_4} \frac{12}{16})}{m_{waste} \cdot Y_C} \times 100\% \quad (14)$$

SPR Measures the rate of synthesis gas (syngas) formation compared to the input fuel in the gasification process

$$SPR = \frac{\text{syngas flow rate } (\frac{Nm^3}{h})}{\text{waste feeding rate } (\frac{kg}{h})} \quad (15)$$

3 Result and discussion

3.1 Simulation Results and Validation

From the waste gasification process in Aspen Plus, the simulation results were obtained with the composition of H₂ 13.61%, CO 16.59%, CO₂ 21.71%, CH₄ 1.58%, C₆H₆ 0.16% and N₂ 46.34%. LHV calculated 4.36 MJ/m³ from volumetric heating value of product gas from gasification[15]

The results of the above simulation were validated using data from the Syngas Sampling and Analysis Report of the Putri Cempo Gasification WTE Power Plant, Surakarta City. Where is the data taken on October 18, 2022, the results of the analysis show that the average content of CO, CO₂, CH₄, C_nH_m, H₂, O₂, N₂ and LHV, respectively is around 12.56%, 17.06%, 3.10%, 0.18%, 12.52%, 0.00%, 54.58%, and 3.92 MJ/m³. Meanwhile, the data taken on October 20, 2022, shows that the average content of CO, CO₂, CH₄, C_nH_m, H₂, O₂, N₂ and LHV, is around 13.65%, 14.84%, 3.01%, 0.21%, 10.95%, 0.00%, 57.33%, and 3.89 MJ/m³, respectively (Fig. 3).

Table. 3 shows the comparison between the simulation results at ER 0.23 and actual syngas composition from two commissioning tests of the Surakarta WTE plant. The

Table 3. Syngas composition simulation vs commissioning data

Comp.	Simulation 01-Jun-25	Comms.1 18-Oct-22	Deviation	Comms.2 20-Oct-22	Deviation
CO	16.59	12.56	32.05%	13.65	21.51%
CO ₂	21.71	17.06	27.28%	14.84	46.32%
CH ₄	1.58	3.1	49.02%	3.01	47.49%
C _n H _m	0.1649	0.18	8.37%	0.21	21.46%
H ₂	13.61	12.52	8.71%	10.95	24.30%
O ₂	0	0	0%	0	0%
N ₂	46.34	54.58	15.09%	57.34	19.18%
LHV (MJ/m ³)	4.36	3.92	11.29%	3.89	12.14%

simulation closely matches the measured values for CO and H₂, while a slight overestimation is observed for CH₄ and CO₂. The simulation predicted lower values of CH₄ than the actual plant data. This difference is likely due to tar cracking and CH₄ oxidation occurring in the real gasifier, which are not fully captured in the simulation model. Additionally, the simulation assumes idealized reaction conditions, while real plant variability in feedstock and operating dynamics may lead to increase methane formation in real samples. The nitrogen (N₂) content in the simulation is lower than in the actual data, likely due to idealized air input assumptions. Despite minor deviations, the overall trend confirms that the simulation model accurately represents the syngas characteristics under practical operating conditions.

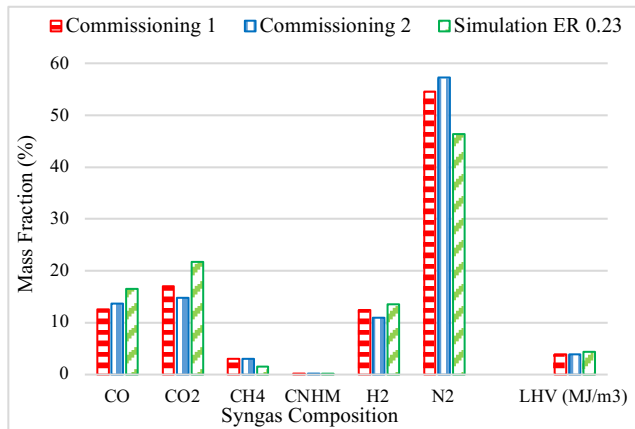

Fig. 3. Comparison of simulation model with WTE gasification commissioning data

Although the simulation results show a deviation; however, the syngas composition trends align with the observed data. This simulation will also be analyzed for sensitivity to determine the parameters that affect the results of syngas. Sensitivity will be carried out by varying the number of gasification agents entering the oxidation stage, so that the target syngas parameters can be known. The gasification simulation model was followed by varying the flow rate of air mass and oxygen into the gasifier for ER 0.3 and ER 0.4, as summarized in Fig. 4.

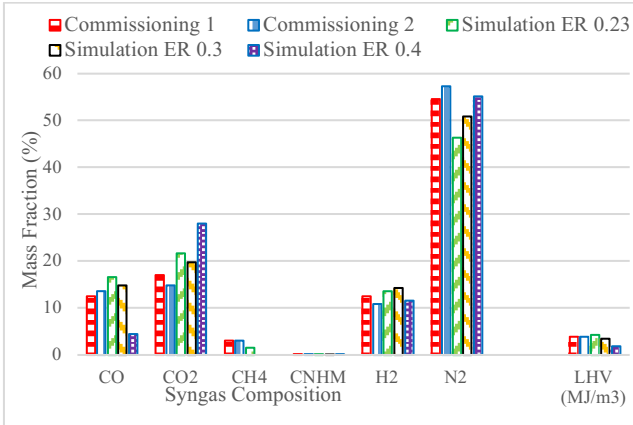

Fig. 4. Comparison of simulation model ER 0.23, 0.30 and 0.40 with WTE gasification commissioning data

Simulation at ER 0.23 shows the closest match to both commissioning datasets, especially in CO and H₂ content, indicating optimal partial oxidation. Higher ER (especially 0.4) results in increased CO₂ and N₂, due to more complete combustion and nitrogen dilution from air input. CH₄ and C_NH_M components are slightly overestimated or underestimated in simulation, but trends remain consistent with measured values. The LHV from ER 0.23 also aligns best with measured data, confirming it yields the most energy-rich syngas among the simulations.

3.2 Performance Analysis of Gasification Process Simulation

From the simulation results of ER 0.23, the values of CCE, CCR and SPR were calculated as follows: 82.22%, 79.76%, 3.68. Simulation results of ER 0.30 the values of CCE, CCR and SPR were calculated as follows 69.55%, 79.75% 4.05, and for simulation results of ER 0.40 the values of CCE, CCR and SPR were calculated as follows 41.78%, 79.77%, 4.47 (Fig. 5).

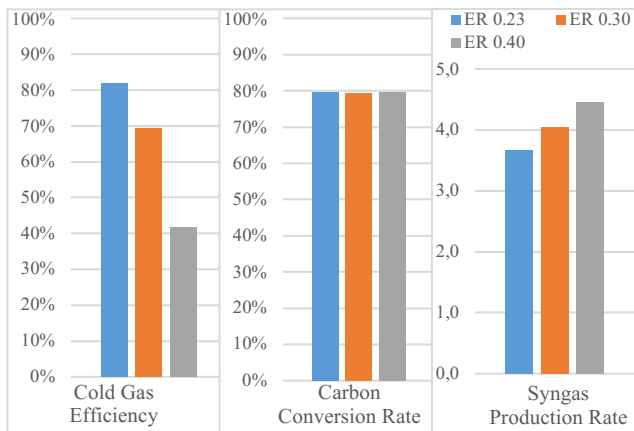

Fig. 5. CGE, CCR, and SPR values from the simulation of the gasification process

Graph illustrates the simulation results of gasification performance at three equivalence ratios (ER 0.23, 0.30, and 0.40). The Cold Gas Efficiency (CGE) is highest at ER 0.23, indicating the most effective energy conversion from waste to syngas. The Carbon Conversion Rate (CCR) remains relatively constant around 80% across all ER values, showing stable carbon utilization. Meanwhile, the Syngas Production Rate (SPR) increases with higher ER, but this comes at the cost of lower energy efficiency due to higher nitrogen and carbon dioxide dilution. Thus, ER 0.23 offers the best balance between energy efficiency and syngas quality.

3.3 Economic Analysis of Gasification WTE

The estimated cost of a gasification WTE project includes Engineering, Procurement, and Construction (EPC) costs, Non-EPC costs and Operating and Maintenance costs (O&M costs).

Table 4. Total Project cost estimation and operating & maintenance costs [12]

EPC and Non EPC Cost		
Parameter	Value	Unit
EPC Cost		
1) Gasifier dan Gas Engine	6	Million USD
2) BOP	1.5	Million USD
3) Waste Pretreatment System	3.82	Million USD
4) 20kV MV Distribution Grid	0.51	
5) EPC Cost	6	Million USD
6) Contingency (5%)	0.86	Million USD

EPC and Non EPC Cost		
Parameter	Value	Unit
EPC Cost		
7) Tax	1.8	Million USD
Total Cost EPC Pembangkit & JTM 20 kV	20.51	Million USD
Non EPC Cost		
1) Development costs	1	Million USD
2) Initial working capital	0.1	Million USD
3) Financing Costs	0.1	Million USD
4) IDC	1.21	Million USD
Total Non-EPC Cost	1.41	Million USD
Total Project Cost	22.92	Million USD
Fix O&M Cost	1.49	Million USD
Variable O&M Cost	0.26	Million USD

The total Engineering, Procurement, and Construction cost is USD 20.51 million, which includes key components such as the gasifier, gas engine, balance of plant (BOP), waste pretreatment system, and 20kV medium-voltage grid. Additionally, non-EPC costs, including development, initial capital, financing, and interest during construction (IDC)—amount to USD 1.41 million. This brings the total capital investment to USD 22.92 million. The assumptions to calculate the economic feasibility of the gasification power plant used are as follows:

Table 5. Economic assumptions of gasification WTE projects

Project Economic Assumptions			
Parameter	Value	Unit	Reference
Powerplant Capacity (Net)	5	MW	WTE Surakarta
Capacity Factor	80	%	CF Gasification
Interest Rate p.a	7	%	MEMR Investment Guidance
Debt to Equity Ratio	70:30		MEMR I.G
Electricity Tariff	0.1335	USD/kWh	Pres.Reg 35/2018
Fix O&M Cost	0.0425	USD/kWh	WTE Surakarta
Variable O&M Cost	0.0074	USD/kWh	WTE Surakarta
Tipping Fee	0	USD/ton	WTE Surakarta
Construction Period	2	years	MEMR I.G
Repayment Period	10	years	MEMR I.G
Contract Duration	20	years	MEMR I.G
WACC	7.28	%	Calculated
Corporate Income Tax	25	%	Tax Law

The annual fixed variable O&M cost is reflecting the recurring expenses required to operate and maintain the facility efficiently. Using project economic assumption and considering the feasibility parameter where the project's NPV must be positive, the IRR must be greater than WACC, the Debt Service Coverage Ratio is greater than 1.2 x, and the payback period assumes less than 8 years, the results of the financial model calculation for gasification WTE are feasible.

Table 6. Summary of the financial calculation model

Summary of the financial calculation model		
NPV Project (million USD)	8,58	Feasible
IRR on Equity	12,31%	Feasible
IRR on Project	10,67%	Feasible
Payback Period (years)	7,57	Feasible
DSCR	1,47	Feasible

The project shows strong financial feasibility with a Net Present Value (NPV) of USD 8.58 million, indicating a positive return above the investment cost. The Internal Rate of Return (IRR) on equity is 12.31%, and the IRR on the overall project is 10.67%, both exceeding the assumed WACC (7.28%), which confirms the project's profitability. The payback period is calculated at 7.57 years, within the acceptable investment timeframe (<8 years). Additionally, a Debt Service Coverage Ratio (DSCR) of 1.47 reflects good capability to meet debt obligations. Overall, these metrics confirm that the project is financially viable. While the financial model is technically comprehensive in static terms, it does not incorporate dynamic macroeconomic risks such as inflation, currency volatility, or potential regulatory changes. Sensitivity analysis was conducted to evaluate how changes in key economic parameters affect the financial viability of WTE gasification project. The analysis assessed variations in total project cost, capacity factor, and electricity tariff, as well as the impact of introducing tipping fee income and carbon credit revenue. The financial sensitivity of the model is calculated with the following results:

Table 7. Financial model sensitivity analysis

Parameter	Sensitivity	Sensitivity Analysis			DSCR
		IRR Equity	IRR Project	Payback Period	
Base Case (No TF dan CC)		11,41%	10,23%	7,82	1,42
Total Project Cost (Base: 22.92 million USD)	Up 10%	9,30%	8,98%	8,60	1,29
	Down 10%	13,81%	11,69%	7,04	1,57
Capacity Factor (Base: 80%)	Up 10%	13,66%	11,55%	7,11	1,56
	Down 10%	9,01%	8,85%	8,69	1,28

Parameter	Sensitivity	IRR Equity	IRR Project	Payback Period	DSCR
Electricity Tariff (Base: 13.35 cUSD/kWh)	Up 10%	13,73%	11,55%	7,11	1,57
	Down 10%	9,07%	8,85%	8,69	1,28
Input TF (USD/ton)	15,00	18,43%	13,53%	6,22	1,79
Input CC (USD/tonCO₂e)	3,00	12,31%	10,67%	7,57	1,47

If the project cost increases by 10%, the Capacity Factor decreases by 10% and the Electricity Tariff decreases by 10%, then the results of the project's sensitivity become unfeasible by using the previous feasibility parameters.

3.4 Carbon Emission Reduction

In addition to economic value, gasification WTE projects also have an important contribution to reducing greenhouse gas emissions. Municipal waste that is usually dumped in landfills produces methane (CH₄) emissions that have 25 times greater global warming potential than CO₂. Through the gasification process, methane emissions can be significantly controlled.

The reduction in carbon emissions is obtained from the difference baseline emissions without the presence of Gasification WTE (business as usual) with the project emissions produced if the Gasification WTE project is build and operate. Emission Baseline Scenario where waste is allowed to decompose in landfills without the use of methane gas so that emissions are high. Meanwhile, Project Scenario Emissions are Waste processed through gasification while produces more controlled CO₂ and some energy is utilized.

Baseline emissions were calculated using the IPCC method [9]. A more detailed baseline emission calculation (tier 3) is calculated based on methane gas emissions produced since the Putri Cempo Landfill began operations in 1985 by considering the first order decay (FOD) parameter, which is the rate of decomposition of organic waste directly depending on the amount of waste that remains. The more waste left in landfill, the higher the rate of emissions. Since the establishment of the landfill in 1985, CO₂e emissions of 2,436,535.87 tons have been produced. So, the average emissions produced per year are 60,913.40 tons of CO₂e/year. If the Gasification WTE plant deemed not yet operational in 2025 and the landfill emissions continue until 2045, then the total CO₂e emissions produced by the landfill are 4,420,774.83 tons, or the average emissions produced per year are **72,471.72** tons of CO₂e/year (see Fig. 6).

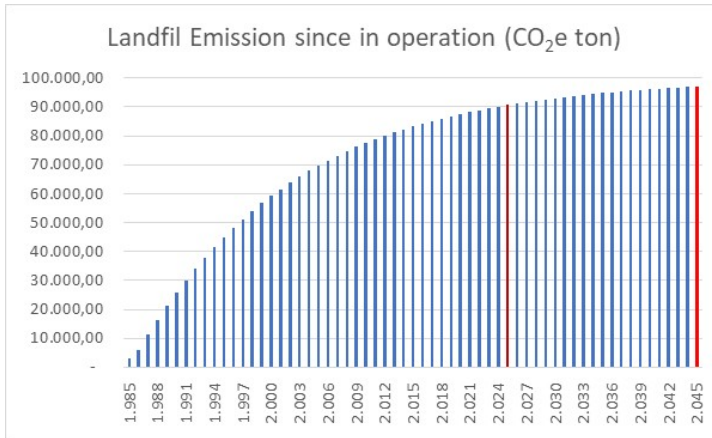

Fig. 6. Landfil Emissions from 1985 to 2045

Furthermore, will be calculated the Emissions produced if the Gasification WTE Project will be build and operate, the project emission are calculated using the Carbon Emission Calculation Method published by the Financial Services Authority in 2024 [10]. which refers to the UNFCCC method. The assumptions and parameters used to calculate carbon emissions from the Gasification WTE Power Plant project are as follows:

Table 8. Assumptions and input parameters for Carbon emission calculation from Gasification WTE project

Category	Type	Value	Unit	Information
Fuels	Diesel	600.0	liters/day	Operation of two unloaders and for EDG
	LPG Gas	36.0	tons/year	Initial heating needs and flare process
Bioenergy		-		
Refrigerants	Refrigerant	1.2	kg/year	Annual AC refrigerants leakage: 10% (IPCC/Defra)
Owned Vehicles	Electric Vehicle	10.0	unit	Vehicles for Operations
	Hybrid Vehicle	7.0	unit	
	Motor	42.0	unit	
	Operator Vehicle	3.0	unit	
	Mobile Delivery	2.0	unit	
	Round Trip	60.0	km	
Electricity Based Location	Electricity from PLN	1.1	Mva	Electrical power for waste processing needs 1.11 MVa

Category	Type	Value	Unit	Information
Heating, cooling, and T&D		-		No external use
WTT-Fuels	Fuel Tank Capacity	6,000.0	liter	Operational fuels
	Duration	10.0	day	
Waste	waste from Operational Day	260.0	tons/year	Daily waste from operations
Water	Water Needs	241.2	m3/day	Gas conditioning, absorption chiller, cooling tower
Material Use	Total Material Use	1,352.0	ton	Materials for construction, operation, and maintenance
Flight and Accommodation	Number of trips	4.0	man/month	Business trips
Business Travel	Day trip	3.0	day	
Freighting Goods	During construction	600.0	ton	Goods for construction
Employees Commuting	Total number of Employees	70.0	people	Daily operation worker
Food				
Home Office	Work from Office	100%		

The above assumption data was processed using the OJK Carbon Emission Calculation Method, so that the results of the carbon emission calculation of the Gasification WTE project with a total emission of 8,572.95 tons of CO₂ were obtained.

Table 9. Calculation of carbon emissions from the gasification WTE project

Project WTE Gasification - 2025 GHG Emissions Report				
Category	Emission Source Category		tCO ₂ e	
GHG Protocol Standards: Corporate - Scope 1 and 2, Value Chain - Scope 3	Scope 1	Direct emissions arising from owned or controlled stationary sources that use fossil fuels	Fuels	799.12
			Bioenergy	-
			Refrigerants	2.31
		Direct emissions arising from owned or controlled mobile sources	Passenger Vehicles	388.54
			Delivery Vehicles	4.33
	Total Scope 1			1,194.30
	Scope 2	Location-based emissions from the generation of purchased electricity, heat, steam, or cooling	Electricity	5,730.87
Heat and steam			-	
Electricity for EVs			14.24	

		District cooling	-
		Total Scope 2	5,745.11
Scope 3	Fuel and energy-related activities	All other fuel and energy-related activities	1.81
		Transmission and distribution losses	118.46
	Waste generated in operations	Waste water	13.23
		Waste	85.53
	Purchased goods	Water supplied	15.55
		Material Use	1,032.63
	Business travel	All transportation by air	5.23
		Emissions arising from hotel accommodation associated with business travel	8.02
		All transportation by sea	-
		All transportation by land, public transport, rented/leased vehicle and taxi	3.33
	Upstream transportation and distribution	Freighting goods	166.49
		Employees commuting	39.99
		Food	139.02
		Home office	4.25
		Total Scope 3	1,633.54
	Total Emissions	8,572.95	

From the calculation of baseline emissions of 72,471.72 tonCO₂e/year and project emissions of 8,572.95 tonCO₂e/year, a reduction in carbon emissions of **63,898.77** tonCO₂e/year will be obtained if the waste gasification power plant will be used to replace the waste disposal method at landfills.

3.5 Technical vs Economical vs Environmental Insights

The gasification process was simulated using Aspen Plus based on municipal solid waste (MSW) from Surakarta, with Equivalence Ratios (ER) of 0.23, 0.30, and 0.40. The technical results showed that ER 0.23 produced the highest quality syngas, with CO at 16.59%, H₂ at 13.61%, CH₄ at 1.58%, and an LHV of 4.36 MJ/Nm³—closely aligning with actual commissioning data from the Surakarta WTE plant. Performance indicators such as Cold Gas Efficiency (CGE) reached 82.22%, Carbon Conversion Rate (CCR) stayed around 80%, and Syngas Production Rate (SPR) increased with higher ER, though at the cost of energy content. Sensitivity analysis confirmed that

lower air and higher oxygen ratios favor CO and H₂ formation, reinforcing ER 0.23 as the optimal condition.

From the economic perspective, the total project cost was estimated at USD 22.92 million, and the financial model yielded a positive NPV of USD 8.58 million, IRR on equity of 12.31%, and a payback period of 7.57 years, indicating financial feasibility. However, sensitivity analysis showed that the project's viability is sensitive to increases in capital cost or reductions in tariff and capacity factor. Incorporating tipping fee income (USD 15/ton) or carbon credit revenue (USD 2/ton CO_{2e}) significantly improved financial returns.

Environmentally, the gasification project offers a major benefit by reducing carbon emissions by 63,898.77 tons CO_{2e}/year, compared to baseline landfill emissions. This significant reduction is attributed to methane avoidance and more controlled carbon release, positioning the project as a viable solution for both clean energy generation and climate mitigation.

This study presents a comprehensive process simulation of a gasification-based WTE system. However, several limitations should be acknowledged. First, the Aspen Plus simulation relies on literature-based kinetic models and assumes ideal operating conditions, which may differ from actual plant performance. Second, the model assumes homogenous waste input, while municipal solid waste exhibits significant heterogeneity that can affect process efficiency. Third, while the economic model includes sensitivity analysis, it assumes static values for tipping fees, carbon credits, and tariffs, which are subject to regulatory and market changes. Lastly, the environmental impact assessment focuses solely on carbon emissions, without evaluating other pollutants or by-products.

These limitations provide directions for future research, including pilot-scale experimental validation, real-time data acquisition, and broader environmental lifecycle assessments. For future research, it is recommended to develop a more detailed carbon emission assessment by categorizing emission sources based on the project's life cycle stages. Emissions should be grouped into three primary sources: electricity use, diesel fuel consumption, and materials and construction. Electricity-related emissions (Scope 2) arise from the use of grid power during operations, such as in syngas cooling, gas cleaning, and waste pretreatment systems. It is important to assume grid emission factors based on national or regional averages to reflect local energy mixes. Diesel fuel emissions (Scope 1) originate from on-site machinery, transportation of waste, and backup power generators; emission factors should follow IPCC or local environmental agency guidelines. Emissions from materials and construction activities (Scope 3) include embedded carbon in concrete, steel, and equipment used during EPC phases. Justifications for each emission source must be supported by activity data, engineering design specifications, or national inventories to ensure accuracy and transparency. Incorporating this level of detail will enhance the robustness of the environmental impact assessment and enable the project to align more closely with international climate reporting standards.

4 Conclusion

The process of gasification of waste into electricity was simulated using Aspen Plus software using proximate and ultimate waste analysis data from Surakarta cities in Indonesia, using a combination of air and oxygen gasifying agents with equivalent ratios (ER) of 0.23, 0.30 and 0.40. From the results of the simulation, it was obtained that the highest value of combustible gas was obtained from the gasification simulation of ER 0.23 with a CO composition of 16.59%, CH₄ 1.53% and H₂ 12.92% and LHV 4.36 MJ/m³.

The highest cold gas efficiency (CGE) gasification performance analysis was obtained from the simulation of ER gasification 0.23 with a value of 81.15%, while the carbon conversion rate (CCR) was in the range of 79.76%, and the syngas production rate (SPR) was 4.20 (Nm³/kg_{waste}).

The economic review concluded that with a total investment of 22.92 million USD for waste gasification of 345.6 tons/day which produces electricity of 5 MW, capacity factor (CF) of 80% and electricity tariff of 13.35 cUSD/kWh; The results of the financial analysis were obtained from the IRR Project 11.41%, IRR Equity 10.23%, Payback Period 7.82 years and DSCR 1.29. If the revenue is added with the potential carbon credit of 2 USD/tonCO_{2e}, it will result in an IRR Project of 10.67% while the tipping fee income of 15 USD/ton will result in an IRR Project of 13.53%.

Baseline emissions are calculated using the Intergovernmental Panel on Climate Change: 2019 Refinement to the 2006 IPCC Guidelines for National Greenhouse Gas Inventories, where the calculation of tier 3 emissions produced if waste is dumped in landfills is 72,471.72 tonCO_{2e}/year. Meanwhile, Project Emissions are calculated by the Carbon Emission Calculation Method published by the Financial Services Authority in 2024 which refers to the UNFCCC method. From the results of the calculation of scope 1, 2 and 3 emissions, it was obtained that the total emissions produced if this waste gasification project were built was 8,572.95 tonCO_{2e}/year. So that the potential to reduce carbon emissions of 63,898.77 tonCO_{2e}/year is obtained.

References

1. SIPSN, Sistem Informasi Pengelolaan Sampah Nasional. (2024). Accessed: Jun. 19, 2025. [Online]. Available: <https://sipsn.kemenvh.go.id/sipsn/>
2. Yang, N., Zhang, H., Shao, L.-M., Lü, F., and He, P.-J.: Greenhouse gas emissions during MSW landfilling in China: Influence of waste characteristics and LFG treatment measures. *J. Environ. Manage.*, 129, 510–521, (2013). doi: 10.1016/j.jenvman.2013.08.039.
3. Alao, J.O., et al.: Effects of dumpsite leachate plumes on surface and groundwater and the possible public health risks. *Sci. Total Environ.*, 897, p. 165469, (2023). doi: 10.1016/j.scitotenv.2023.165469.
4. Moreda, G.A., Teklemariyam, D.A., Tolasa, S.D., and Gutata, G.R.: Pyrolysis of Khat waste vs. Coal: Experimental and Aspen plus analysis. *Heliyon*, 10(20), p. e39097, (2024). doi: 10.1016/j.heliyon.2024.e39097.
5. PLN, RENCANA USAHA PENYEDIAAN TENAGA LISTRIK 2025-2034. PT PLN (Persero) (2025). Accessed: Jun. 19, 2025. [Online]. Available: <https://web.pln.co.id/statics/uploads/2025/06/b967d-ruptl-pln-2025-2034-pub-.pdf>
6. Kalogirou, E.N.: Waste-to-Energy Technologies and Global Applications. (2018).

7. Mujiarto, S., Sudarmanta, B., Fansuri, H., and Saleh, A.R.: Comparative Study of Municipal Solid Waste Fuel and Refuse Derived Fuel in the Gasification Process Using Multi Stage Downdraft Gasifier. *Automot. Exp.* 4(2), 97–103 (2021). doi: 10.31603/ae.4625.
8. Catalanotti Elena, Porter Richard T.J., and Mahgerefteh Haroun: An Aspen Plus Kinetic Model for the Gasification of Biomass in a Downdraft Gasifier. *Chem. Eng. Trans.* 92, 679–684, (2022). doi: 10.3303/CET2292114.
9. IPCC: Refinement to the 2006 IPCC Guidelines for National Greenhouse Gas Inventories, vol. 5. Switzerland.: Intergovernmental Panel on Climate Change, (2019).
10. OJK, METODE PERHITUNGAN EMISI KARBON, 1st ed. Otoritas Jasa Keuangan, 2024. Accessed: Jun. 06, 2025. [Online]. Available: https://keuanganberkelanmillionn.ojk.go.id/keuanganberkelanmillionn/BE/uploads/siaranpers/files/file_5123950d-cab1-467a-b2e2-f5560766ebe3-12032024152356.pdf
11. UNFCCC, CDM Methodology Booklet, Fourteenth edition. Bonn, Germany: UNFCCC secretariat, 2022. Accessed: Jun. 09, 2025. [Online]. Available: <https://cdm.unfccc.int/methodologies/>
12. P. SCMPP, “Feasibility Study Surakarta WTE 5 MW,” PT SCMPP, Surakarta, Final Feasibility Study, 2018.
13. Basu, P and Kaushal, P.: Design of biomass gasifiers. In: *Biomass Gasification, Pyrolysis, and Torrefaction*, Elsevier. 259–328.(2024) doi: 10.1016/B978-0-443-13784-6.00012-3.
14. Catalanotti Elena, Porter Richard T.J., Chalchooghi Mazaher Molaei, and Mahgarefteh Haroun: Biomass Gasification in a Downdraft Gasifier with In-situ CO₂ Capture: a Pyrolysis, Oxidation and Reduction Staged Model. *Chem. Eng. Trans* 80, 85–90, (2020), doi: 10.3303/CET2080015.
15. Basu, P. and Kaushal, P.: Gasification theory. In: *Biomass Gasification, Pyrolysis, and Torrefaction*. Elsevier. pp. 207–258. (2024). doi: 10.1016/B978-0-443-13784-6.00008-1.

Open Access This chapter is licensed under the terms of the Creative Commons Attribution-NonCommercial 4.0 International License (<http://creativecommons.org/licenses/by-nc/4.0/>), which permits any noncommercial use, sharing, adaptation, distribution and reproduction in any medium or format, as long as you give appropriate credit to the original author(s) and the source, provide a link to the Creative Commons license and indicate if changes were made.

The images or other third party material in this chapter are included in the chapter's Creative Commons license, unless indicated otherwise in a credit line to the material. If material is not included in the chapter's Creative Commons license and your intended use is not permitted by statutory regulation or exceeds the permitted use, you will need to obtain permission directly from the copyright holder.

