

Application of EDA Technology in Designing of Digital System

Hui Zhao^{1, a}, Yubing Jing^{2, b}

^{1, 2}Zhonghuan information college, Tianjin University of technology, Tianjin, 300380, China

^aemail: tj_zhaohui@163.com, ^bemail: jingyubing@163.com

Keywords: EDA technology; VHDL; CPLD; digital system design

Abstract. EDA is a new technology developed along with the development of the electronic system design technology. This paper firstly introduces the basic characteristic of EDA technology, then took the EDA technology as a development means to realize the design of a digital system, and the system simulation has been realized by EDA development platform Mux+plusII. The results show that the digital system design through EDA technology can greatly simplify the hardware circuit structure, and has the characteristics of high reliability, flexible design.

Introduction

With the rapid development of electronic technology, the trends of digital system design is high speed, large capacity, and small volume, the conventional bottom-up design method has been difficult to adapt to the requirements of electronic system design, therefore, the EDA (Electronic Design Automation) technology had emerged as the times require. EDA takes the computer as working platform, using the EDA software as developing environment, the HDL (Hardware Description Language) as designing language, the PLD (Programmable Logic Device) as the experiment carrier, taking the ASIC (Application Specific Integrated Circuit) chip as the target device, to realize the automation of electronic products design [1][2]. The literature [3] [4] describes the development process of EDA technology, until the 20th century, the 90s, EDA technology has new developed. It is the combination of high-tech electronic technology, computer technology, information processing technology, intelligent technology and the latest achievements and development, is a kind of advanced, quick, efficient electronic design automation tools.

Basic Characteristics of EDA Technology

EDA technology represents the latest development direction of electronic design technology, its basic characteristics are using the top-down design method, firstly, the whole system was divided into various functional modules, then using hardware description language to complete the design of each functional module, and finally realize the design of the whole system, and through the synthesizer and adapter generates the final target device [5]. The following introducing a few concepts about EDA basic characteristic.

(1) Top-down design method

EDA technology provides a top-down design method. This design method according to the general requirements of the system, top-down design content are gradually refined, and finally to complete the overall design of the system hardware. Because the main design simulation and debugging process is completed at a high level, this is not only conducive to the early discovery of structure design errors, avoid the waste of design work, but also reduce the logic function simulation workload, improve the one-time success rate of design.

(2) VHDL

VHDL (Very high speed integrated circuit Hardware Description Language) is a full range of hardware description language, it uses software programming way to describe the hardware logical function, structure and connection form, it includes the system behavior, register transfer level and logic gate level multiple design level, and supports structure, data flow, behavior, three kinds of mixed description, almost covered various functions of different versions hardware description

language, both the top-down or bottom-up circuit design can be accomplished with VHDL. In the area of electronic design engineering, it undertook the design task almost all digital system, and the design is more suitable for large scale digital systems.

(3) CPLD

PLD is a new of logic device programmed by the user to achieve a certain logic function [6]. Ever since the emergence in the 20th century the 70s, the PLD has gone through PAL, GAL, CPLD, FPGA (Field Programmable Gate Array) several stages of development. The CPLD/FPGA belongs to high density programmable logic device, the current integration level has reached as high as 2 million gates one chip, it has advantages of fast speed, high integration, encryption, repeatedly download, and has been widely used. CPLD/FPGA devices have become a carrier of realizing the modern advanced electronic system design.

Designing of Digital System based on EDA Technology

The designing of a responder system based on EDA technology has been introduced in this paper, the design uses the hierarchical method, and the top level schematic document of responder is shown in Figure 1. The whole system is divided into five modules: RD (Responder Discriminant) module, CD (countdown) module, DEC (Decoding Display) module, FD (frequency divider) module, BELL (loudspeaker control) module. The function of each module is described using VHDL, then the correct simulation results are realized at the integrated development environment Max+Plus II.

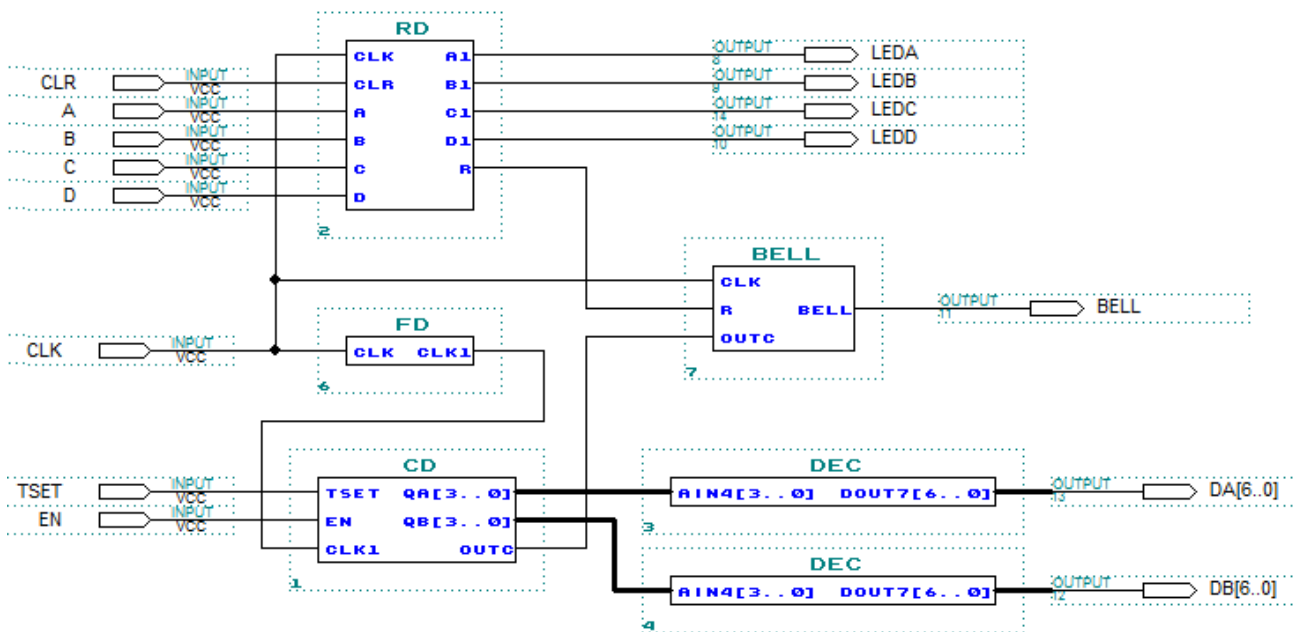

Fig.1. Top level schematic document of responder

The responder has four road input, the device can identify the signal of the first responder, and shows that the set of signals, and the time is countdown displayed while answer question, timeout alarm, and has a reset function, countdown start function.

Responder Input signal has responder button A, B, C, D, a reset signal CLR, a clock signal CLK, timer enable end EN, the countdown time preset signal TSET. The output signal of the system has four group responder success control signal output port LEDA, LEDB, LEDC, LEDD, the countdown time to end alarm signal BELL, countdown display decoder output signal DA[6..0], DB[6..0].

The design uses the modular design method. Firstly, writing VHDL code to describe each module circuit function, then creating the top level schematic diagram. Design input, compiled, logic synthesise and function simulation are accomplished through Mux+plusII. In the end, the design result will be downloaded to the CPLD chip, and completed the connection of hardware circuit.

(1) Design of responder discriminant module

Responder input button is A, B, C, D, active high. The reset signal is CLR, active high. When CLR is high level, responder discriminant circuit is reset, and ready for the first vies to answer first signal discrimination. When a group of input signal responder success, the corresponding output A1, B1, C1, D1 is high level, and these output port is connected to the indicator light through LEDA, LEDB, LEDC, LEDD, so as to display the result, at the same time, the output end of R is the high level, R is connected to the input of the BELL module, to control the output of the BELL generates high level alarm signal, indicate the responder successful. Simulation of responder discriminant module is shown in figure 2.

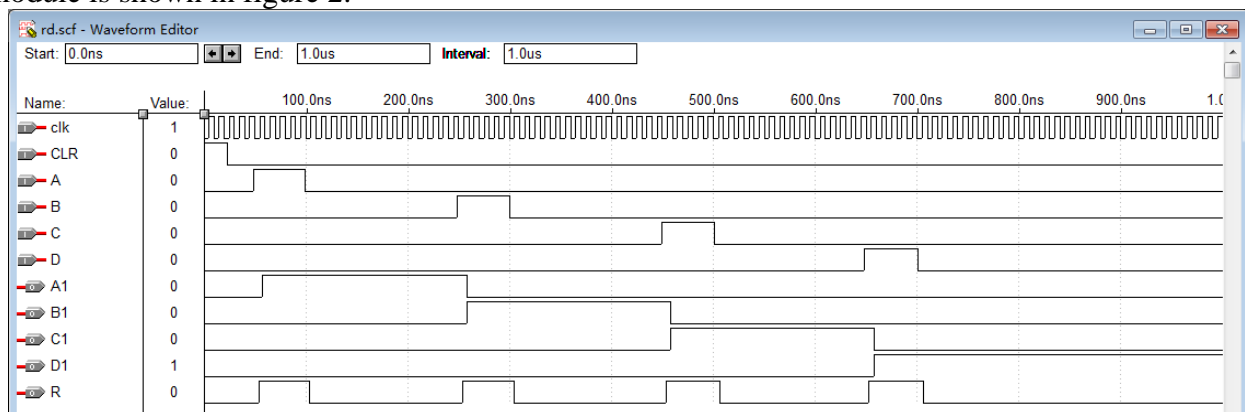

Fig.2. Simulation of responder discriminant module

(2) Design of countdown module

The countdown circuit not only has a preset initial value function, but also has count reduction function. TSET is the preset port of initial value, CLK1 is the input port of pulse per second, EN is counting enable control terminal. The module has two set of four bits BCD (Binary Coded Decimal) code output port, when arrival to the countdown to the end of time, the output end of OUTC is the high level, it is connected to the loudspeaker control circuit, and sends a corresponding alarm. Simulation of countdown module is shown in figure 3.

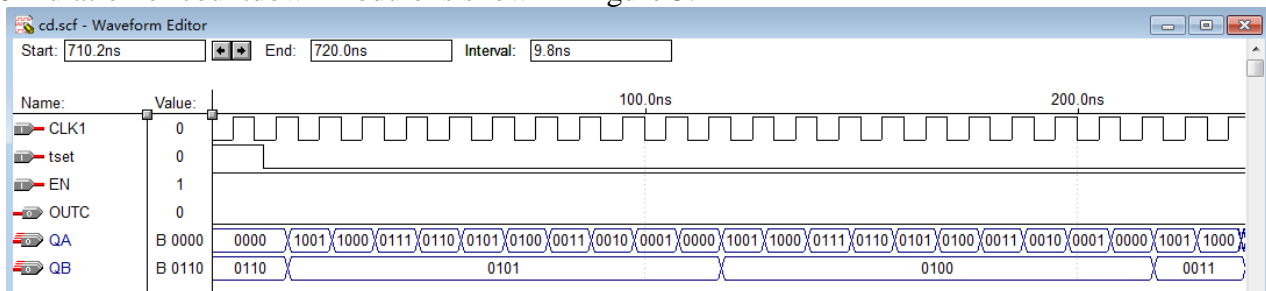

Fig.3. Simulation of countdown module

Conclusion

A responder system design adopts EDA technology, uses hierarchical top-down design method, uses the software of Mux+plusII with the mixed input methods, uses VHDL to describe each module circuit function, and then creates the top level schematic diagram through a graphic editor file, design hierarchy clear. The hardware designing of responder system adopts CPLD chip, reducing the complexity of the hardware circuit, and has characteristics of low power consumption, high reliability. By modifying the VHDL program can modify the design conveniently, so the design of digital system is more flexible, efficient, and has good application prospects.

References

[1] Ye Jiazhao, Lu Bin, Cheng Dong. Discussion on digital circuits practical teaching based on EDA technology [J]. Experimental Technology and Management. 2010 27 (11) 249-252.

- [2] Hu Haoran, Wu Jia-ni, Zhang Fei. Hardware design of independent experimental platform based on FPGA[C]. Proceeding of 2010 Second International Conference on Communication Systems, Networks and Applications. Hubei: [s. n.], 2010. 44-47.
- [3] QI Hai-bing. Application of EDA Technology on Professional Teaching for Electronic Information Engineering[C]. Proceedings of 2010 International Conference on E-Health Networking, Digital Ecosystems and Technologies. Hubei: [s. n.], 2010: 203-206.
- [4] SCHEFFER Louis, LAVAGNO Luciano, MARTIN Grant. EDA for IC System Design, Verification, and Testing[M]. U.S.A. Florida: CRC Press, 2006.
- [5] Hou Boheng, Liu Kai, Gu Xin. The VHDL hardware description language and digital logic circuit design of [M]. Xi'an: Xi'an Electronic and Science University press, 2009.
- [6] Liu Jianghai, Tu Chuanwei, Guo Songmei. EDA technology [M]. Wuhan: Huazhong University of Science and Technology press, 2009.