

Research on Mechanical Product Design System Based on C-K Theory

Qinzhou NIU, Weiyuan ZHOU, Chenyun DENG, Yucheng DU, Mengda CHEN

College of Mechanical and Control Engineering, Guilin University of Technology, Guilin, 541004, China

Keywords: C-K Theory; Variant Design; Guidance Model; Parameterization; Modeling Rules

Abstract. In the machine tool manufacturing industry, most of the design is based on previous resources, in terms of similar structure; the traditional mechanical design takes the approach of repeated modeling, but this approach greatly limits the scope of the personnel involved in design activities. It costs a lot of labor in almost identical work. In response to this situation, this paper introduces C-K design theory, combined advanced design guideline and mechanical design process. Take the existing design rules, constraints, characteristics of models as available knowledge of knowledge space in C-K theory, and the initial structure created by design requirements and available knowledge of knowledge space as the initial concept of concept space. Expand concept space and knowledge space with the dividing, learning and reasoning in order to provide more available knowledge for serial design activities. The mechanical product rapid design system is developed on the Solidworks, and it will increase the reuse rate of enterprise resources, reduce the error rate in design activities, improve the product quality, and shorten the production cycle.

Introduction

The current variant design method is much more simple, most of them use the existing knowledge base (i.e. a large number of available samples in variant design system), which makes the new concept and new knowledge can not generate, knowledge base and design concept can't be extended, and design method will also have some limitations[5]. Therefore, we apply C-K innovative design theory to mechanical design process in this paper. Take the initial structure created by design requirements and available knowledge of knowledge space as the initial concept of concept space in C-K theory. And the knowledge accumulated in the process of produce and design (including design drawings, production equipment, experience, rules and regulations, etc.) as available knowledge of knowledge space in C-K theory. The available knowledge is the base to produce innovative in mechanical design or produce process. At present, domestic and foreign scholars have done a lot of research in variant design [3], and have made some achievements, but researches on variant design method based on C-K theory still rarely seen, so this research has some objective economic and academic value.

C-K Theory

C-K theory is first proposed by Hatchuel and Weil in 2003[1], whose aim is to provide a rigorous, unified theory for design. C-K theory describes an assumption that design can be described as a process of interaction between concept space and knowledge space with different logic and structure. The existing design guideline and design theory define design as a dynamic mapping of the needs of function and selected architecture. But this dynamic mapping is not sufficient to describe the new objects and knowledge which have different characteristics generating in the design process. C-K theory can accurately capture the property of newly generating objects, and provide a strict definition for design. The structure and interaction of concept space and knowledge space reflect the core idea of C-K theory.

2.1 Constituent elements of C-K Theory

(1) Knowledge space (K space) K space is a set of several propositions which describe some of these objects are known, and these propositions with defined logic status. The logic status of all propositions in K space is determined, and K space is extensible. In practice, the logic status of

propositions has been determined and these propositions are effective knowledge set for designer or the design team.

(2) Concept space (C space) C space is a set of propositions whose logic status is neither true nor false, which may come from technology or market demand, and there is not yet a satisfactory solution. Therefore, it is particularly necessary to meet this demand by a variety of innovative development tools or theory. Assumes exiting a proposition P: "there are several objects, with a series of properties: A_1, A_2, \dots, A_n which all are true in K", and related to K, the logic status of P is uncertain, then proposition P is a concept related to K, whose entirety called concept space i.e. space, C space is the precondition of C-K theory, and is the key to make new object generate in the design process. C space is also extensible.

2.2 The description of C-K theory in the design process [2]

In C-K design theory, the process begins with an initial design concept C_0 , which clearly and accurately represent an object which is not entirely known, and with desired properties. Assuming concept space C: "Existing an object X with attributes A_0 ". By increasing or reducing properties and introducing part design parameter D_i , then initial property A_0 becomes A_i . In this process, has created a new proposition C_i from the initial C_0 , namely: "Existing an object X, having a set of attributes A_i , and the attribute A_i composed by a series of design parameters D_i ". Then in the knowledge space, the logic status of C_i has following three possibilities:

- (1) C_i in K is false, and then the design process must change some A_i or D_i ;
- (2) C_i in K is true, then (A_i, D) solution is one of the candidate solutions of X, known as example X;
- (3) C_i is uncertainty in K, which means it is neither true nor false, and then C_i is a new concept; the design process will be continued.

In the cases of (1) and (2), C_i is a proposition whose logic status has been determined, and it will be added to K space to become new knowledge; In the 3rd case, C_i isn't a determined proposition, and C_i will be added to C space as a new concept. After judging the logic status of C_i , the next step in the design process it's:

- (1) In the case of C_i is false, cancel the increase or decrease of property A_i or parameter D_i in this step, return to the previous step, reselect property A_i or parameter D_i to change, in order to continue the design process;
- (2) In the case of C_i is true, (A_i, D_i) will be listed in the candidate solutions, the design process is finished in this step;
- (3) In the case of C_i is the new generated concept, on the basis of increase or decrease property A_i or parameter D_i , continues the design process.

In summary, C-K theory in the design process not only generates "solution", also generates new concepts and new knowledge in the same process.

More strictly speaking, the design process should be described as bilateral extension of C space and K space. Concept can be expressed as a set of properties of one or more entity objects, design will be simplified as known knowledge in the past without the existing of concept. In the design process, the concept generates the other concepts, or converted to knowledge, i.e. proposition in K space.

2.3 Conversion relations and structural of C-K model

C-K theory achieves the expansion of two spaces between themselves and with each other through interaction of two structurally different internal and external spaces. This includes four different operators, $C \rightarrow C$ and $K \rightarrow K$ know as internal operator, and $C \rightarrow K$ and $K \rightarrow C$ which is called external operator.

(1) Conjunction ($C \rightarrow K$) The operator search properties in the knowledge space and these properties can be added or reduced to the proposition whose logic state has been known. Namely, after a concept verified in reality, it will leave the "concept space" into "knowledge space" as a part of its extension, and those concepts which come from extension but has not yet been verified will continue remaining in concept space. The operator produces a "conjunctive proposition", which can be understood as "the design has been finished."

(2) Disjunction ($K \rightarrow C$) The operator to add or reduce some attributes from the K space, resulting in a "disjunctive proposition", to form a new concept. In the operator, expands the concept of space through the elements in the knowledge space.

(3) Partition || Inclusion ($C \rightarrow C$) The new concept is derived and multi-variation generated from the original concept can coexist in the concept space. The operator refines the initial concept by further increases known attributes in K space; the segmentation of split type is segmentation and extensibility. The operator is an important operator to form the process and results of C-K.

(4) Experiment || Deduction ($K \rightarrow K$) The operator includes all classic type of reasoning (deductive, experiment, reasoning), through combination with other knowledge or blend in recent discoveries, to create new knowledge. This process is particularly important for research and development activities. The interaction of C space and K space is available as shown in figure 1 the "Design rectangle":

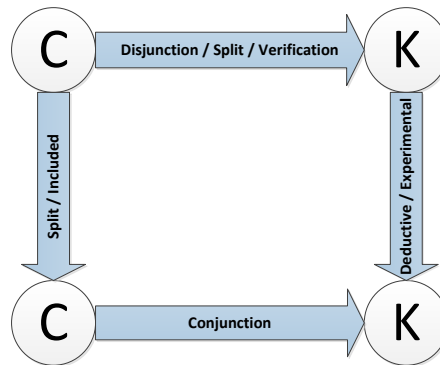

Fig.1 C-K theory "Design Rectangle"

Proposition in Space C can not be "search" and "query", it is obtained by refining, therefore the concept of the space C is a tree structure, which is not a decomposition, but a combination of diverging extension. The proposition in space K has separate individual logic, whose structure is independent, and there is no definite link between each other. Therefore, the structure of C-K theory is a left-right asymmetry of the structure [7]. The structure shown in Figure 2:

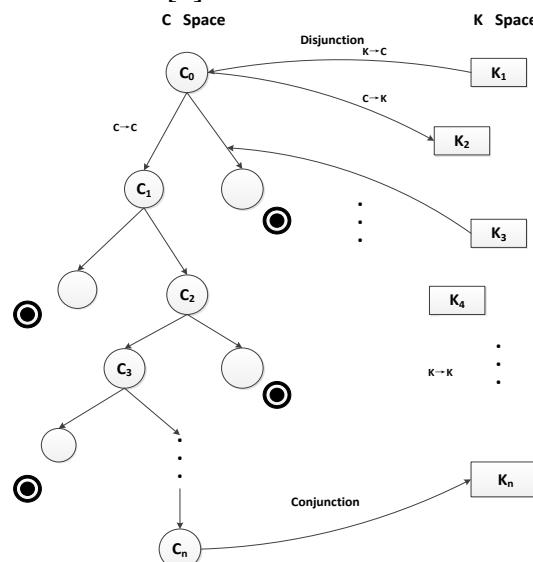

Fig.2 C-K theory structure

As can be seen from the figure, the concept space is a root node of the tree structure C_0 , but knowledge space structure is totally different from concept space, these two spaces appear as an asymmetric structure form. In the figure, any expansion in C is associated with K; the following concepts are refined and extended from initial concept. Similarly, some of the extensions in K are also required C. Eventually, the entire design end with a conjunctive proposition, and ultimately converse into knowledge, we said design get a satisfactory solution.

C-K theory integrated with parameterization and variant design

Take the existing grinder model as the initial knowledge of C-K theory, which contains various components used in the expression characteristics, constraints (not necessarily complete), the basic parameters of knowledge and information, this completes the extraction and the establishment of knowledge base. And take the requirement which the grinder factory propose as the initial concept of C-K theory, then we complete the establishment of initial concept. Large functional parts of grinder belong to part level, as shown in Table 1 is parts classification based on parameterization.

Table1 Parts classification based on parameterization

Part Type	Parametric rate
Functional pieces	High
Assembly pieces	Slightly higher
Auxiliary pieces	Low

Grinding machine table parameterized modeling, for example, according to the size of the effects of various parameters on grinding machine processing capacity, conforms the driving and driven parameters, as shown in table 2.

Table2 Driving and driven parameters of table

Driving Parameters	Table length	Table width
Driven Parameters	Guide length	T-slot size
	Guide width	Guide span

C-K theory integrated with table parametric modeling shown in Figure 3:

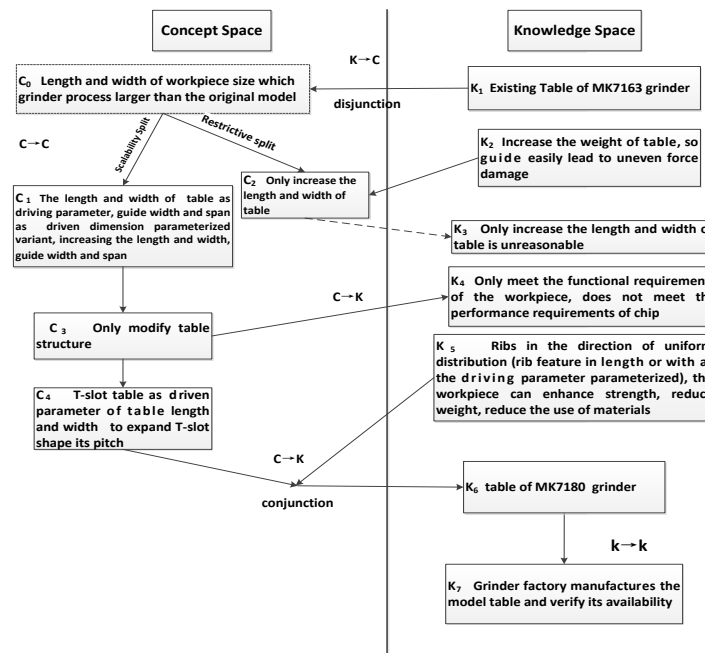

Fig. 3 C-K theory with table parametric modeling

As shown in Figure 3, in the process of part level parametric variations, take the table of MK7163 grinder as available existing knowledge, disjunctives grinder table with new function, achieves the conversion of $K \rightarrow C$ (knowledge to concept); Through refining the table with new function, this concept has been divided and scalability constraints of segmentation, achieves the extension of $C \rightarrow C$ (concept to table concept); Through conjunctives C_4 and K_5 , achieves $C \rightarrow K$, i.e. the design process of concept converses to knowledge, then get a design solution; Finally, verifies the design solution by experiment, to achieve $K \rightarrow K$ --the internal expansion of knowledge space, besides, stores the new knowledge, to provide new knowledge available for future design activities, this constitutes a complete four operators of C-K design theory.

Realization of System Function

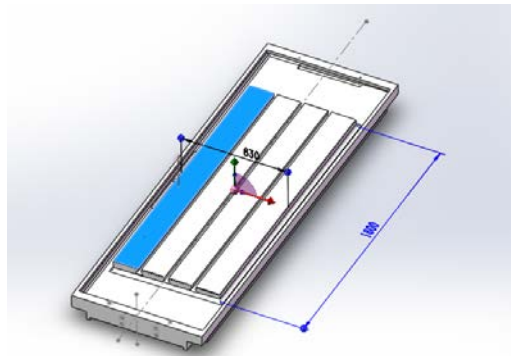

Fig. 4 table of MK7163 grinder

Using the table of grinder as an example, whose driving dimensions include the length and with of table, driven dimensions include length and with of guide, T-slot size and guide span, etc. Some examples of grinder parametric variations shown in Figure 5:

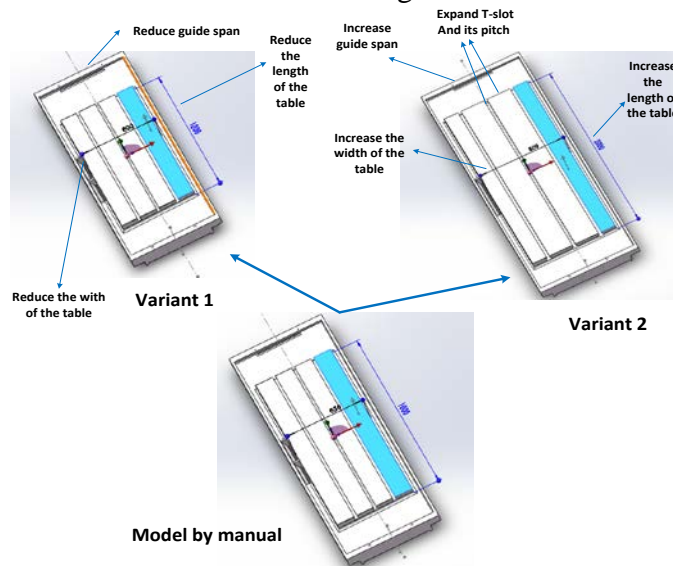

Fig. 5 a fragment of table parametric variations



Fig.6 some parameterized scripts written in the relationship

This system is derived from secondary development of Solidworks; the system uses the overall framework for Delphi, VBS as an embedded script package provided by Solidworks API functions to drive the model parameterized.

The concrete application of rapid design system is as follows. Firstly, make some type of grinder whose all parts support parametric modeling been imported or copied to stored to the specified

folder. Then start the system to select the parameters of variant parts, analyze, read features of the model, and determine the driving parameters and driven parameters. The 3rd step is to specify the driving parameters and driven parameters, and read the specific values corresponding to the feature. The fourth step is based on the characteristic expression, and edits the script to calculate and confirm the relationship. Script writing relationship is the key to parametric variations[4], especially for some of the characteristics on the driving parameter direction can not take the whole number, you should add int or round function depending on the actual situation, part of the script editor shown in Figure 6. Finally, experimental verification or simulation analysis the models after parametric variant, if they meet the design requirements, then store them into the knowledge base, to use for later design.

Conclusion

In order to improve the machine tool industry in the design process, improve the existing similar models modeling speed, and improving the utilization of available resources, the paper developed a rapid design tools system based on C-K theory. The proposition of C-K theory combined with parametric variant design method, effectively improves the speed of the enterprise for the product modeling, improve the production efficiency. C-K theory has little research domestic, so in this paper we describe C-K theory in detail. In this paper, the work of the research belongs to the frontier of manufacturing informatization basic research, to promote and implement manufacturing informatization, improve the level of production and the design of Chinese manufacturing industry will play a very important role. Of course, there are still some deficiencies. Such as: automatic assembly equipment and accessories seamlessly switch between different CAD systems and platforms are research goals in the future.

References

- [1] Hatchuel, A. and Weil, B. August, 2003. A new approach of innovative design: an introduction to C-K theory. International Conference on Engineering Design, Stockholm, 19-21.
- [2] Hatchuel, A. and Weil, B. 2008. C-K design theory: an advanced formulation. Research in Engineering Design, 19(4), 181-192.
- [3] Hatchuel, A. and Weil, B. 2009. C-K design theory: an advanced formulation [J]. Research in Engineering Design, 19 (4):181-192.
- [4] Qian Xiaoming, Wang Ningsheng. 2003. Studies support the rapid variant design of the product model [J]. Mechanical Science and Technology, 22 (4): 670-674.
- [5] Qu Yuanju. 2013. Research on variant design size constraints and parametric passing [D] Shenyang: Shenyang University of Technology.
- [6] Qi Congqian, CUI Qiongyao. 2002. Research on design method based on parametric technology. [J]. Machine Design and Research, (5): 13 ~ 15.
- [7] YANG Shaoxian, PI Chenggong, JIA Xiaoman. 4, 2014. Research on dual-use technology and product innovation based on C-K theory [J]. Science and Technology Progress and Policy, Vol.31 NO.18.