

Research and Development on Series of LNG Plate-fin Heat Exchanger

Zhouwei Zhang^{1, 3, a}, Yahong Wang^{2, 3, b}, Yue Li^{1, c} and Jiaxing Xue^{1, d}

¹School of Environment and Municipal Engineering, Lanzhou Jiaotong University, Lanzhou 730070, China

²School of Mechanical and Electrical Engineering, Lanzhou Jiaotong University, Lanzhou 730070, China

³Gansu Zhongyuan Energy and Power Engineering Co.,Ltd.,Lanzhou 730070, China

^azhangzwemail@126.com, ^b0701wangyahong@163.com, ^c287794330@qq.com, ^d316221260@qq.com

Keywords: Plate-fin heat exchanger; LNG; Mixed refrigerant; Plate bundle

Abstract: The research and development situations of LNG plate-fin heat exchanger (LPFHE) were discussed in view of heat exchange in LNG field in petrol-chemical industry. The basic designing methods and the multi-stream heat exchange processes were illustrated by the cryogenic and high pressure cross heat exchange equipments of LPFHE with multi-stream and multiphase flow, including *Five-stream LPFHE in first stage, Four-stream LPFHE in second stage, Three-stream LPFHE in third stage, Multi-stream main LPFHE* etc. A series of LPFHE with different mixed refrigerants and different applications were described. The plate arranging structure characteristics and the working principles of the plate bundles were elaborated to give references for the scientific design and calculation of LPFHE in cryogenic field. The major research directions and the critical scientific problems were forecasted.

Introduction

LNG plate-fin heat exchanger (LPFHE) is mainly used in natural gas liquefaction field, including *Five-stream LPFHE in first stage* [1], *Four-stream LPFHE in second stage* [2], *Three-stream LPFHE in third stage* [3], *Multi-stream main LPFHE* [4] etc., with phase-changed refrigeration and multi-stream of cryogenic and high pressure heat exchanger due to different liquefaction process and shape design. LPFHE mainly involves multi-stream heat exchange of mixed refrigerant in LNG cryogenic liquefaction and throttling refrigeration technology with mixed refrigerant, i.e., N₂, CH₄, C₂H₄, C₃H₈, C₄H₁₀ and I-C₄H₁₀ in the LPFHE, which make 36 °C and 6.1 MPa natural gas gradually cooled to -164 °C and liquefied and super-cooled by the multi-stage refrigeration. The LNG liquefaction process of LPFHE mainly includes three stages with mixed refrigerant. The compressed natural gas is pre-cooled from 36 °C to -53 °C in the first stage, from -53 °C to -120 °C in the second stage for liquefaction preparation, -120 °C to -164 °C in third stage for entirely liquefaction. Three processes can use different cooling process, different refrigerant and heat exchange equipment. In order to reduce the number of heat exchangers in LNG liquefaction system, reduce the cryogenic insulation area, be convenient for maintenance and heat exchange, the three sections of the main heat exchangers can be connected together as a whole LNG liquefaction unit. Prolong heat exchanger height to 20 ~ 30 m, the natural gas can be directly liquefied from 36 °C to -164 °C and super-cooled through a complete LPFHE, heat exchange efficiency can be obviously improved, and management process can be more convenient.

According to the LNG liquefaction features about mixed refrigerant, apply sectioned refrigeration method with different refrigerant, in view of N₂, CH₄, C₂H₄, C₃H₈, C₄H₁₀, I-C₄H₁₀ refrigeration technology, LPFHE was researched and developed in the range of 36 °C ~ -53 °C, -53 °C ~ -120 °C, -120 °C ~ -164 °C to solve the difficult problem of LNG cryogenic liquefaction process with multi-stream heat exchange and mixed refrigerant refrigeration technology. LPFHE involves cryogenic heat exchange of mixed refrigerant with multi-phase, multi-stream, back-heating and multi-stream throttling refrigeration of mixed refrigerant. It is one of the most complicated and difficult heat

exchanger in designing, calculating and manufacturing. It also has no universal design method, no unified calculation method, no standards, and need to re-calculate refrigerating capacity and ascertain the refrigerant mixture ratio before designing. With the greater difference of process characteristics or physical parameters, there has the greater structural difference and it is difficult to be standardized. In addition, for the more plate arranging methods of multi-stream plate bundles, there has no unified plate arranging type, theoretical designing model and calculating method for computer aided calculation, and it brings the obstacle to scientific calculation of LPFHE heat exchange.

Since 1980's in last century, APCI and Linde developed LPFHE and used it in LNG plant to solve the problem of multi-stream cryogenic heat exchange in high pressure back-refrigeration process with the higher efficiency and intensity. The natural gas can be liquefied in LPFHE directly. In China, the heat transfer mechanism [5] of multi-stream and multi-phase flow in LPFHE is researched deeply by LI Yanzhong team in Xi'an Jiaotong University since 1980s, and many papers published at home and abroad [6]. Based on its achievement, the multi-stream heat exchangers was researched systematically by Lanzhou Jiaotong University and Gansu Zhongyuan Energy and Power Engineering Co., Ltd., such as $-163\text{ }^{\circ}\text{C}$ LPFHE used in LNG plant [1~4], $-163\text{ }^{\circ}\text{C}$ multi-stream coil wound heat exchanger used in LNG plant [7~10], $-63\text{ }^{\circ}\text{C}$ multi-stream heat exchanger used in rectisol plant [11~13] and $-197\text{ }^{\circ}\text{C}$ multi-stream heat exchanger used in liquid nitrogen washing plant [14~15]. According to the different temperatures and application fields, the different calculation methods were studied [16~17] for different working conditions, and the design criteria has been creating for multi-stream heat exchanger. Aiming at $-164\text{ }^{\circ}\text{C}$ multi-stream heat transfer characteristics and structure features of series of LPFHE, based on the development of LPFHE with *Five-stream LPFHE in first stage, Four-stream LPFHE in second stage, Three-stream LPFHE in third stage, Multi-stream main LPFHE* and other multi-stream, multi-phase and cryogenic heat exchanger were researched and currently the industrial designing and manufacturing capability was greatly developed.

Five-stream LPFHE in first stage

Structure design and heat transfer process

The five-stream LPFHE in first stage (Fig. 1a) is mainly comprised of 37 components, such as the plates, the folded plates and the comprised channels etc., of which four channels share for the refrigerants and one for natural gas. It mainly uses the mixed refrigerant of N_2 , CH_4 , C_2H_4 , C_3H_8 , C_4H_{10} and $\text{I-C}_4\text{H}_{10}$ pre-cooling the mixed refrigerant of N_2 - CH_4 - C_2H_4 and natural gas to $-53\text{ }^{\circ}\text{C}$. The mixed refrigerant of C_4H_{10} - $\text{I-C}_4\text{H}_{10}$ of $36\text{ }^{\circ}\text{C}$ and 0.9 MPa is cooled to $-53\text{ }^{\circ}\text{C}$ and 0.6 MPa by the cold-side throttled C_3H_8 , throttled C_4H_{10} - $\text{I-C}_4\text{H}_{10}$ and $-63\text{ }^{\circ}\text{C}$ and 0.3 MPa N_2 - CH_4 - C_2H_4 . Then C_4H_{10} - $\text{I-C}_4\text{H}_{10}$ is throttled and super-cooled to $-52.85\text{ }^{\circ}\text{C}$ and 0.3 MPa , and flows into cold-side channels and mixed with C_3H_8 , N_2 - CH_4 - C_2H_4 , and cools the hot-side nature gas, N_2 - CH_4 - C_2H_4 , C_3H_8 and C_4H_{10} - $\text{I-C}_4\text{H}_{10}$, and finally gets out of five-stream LPFHE at $26\text{ }^{\circ}\text{C}$ and 0.3 MPa . The hot-side refrigerant of C_3H_8 of $36\text{ }^{\circ}\text{C}$ and 2.18 MPa is cooled to $-53\text{ }^{\circ}\text{C}$ and 1.88 MPa by the cold-side mixed refrigerant of N_2 , CH_4 , C_2H_4 , C_3H_8 , C_4H_{10} , $\text{I-C}_4\text{H}_{10}$, then throttled to cold-side and super-cooled to $-52.29\text{ }^{\circ}\text{C}$ and 0.3 MPa , then mixed with the cold-side mixed refrigerant and returns to the compressor with other mixed refrigerant.

Fundamental theory

Firstly, the cryogenic heat transfer process and the overall structure of LPFHE in the first stage of $36\text{ }^{\circ}\text{C} \sim -53\text{ }^{\circ}\text{C}$ were researched and developed, and the refrigeration equipment in first stage was designed, which used C_4H_{10} - $\text{I-C}_4\text{H}_{10}$ and C_3H_8 refrigeration technology providing cold capacity for the first stage. Secondly, using the throttling process of C_4H_{10} - $\text{I-C}_4\text{H}_{10}$ mixed refrigerant, which is pre-cooled to $-53\text{ }^{\circ}\text{C}$ before throttling, can make the first stage refrigeration temperature lowered than its saturated temperature of $-14\text{ }^{\circ}\text{C}$ and $26\text{ }^{\circ}\text{C}$ respectively. Thirdly, using C_3H_8 refrigeration technology can acquire the lower evaporation temperature than C_4H_{10} - $\text{I-C}_4\text{H}_{10}$, namely C_3H_8 can be throttled to 0.3 MPa and $-52.29\text{ }^{\circ}\text{C}$ after being pre-cooled to $-53\text{ }^{\circ}\text{C}$. The three evaporation temperature of $-14\text{ }^{\circ}\text{C}$, $26\text{ }^{\circ}\text{C}$ and $-52.29\text{ }^{\circ}\text{C}$, throttled from C_4H_{10} - $\text{I-C}_4\text{H}_{10}$ and C_3H_8 , can be obtained and it can reduce the entropy

increment in heat transfer process. $N_2-CH_4-C_2H_4$ was pre-cooled and mainly used in refrigeration process for the second and third stage. therefore, there were four-stream flows in hot-side in heat transfer process in first stage.

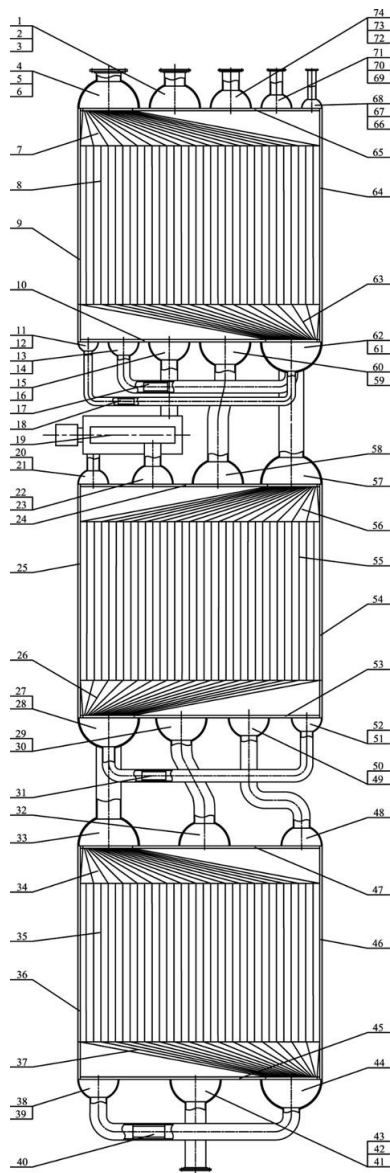
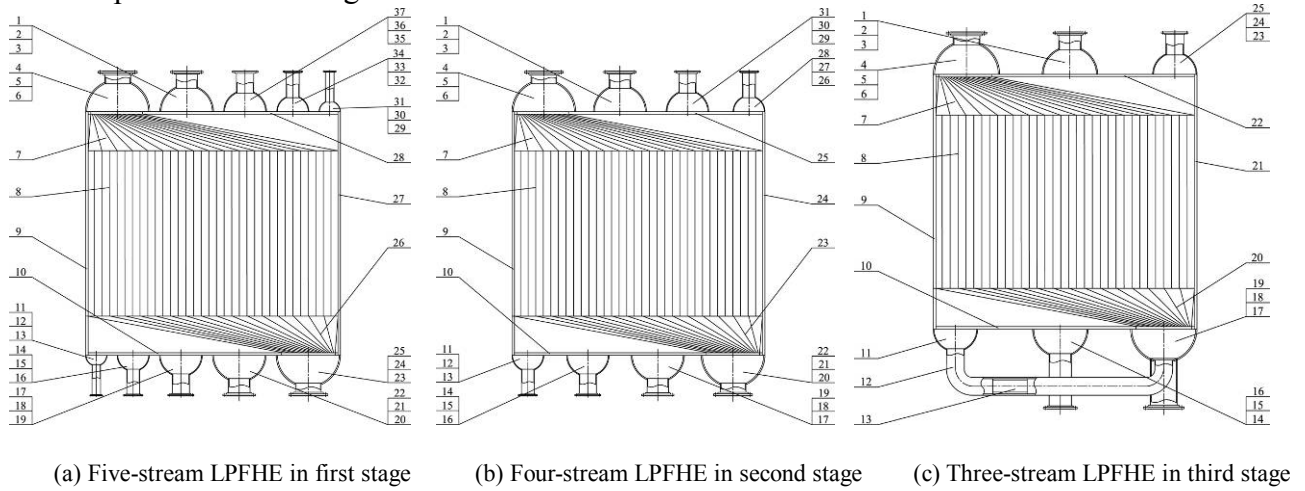

Fig.1. Series of LNG plate-fin heat exchanger

Three-stream LPFHE in second stage

Structure design and heat transfer process

The four-stream LPFHE in second stage (Fig. 1b) is mainly comprised of 31 components, such as the plates, the folded plates and the comprised channels etc., of which three channels share for the refrigerants and one for natural gas. It mainly uses the cold-side mixed refrigerant of N_2 , CH_4 and C_2H_4 pre-cooling the hot-side mixed refrigerant of N_2 - CH_4 , C_2H_4 and natural gas to $-120\text{ }^\circ\text{C}$. The hot-side refrigerant C_2H_4 of $-53\text{ }^\circ\text{C}$ and 1.88 MPa is cooled to $-120\text{ }^\circ\text{C}$ by the throttled C_2H_4 and cold-side $-130\text{ }^\circ\text{C}$ and 0.3 MPa N_2 - CH_4 . Then C_2H_4 is throttled and super-cooled to $-119.4\text{ }^\circ\text{C}$ and 0.3 MPa, and gets into the cold-side and mixed with cold-side N_2 - CH_4 , and cools the plate bundles of nature gas, N_2 - CH_4 and C_2H_4 , and finally gets out of three-stream LPFHE at $-63\text{ }^\circ\text{C}$ and 0.3 MPa. The hot-side N_2 - CH_4 of $-53\text{ }^\circ\text{C}$ and 1.8 MPa is pre-cooled to $-120\text{ }^\circ\text{C}$ by the throttled C_2H_4 and $-130\text{ }^\circ\text{C}$ and 0.3 MPa N_2 - CH_4 in cold-side, then flows into the third stage. Natural gas of $-53\text{ }^\circ\text{C}$ and 5.8 MPa is pre-cooled to $-120\text{ }^\circ\text{C}$ by cold-side N_2 - CH_4 - C_2H_4 , then liquefied and flows out the second stage and enters the third stage.

Fundamental theory

Firstly, the cryogenic heat transfer process and the overall structure of LPFHE in the second stage of $-53\text{ }^\circ\text{C} \sim -120\text{ }^\circ\text{C}$ were researched and developed, and the refrigeration equipment in second stage was designed, which used C_2H_4 refrigeration technology provide cold capacity for the second stage. Secondly, using C_2H_4 throttling process which is pre-cooled to $-120\text{ }^\circ\text{C}$ and liquefied before throttling can provide cold capacity for the second stage. The pre-cooling processes of N_2 - CH_4 , C_2H_4 and natural gas are carried out at the same time, so the four-stream heat transfer process is adopted.

Two-stream LPFHE in third stage

Structure design and heat transfer process

The three-stream LPFHE in third stage (Fig. 1c) is mainly comprised of 25 components, such as the plates, the folded plates and the comprised channels etc., of which two channels share for the refrigerants and one for natural gas. It mainly uses the cold-side mixed refrigerant of N_2 and CH_4 pre-cooling the hot-side mixed refrigerant of N_2 - CH_4 and super-cooling natural gas to $-161\text{ }^\circ\text{C}$. The N_2 - CH_4 of $-120\text{ }^\circ\text{C}$ and 1.58 MPa is cooled to $-164\text{ }^\circ\text{C}$ by the cold-side N_2 and CH_4 and liquefied completely, then throttled to $-185\text{ }^\circ\text{C}$ and $-163.5\text{ }^\circ\text{C}$ in cold-side respectively. Natural gas of $-120\text{ }^\circ\text{C}$ and 5.5 MPa is liquefied entirely by cold-side N_2 and CH_4 to $-164\text{ }^\circ\text{C}$ and 5.3 MPa, then depressurized to 0.1 MPa by the throttle valve and finally flows into the LNG storage tank.

Fundamental theory

Firstly, the cryogenic heat transfer process and the overall structure of LPFHE in the third stage of $-120\text{ }^\circ\text{C} \sim -164\text{ }^\circ\text{C}$ were researched and developed, and the refrigeration equipment in third stage was designed, which used N_2 - CH_4 refrigeration technology to provide cold capacity for the third stage. Secondly, by using throttling technology, N_2 - CH_4 can be pre-cooled to $-164\text{ }^\circ\text{C}$ and liquefied before throttling. The temperature of throttled N_2 and CH_4 reach $-185\text{ }^\circ\text{C}$ and $-163.5\text{ }^\circ\text{C}$ respectively, and the sufficient cold capacity can be obtained for refrigeration in third stage.

Multi-stream main LPFHE

Structure design and heat transfer process

The multi-stream main LPFHE (Fig. 1d) is mainly comprised of three sections illustrated above with 74 major components. It mainly uses the cold-side mixed refrigerant of N_2 , CH_4 , C_2H_4 , C_3H_8 , C_4H_{10} , I - C_4H_{10} pre-cooling the hot-side mixed refrigerant and liquefying natural gas to LNG in three sections, which includes three temperature intervals of $36\text{ }^\circ\text{C} \sim -53\text{ }^\circ\text{C}$, $-53\text{ }^\circ\text{C} \sim -120\text{ }^\circ\text{C}$, $-120\text{ }^\circ\text{C} \sim -164\text{ }^\circ\text{C}$. Using three interval multi-streams LPFHE, heat transfer process from high to low was fulfilled in three intervals, and heat exchanger structure and the cryogenic heat transfer process were studied and developed.

The mixed refrigerant of C_4H_{10} -I- C_4H_{10} , which is pre-cooled from 36 °C and 0.9 MPa to -53 °C and 0.6 MPa, then throttled to -52.85 °C and 0.3 MPa, provides cold capacity for the first interval. C_3H_8 , which is pre-cooled from 36 °C and 2.18 MPa to -53 °C and 1.88 MPa, then throttled to -52.29 °C and 0.3 MPa, also provides cold capacity for the first interval. The mixed refrigerant of N_2 - CH_4 - C_2H_4 , which is pre-cooled from 36 °C and 2.18 MPa to -53 °C and 1.88 MPa, then C_2H_4 is liquefied and separated, super-cooled to -120 °C and 1.58 MPa, then throttled to -119.4 °C and 0.3 MPa and provides cold capacity for the second interval. N_2 - CH_4 is pre-cooled in the second interval and the third interval and finally to -164 °C and 1.38 MPa, then throttled to 0.3 MPa, and the temperature of N_2 is -185 °C, CH_4 is -163.5 °C, they all provide cold capacity for the third interval. Natural gas is cooled from 36 °C and 6.1 MPa to -164 °C and 5.3 MPa and entirely liquefied and super-cooled after three interval refrigeration and finally stored in LNG tank.

Fundamental theory

The main LPFHE contains the three refrigeration processes, which is independent but organically combined together. It is also convenient for transport and on-site assembly. Using C_4H_{10} -I- C_4H_{10} and C_3H_8 refrigeration processes in the first interval can pre-cool the mixed refrigerant of N_2 - CH_4 - C_2H_4 and natural gas to -53 °C. Using C_2H_4 refrigeration process in the second interval can pre-cool the mixed refrigerant of N_2 - CH_4 and natural gas to -120 °C. Using N_2 - CH_4 refrigeration process in the third interval can pre-cool the mixed refrigerant of N_2 - CH_4 and natural gas to -164 °C. A five-stream LPFHE is adopted in the first interval, a four-stream LPFHE is adopted in the second interval and a three-stream LPFHE is adopted in the third interval. Using non-azeotropic mixed refrigerant of N_2 , CH_4 , C_2H_4 , C_3H_8 , C_4H_{10} and I- C_4H_{10} can generate enough cold capacity and different evaporation temperature from 26 °C to -185 °C in order to reduce the entropy increment in three intervals in LNG liquefaction process.

Conclusion

The scientific calculation method of the mixed refrigerants involves N_2 , CH_4 , C_2H_4 , C_3H_8 , C_4H_{10} , I- C_4H_{10} multi-phase, multi-stream flow and cryogenic heat transfer in LNG liquefaction process. The accurate calculation of a number of heat transfer films, heat transfer coefficient and variation regularity are still key problems for the design calculation of LPFHE and still need further research and development. Because of variation of the heat transfer coefficient with phase changed refrigeration and multi-stream heat exchange at any time, especially more than 12 streams of different fluids exchange heat with multi-phase flow in each bundle. When all of the plate bundles are combined together, the calculation method of heat transfer becomes the key scientific problem. If this problem can be solved scientifically, the overall design of the LPFHE should be more scientific and effective.

The scientific balance algorithm of LPFHE is still a key problem needed for further study. According to the traditional calculation of total heat transfer coefficient, the multiple iterative calculations are required in refrigeration process. In order to make the total heat exchange balancing to the number of channels, the design process of LPFHE involves many iterative computation methods for multi-stream, multi-phase and cryogenic fluid, and the calculation software is needed for heat exchange equilibrium, which provide theoretical and calculating method for LPFHE.

Acknowledgements

This project was financially supported by *The fundamental research funds of department of finance in Gansu province* (214137), *The Gansu Natural Science Foundation* (1208RJZA234), *The master tutor project of Gansu Province* (1104-01). Thanks for *National Key Lab. of Vacuum & Cryogenics Technology and Physics* in China.

References

- [1] Zhang Zhou-wei. A cryogenic plate-fin heat exchanger with five-stream in the first stage of LNG liquefaction process[P].China: 201510040244.7, 2012.05.
- [2] Zhang Zhou-wei. A cryogenic plate-fin heat exchanger with four-stream in second stage of LNG liquefaction process[P]. China:201510042630.X, 2012.08.
- [3] Zhang Zhou-wei. A cryogenic plate-fin heat exchanger with three-stream in third stage of LNG liquefaction process[P]. China:201510040244.7, 2012.08.
- [4] Zhang Zhou-wei. A main cryogenic plate-fin heat exchanger with multi-stream mixed-refrigerant in the LNG liquefaction process [P]: China,201510051091.6, 2012.08.
- [5] Wang Sun-han etc., Plate-fin heat exchanger[M].Beijing:Chemical Industry Press,1984.
- [6] Min Zhao, Yanzhong Li. An effective layer pattern optimization model for multi-stream plate-fin heat exchanger using genetic algorithm[J]. International Journal of Heat and Mass Transfer 60 (2013) 480-489.
- [7] Zhang Zhou-wei. A cryogenic spiral coil-wound heat exchanger with four stream in the first stage of LNG liquefaction process[P].China:201110379518.7, 2012.05.
- [8] Zhang Zhou-wei. A cryogenic spiral coil-wound heat exchanger with three stream in second stage of LNG liquefaction process[P]. China:201110376419.3, 2012.08.
- [9] Zhang Zhou-wei. A main cryogenic spiral coil-wound heat exchanger with multi-stream mixed-refrigerant in the LNG liquefaction process[P]: China, 201110381579.7, 2012.08.
- [10] Zhang Zhou-wei, Wang Ya-hong. coil-wound heat exchanger [M].Lanzhou:Lanzhou University Press, 2014.6.
- [11] Zhang Zhou-wei. The cryogenic spiral coil-wound heat exchanger for unshifted feed gas cooler, [P].China: 201210569754.X, 2013.04.
- [12] Zhang Zhou-wei. The cryogenic spiral coil-wound heat exchanger for shifted feed gas cooler [P].China: 201310000047.3, 2013.04.
- [13] Zhang Zhou-wei.The three-stream cryogenic spiral coil-wound heat exchanger for feed gas cooler [P].China: 201310034723.9, 2013.05.
- [14] Zhang Zhou-wei. The main multi-stream coil-wound heat exchanger for the heat recovery of cryogenic liquid nitrogen[P].China: 201310366573.1, 2013.08.
- [15] Zhang Zhou-wei. The third-stage spiral coil-wound heat exchanger for the heat recovery of cryogenic liquid nitrogen[P].China:201310358118.7, 2013.08.
- [16] Zhang Zhou-wei, Xue Jia-xing, Wang Ya-hong. Calculation and design method study of the coil-wound heat exchanger [J]. Advanced Materials Research, 2014, Vols. 1008-1009: 850-860.
- [17] Zhang Zhou-wei, Li Lian-bo, Li Jun. The design and caculation software for coil-wound heat exchanger [Z]. Chinese Copyright Protection Center, 201310358118.7, 2011.09.