

Design of Multi-Functional Alcohol Concentration Detecting System

Zhang Chong, Zhang Yue

School of Electrical and Information, Southwest Petroleum University, 610500, Chengdu, China

e-mail: zhizhizi@aliyun.com

Keywords: Alcohol Concentration Detect; Ultrasonic Wave Ranging; Printed Circuit Boards; AD Conversion; Simulation Test

Abstract. This paper is mainly design of alcohol concentration detector. Single chip microcomputer STC89C52 is employed to process data and control logic. Alcohol concentration sensor MQ-3 as its core detection device, which test the ethanol vapor concentration in the air. AD converter ADC0832 as auxiliary chips, which convert MQ-3 alcohol concentration sensor output analog voltage into corresponding digital voltage, and transmit its value into the core device. Ultrasonic wave sensor HC-SR04 can measure body distance, and adjust body weather within the 30cm safely distance. LCD1602 as display screen, which display alcohol concentration and detect distance. Test results proved that the system has higher precision and practicability, and is very effectively and economically.

Introduction

At present, most countries are using the breath alcohol concentration tester driving personnel on-site testing to ensure the safety of the driver's life and property. Alcohol concentration sensor can detect the driver's breath alcohol density, breath alcohol steam combustion chemical reaction happens within the sensor voltage, measure the voltage value can get the corresponding alcohol density, more than warning value, represents the driver and the drunk driving, system alarm. In this system also join the ultrasonic ranging, open in the driver's proximity sensor detection, in order to prevent the error of the disturbance of environment. In this paper a new optimal design of soccer robot control system which is based on mechanical analyses and calculations on the pressure and transmutation states of chip kick mechanics, this new control system with high precision for speed control and high dynamic quality.

The alcohol concentration testing device contains four types, there are cell fuel type, semi-conductor type, infrared type, gas chromatographic analysis and color type. Because of price, cell fuel type and semiconductor type are mainly popular on the market currently. Cell fuel type is the new energy in environmental research, can put the chemical energy of gas directly into electricity without pollution. Alcohol sensor just a small branch of it, in the combustion chamber filled with special chemical catalyst, blowing alcohol steam and combustion generating voltage, measure the output voltage can obtain the corresponding alcohol value. Compared with the semiconductor type, the cell fuel type of respiratory alcohol concentration tester has better stability, accuracy and anti-interference. However, due to the structure is relatively reasonable, and the production costs are higher and manufacturing is difficulty, only a few countries can produce.

System Structure

The system with simple design, mainly composed of AT89C52 microcontroller circuit, MQ-3 alcohol concentration sensor, ultrasonic ranging module, amplifying circuit, ADC0832, buzzer, LCD1602 display, power module, and LED indicator. The ultrasonic ranging can detect human within a given range and by MQ-3 alcohol concentration sensor to detect the concentration of alcohol to a voltage signal output through the DAC0832 input to the MCU with the given value, and the realization of the LCD1602 display, the concentration of more than a given value will alarm. MQ-3 alcohol concentration sensor output linear signal voltage can be directly through the size of

the voltage signal in the MCU programming to the concentration corresponding to the value. In order to prevent the interference signal, two MQ-3 alcohol concentration sensor is adopted to take the average value, and join the ultrasonic ranging module to prevent in the people did not close on space of detection concentration cause interference. The system structure block diagram is shown as Fig.1.

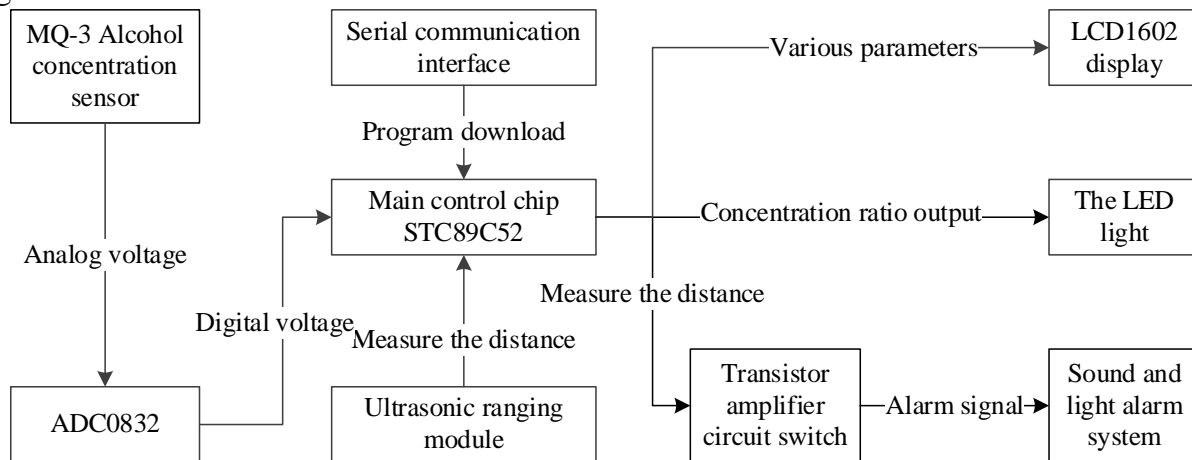

Fig.1 System Structure Block Diagram

System Functions

The device have the main function as follows. (1)Measure the alcohol concentration value. (2) Modify the alcohol concentration set value. (3)Brownout protection. (4)Setting value alarm.(5) Display set parameters. (6)Measure body safely distance. (7)Regulate sensor zero drift. (8)Alcohol concentration display lights.

Hardware Design

A. MQ-3 Alcohol Concentration Sensor

According to the principle of electrochemistry, the use of gas in the electrolytic cell under test working electrode potential on the electrochemical oxidation process, the gas produced by electrochemical reaction under test current is proportional to its concentration and Faraday's law, by measuring the size of the current can determine the concentration of gas under test. In practical application, is the size of the test the voltage, and converted to the corresponding digital signal input system. The digital signal corresponds to the size of the corresponding alcohol density, so that you can detect alcohol concentration.

And select MQ-3 alcohol concentration sensor because it have the advantages of high sensitivity to alcohol gas, with good reproducibility and long-term stability, strong anti-interference, on alcohol gas has good selectivity and the device need power consumption is very small, and cheap.

B. ADC0832 Converter

ADC0832 is a 8 bit resolution A/D conversion chip, the highest resolution can reach 256, can meet the general analog conversion requirements. Reuse of its internal power input and reference voltage, making the chip analog voltage input 0~5V. Chip switching time is only 32 μ s, possess double data output can be as check data, in order to reduce the error data, the conversion speed and stable performance. Independent of the chip enable input, the device hanging and processor control becomes more convenient. Data input through the DI can easily achieve the channel function selection.

C. Ultrasonic Ranging Module

There are many types of ultrasonic ranging module, the more commonly used have HC-SR04

ultrasonic sensor is 232 interface by default and can be adjusted to interface with TTL, URM05 high power ultrasonic sensor test distance can to 10 meters, the testing distance of a the objects, in addition to the more commonly used foreign several SRF series ultrasonic module, the accuracy of the ultrasonic module can to 1 cm.

D. LCD1602

Character liquid crystal on the market mostly based on HD44780 LCD chip and control principle is exactly the same, so HD44780 write control program based on can is convenient in application in the market most of the characters in the crystal. Character LCD module internal memory (cgrom) has already been stored 160 different character dot matrix graphics, these characters are: to write Arabic numerals, letters of the alphabet size, commonly used symbols and Japanese kana and, every character has a fixed code, such as uppercase letters "a" of the code is 01000001B (41h) and show that when the module to address 41h character dot matrix graphic display, we can see the letter "a". In the SCM program can also use character constants or variables, such as 'A'. Because cgrom storage character code with our PC character code is basically the same, so we to DDRAM C51 written character code can even directly by P1= 'a' in this way. PC 'A' was first converted to 41H code at compile time.

Software Design

The system software is mainly contain six parts. There are key board program; alarm program; power down protection; acoustic distance; distance measurement and judgment and LED display. The system software chart is shown as Fig.2.

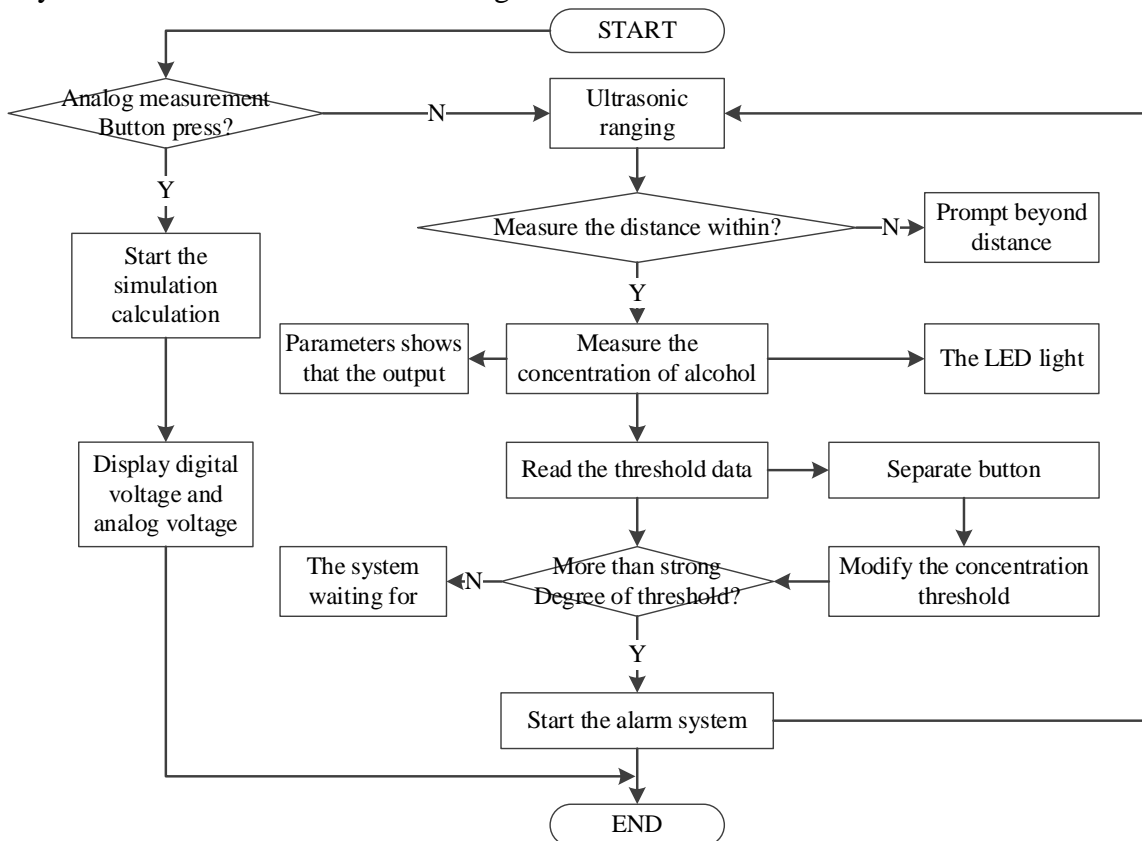

Fig.2 Software Chart

Simulation Test

In order to simulate the practical circuit run, software of Proteus is employed, which compiles program in c language into hex file, and can import microcontroller. Simulation working is based on the voltage produced by the variable resistor instead of the sensor produces voltage, and can finish a simulation test. Simulation circuit diagram is shown as Fig.3.

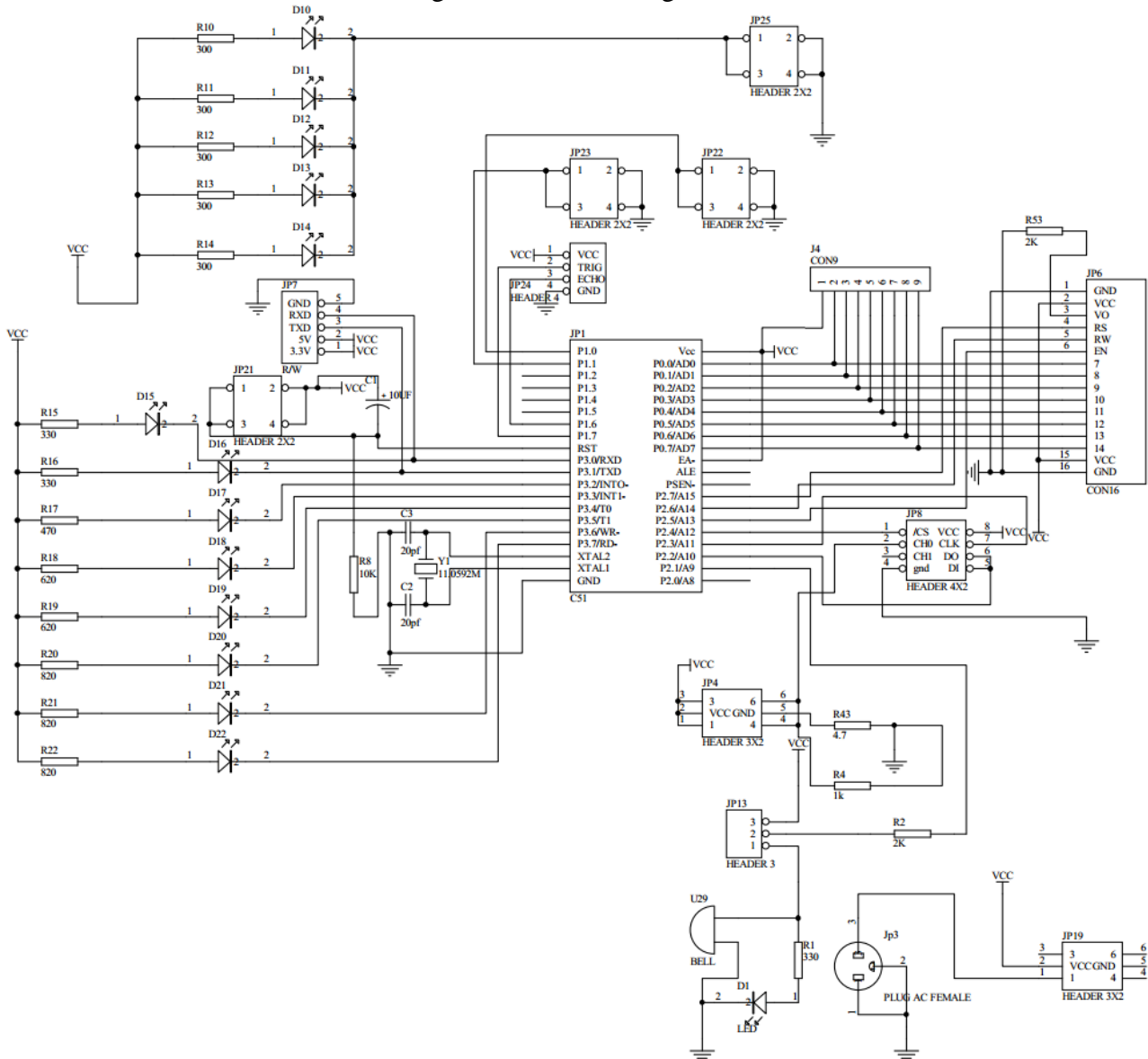

Fig.3 Simulation Circuit Diagram

Printed Circuit Board

Software of Protel 99 SE is employed to finish PCB, according to draw good electrical connection in the circuit connection diagram. Firstly, the Protel Schematic is redrawn in Sch-File, the electrical connection Protel Schematic Diagram is the same as Fig.3.

PCB made follows the 6 steps.

1. Power line wires need bold treatment, to reduce interference and resistance.
2. Digital circuits and analog circuits were dealt with to avoid interference.
3. Signal wire cloth in electric (ground) layer.
4. Treatment of a large area of connected leg conductor. In the large area of the ground (electric) in common components of the legs are connected, the connection legs need to be considered,

electrical properties, components of the leg pads and the copper surface full connected as well.

5. Dense grid, pathway, although increased, but the step is too small, field maps of large amounts of data, so it is necessary to control appropriate network density.

6. Connect the components.

In order to keep the size of the layout as compact as possible, to reduce the size of the layout and save costs. After the arrangement we can auto route to generate PCB board, which is shown as Fig.4.

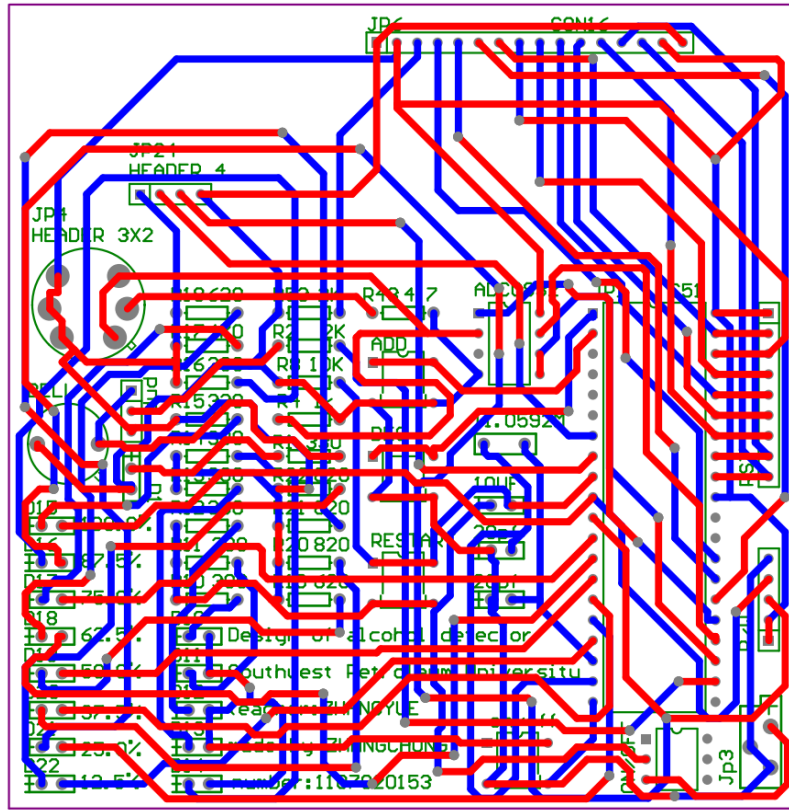

Fig.4 PCB Circuit Diagram

Test results

People outside the 30 cm will not open the alcohol concentration detection, display chroma value is stere of 0, DIS OUT said too far away. Within the range can be measured, and in proportion to the measured value and the threshold is given, every bright a led for each 12.5%.

Within the range can be measured, more than the threshold will call the police, buzzer sounds in order to improve drivers belong to drunk driving. The test results are shown as Fig.5.

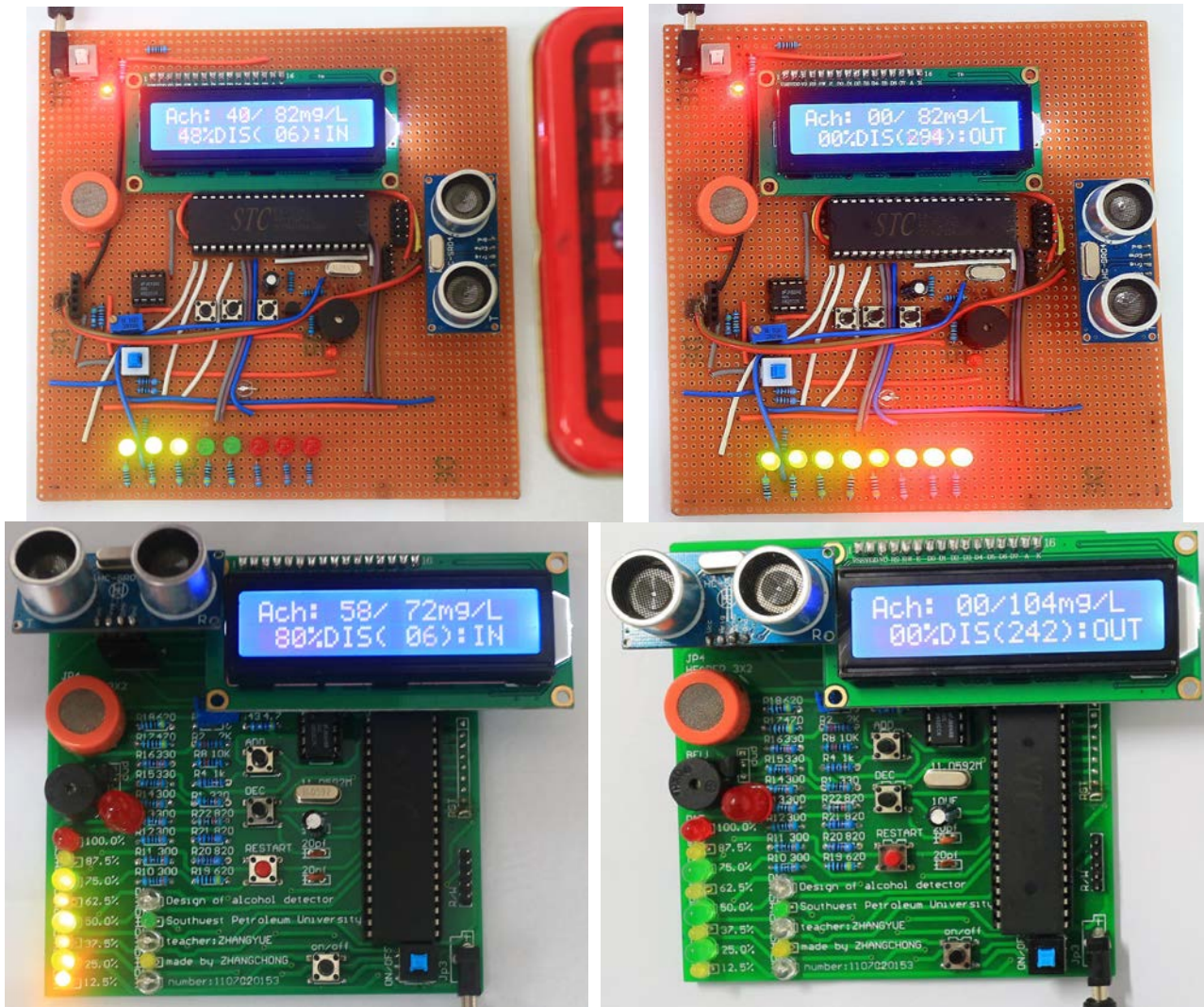

Fig. 5 Test results

Conclusion

Single chip microcomputer ATC89C52, alcohol concentration sensor MQ-3, Ultrasonic wave sensor HC-SR04, AD convertor ADC0832 are mainly components in this design. And auxiliary components are display screen LCD1602, LED lights, serial communication module and buttons. This paper are hardware and software design, which work together to finish the multi-functions. Hardware circuit and structure design reasonably, while software design is used modular ideas. The innovation of the device is added ultrasonic wave sensor, which measure the distance of body to insure weather within the reasonable ranges. Through the test to get the final performance parameters of the detecting system. Test results show that the system has higher accuracy and stability, the new design basic requirements, and achieved good ideal control effect.

References

- [1] Fan Lina. Single chip microcomputer interface and control technology [M]. Shenyang: liaoning university press. 1996, 110-135.
- [2] Hu Hancui, single-chip microcomputer principle and interface technology [M]. Beijing: tsinghua university press. 1996, 281-288.
- [3] Yen-Liang Yeh, Yen-Pin Lin. High-precision measurement system based on laser interferometer for determining alcohol concentration of liquid solution [J]. Optics Communication, 2008, 744-749.

- [4] Ravi Kumar, R. R. Das, V.N. Mishra, R. Dwivedi. A Neuro-Fuzzy Classifier-Cum-Quantifier for Analysis of Alcohols and Alcoholic Beverages Using Responses of Thick-Film Tin Oxide Gas Sensor Array [J]. IEEE Sensors Journal, 2010, Vol.10 (9):1461-1468.
- [5] Yuan Jie. Design of the alcohol concentration detector based on 51 single-chip [J]. Electronic Design Engineering, 2013, Vol.21 (18):173-175.
- [6] Zhou Hongwu. Design of alcohol concentration detector based on single chip computer [J]. Manufacturing Automation, 2012, Vol.34 (1):147-149.
- [7] Lan Yu, Bai Jie. Design of alcohol concentration tester based on AT89C51 [J]. Information Technology, 2013, (10):74-76.
- [8] Li Jianrong, Xue Yaping, Qian Song. Design of Alcohol Concentration Detector Using MCU [J]. Journal of Nantong Textile Vocational Technology College, 2013, Vol.13 (4):20-23.