

Design of UPS Inverter Control System Based on DSP

Qian Yang^{1, a}, Mingming Guo^{2, b} and Jianhua Dou^{1, c}

¹School of Computer and Information, Hefei University of Technology, Hefei 230009, China

²Teaching Affairs Office, Hefei University of Technology, Hefei 230009, China

^a774576934@qq.com, ^bguomingming_ai@sina.com, ^cjsjtxdjh@hfut.edu.cn

Keywords: Inverter; double closed-loop control; repetitive control; RMS control.

Abstract. To obtain high-quality output voltage, a multi-loop control for UPS inverter is proposed. On the basis of double closed-loop control, repetitive control is introduced to improve total harmonic distortion (THD) of the output voltage. Also, RMS control is introduced to increase steady-state accuracy of the output voltage. Then, the choice of various control programs is discussed and the design of related parameters is analyzed. Experimental results verify the effectiveness of the control method in a 10kVA UPS inverter prototype.

1. Introduction

There are two different types among inverter systems, voltage output type and current output type. The inverter in the Uninterruptible Power Supply (UPS) system is a typical voltage type inverter. Previous methods [1], including PID, double closed-loop, state response, repetitive control, hardly achieve a high dynamic response and a high-accuracy stable wave. Therefore, the inverter control strategy tends to compound control. Based on the double closed-loop control of PID adjuster, compound control obtains higher dynamic response and stable performance and, to a certain extent, represses disturbances, which makes it of general uses in industry. However, because of adding dead zone delay and the effect of nonlinear load on output filter, the output voltage distorts more. It is compensated by the introduction of repetitive control in control systems [2, 3], system dynamic responses slowly with single repetitive control nevertheless. UPS inverters have varieties of kinds of loads and the output voltage value of the inverter changes with the load, thus the steady-state accuracy of the output voltage is affected negatively[4].

Dynamic and static characteristics are both considered in this article and a compound control method is proposed based on double closed-loop, repetitive control and RMS control. The experiment verifies it is viable and controls well.

2. The control model of inverter

The topology structure of diode-clamped three-level inverter as shown in Fig.1, inverter is supplied by DC Bus+ (BUS +) voltage v_{BUS+} and DC BUS- (BUS-) voltage v_{BUS-} which are outputted by rectifier. C1 and C2 are two same dividing capacitor, in the inverter bridge, the high and low bridge arm have two IGBT power tube, which are respectively Q1, Q2, Q3 and Q4. L and C are respectively output filter inductance and capacitance, and r is equivalent resistance of L, R for arbitrary load. i_L , i_C , i_o are respectively current inductor, capacitor and load current, v_o is the output voltage. System parameters are as in Table 1.

The inductance current i_L and capacitance voltage v_o are chosen as the state variables, the load current i_o as a disturbance input of inverter, through the state-space averaging method, control model of the inverter in the frequency domain is shown in Fig.2. Among them, K_{pwm} is transfer function from modulation signal inputting to the output voltage u_{ab} in the inverter bridge.

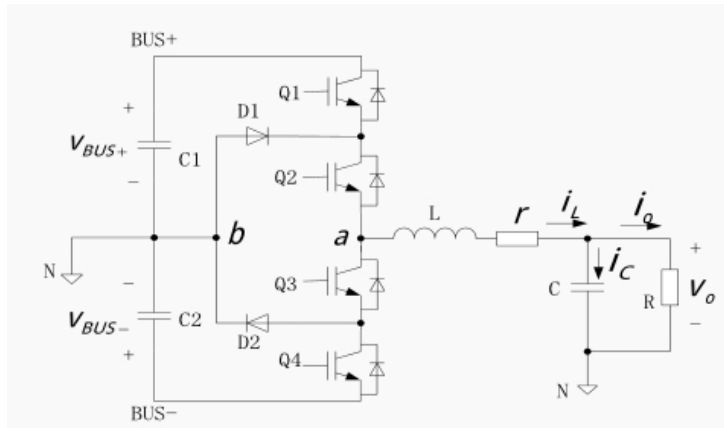

Fig.1 The topology structure of inverter

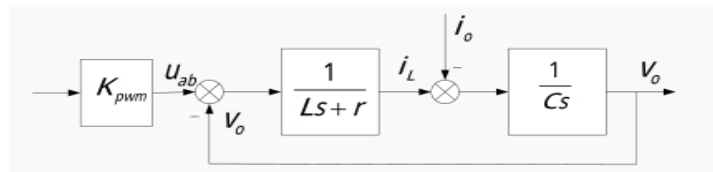

Fig.2 The control model of inverter

3. The Control System Design of Inverter

The structure diagram of composite control scheme is shown in Fig.3. In the Fig.3, v_{rms} is RMS reference of output voltage?

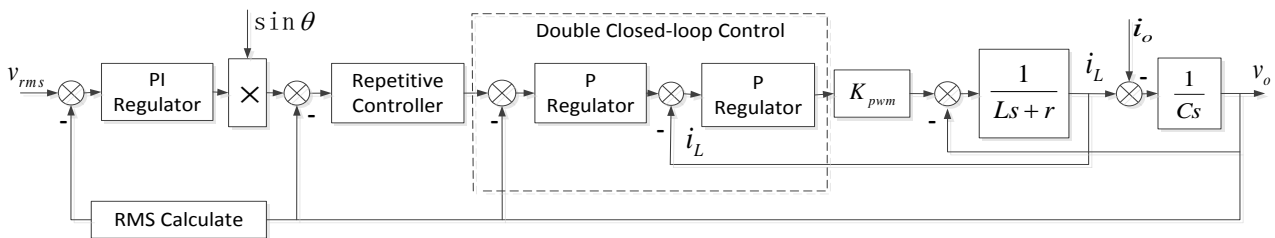

Fig.3 The structure diagram of composite control scheme

Double Closed-loop Control Design. In the double closed-loop control, the feedback quantity of voltage loop select output voltage, and feedback quantity of inner loop of current select inductance current, so that the inverter can be made current limiting protection [5]. In order to simplify the design, the output voltage are made feedback decoupling, meanwhile, K_{pwm} are compensated, the load current are made feed-forward control [6], in order to suppress the distortion load changes caused by output voltage, improve the response speed and load disturbance resistance of system. After the above decoupling and compensating, inner loop of current and voltage loop adopt proportional control, which can achieve good effect, the parameters of proportional regulator are respectively K_V , K_C , simplified double closed-loop control system diagram as shown in Fig.4.

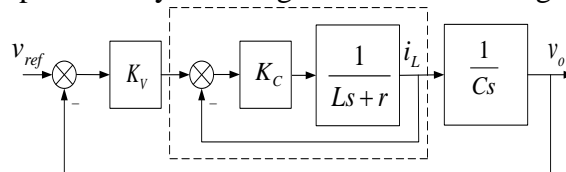

Fig.4 Simplified double closed-loop control system diagram

In Fig.4, the inner of dotted box is current loop, its controlled object is inertial link, so when using proportional control, system is always stable, but before the compensation, the crossing frequency of current inner loop is too low, the low frequency gain is small, it cannot meet the requirement of the system performance, so add the compensating network K_c to improve, after the compensation crossing frequency of current inner loop is 1.5 kHz. Considering the system has high dynamic response, the crossing frequency of voltage loop is set to 1 kHz, after compensation, open-loop transfer function of current inner loop and voltage outer loop are respectively:

$$G_c(s) = \frac{K_c}{Ls + r} \quad (1)$$

$$G_v(s) = K_v \cdot \frac{G_c(s)}{1 + G_c(s)} \cdot \frac{1}{Cs} \quad (2)$$

Bring the parameters in Table 1 to formula (1) and formula (2), we can obtain $K_c = 4.74$, $K_v = 0.243$. After verifying, the phase margin of voltage loop is 59° , which meets the requirement of stability.

Repetitive Controller Design. The periodic disturbance caused by the dead zone delays [7] and load affects the output voltage waveform, repetitive control can be used for correcting to improve the THD of output voltage [8]. Repetitive controller is embedded in control system diagram of UPS inverter as shown in Fig.5, $Q(z)z^{-N}$ is repeated signal generator, z^{-N} is the life cycle delay, $C(z)$ is the compensator, and $C(z) = K_r \cdot z^k \cdot S(z)$, $Q(z)$ can be a low-pass filter or constant slightly less than 1. N is sampling frequency of controller in fundamental cycle. For the compensator $C(z)$, $K_r = 1$ are assumed, after the completion, the design then are adjusted. $S(z)$ is usually marked a second-order low-pass filter to realize the high frequency attenuation [9]. Phase compensation z^k counter the phase lag of tracking signal, make $z^k S(z)P(z)$ in the low frequency approximate zero phase. Considering the repetitive control needs accumulation of cycle error, the dynamic response is slow, a feed-forward channel is introduced in the practical engineering in order to improve dynamic response. $P(z)$ is the controlled object of inverter after the double closed-loop control.

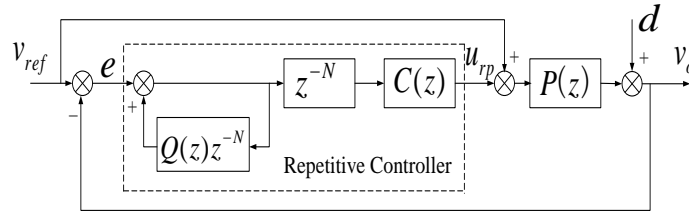

Fig.5 Repetitive control system diagram

After add double closed-loop, continuous domain model of inverter are as follows:

$$P(s) = \frac{K_v K_c}{LCs^2 + (r + K_c)Cs + K_v K_c} \quad (3)$$

For formula (3), after bring the related parameters and discrete:

$$P(z) = \frac{0.08584z + 0.07152}{z^2 - 1.423z + 0.5799} \quad (4)$$

General second-level low-pass filter is designed as follows:

$$S(s) = \frac{w_n^2}{s^2 + 2\xi w_n s + w_n^2} \quad (5)$$

In the formula, w_n is the natural frequency, ξ is the damping ratio. $\xi = 0.7$, $w_n = 3200\pi$.

The parameter is into formula (5), after discretization:

$$S(z) = \frac{0.1063z + 0.08317}{z^2 - 1.292z + 0.481} \quad (6)$$

When advanced link is z^7 , phase compensation effect is good, so $k = 7$, when $Q(z)$ is 0.95. In the design, $Q(z)$ is 0.95, K_r is 1, after verifying, the test system is stable.

RMS Loop Design. When the inverter load changes bigger, the output will appear serious reducing pressure phenomenon, it can't meet the requirements of voltage RMS steady-state accuracy. So RMS loop control is introduced, the amplitude of the output voltage is adjusted, thus eliminating static error of RMS. From the viewpoint of control, transfer function of RMS loop controlled object is the corresponding gain of system closed-loop transfer function through the double loop control and repetitive control in 50 Hz frequency. In this design, this gain can be approximately equivalent to 1, so the simplified control diagram of RMS outer loop as shown in Fig.6, v_{rms} is reference instruction RMS of the output voltage, which is 220 v. v_{orms} is the RMS of output voltage.



Fig.6 RMS loop control simplified diagram

RMS loop adopts proportional integral control, the transfer function of PI regulator is $H_w(s)$, then:

$$H_w(s) = K_p + \frac{K_I}{s} \quad (7)$$

The parameters of formula (7) are designed, zero point are 100Hz, after compensation the cross-over frequency of RMS outer loop is 10Hz, therefore, the equations can be obtained:

$$\begin{cases} \frac{K_I}{K_p} = 200\pi \\ |H_w(s)|_{s=j2\pi \times 10} = 1 \end{cases} \quad (8)$$

Obtain $K_p = 0.1$, $K_I = 62.8$.

4. Experimental Results

In order to verify the correctness and effectiveness of the control algorithm, the diode-clamped three-level inverter prototype are set up. Power device is IGBT module (10-FZ06NIA050SA), control chip is TMS320F28335 DSP of TI company, other system parameters as shown in Table 1.

Table 1 System parameters of the simulation and experiment

Parameters	Numerical value
Switches and sampling frequency	19.2kHz
BUS voltage	360V
Dc side capacitor C1=C2	470uF
Filtering inductance	500uH
Filtering inductance equivalent resistance	0.5 Ω
Filter capacitor	30uF
Reference sinusoidal frequency	50Hz
The output voltage RMS	220V

Fig.7 (a) and (b) respectively are a the output voltage waveform of inverter with linear load and nonlinear load, the output voltage THD are respectively 0.91%, 2.6%.

Fig. 8 (a) and (b) are the dynamic response experiment waveform of inverter output voltage, when sharp reduction linear load and nonlinear load, the recovery time of output voltage can be respectively

controlled within 10 ms and four fundamental wave cycle, it is visible that this control scheme can obtain fast dynamic response. After measurement, when load changes, the steady precision of output voltage RMS is greater than 99%.

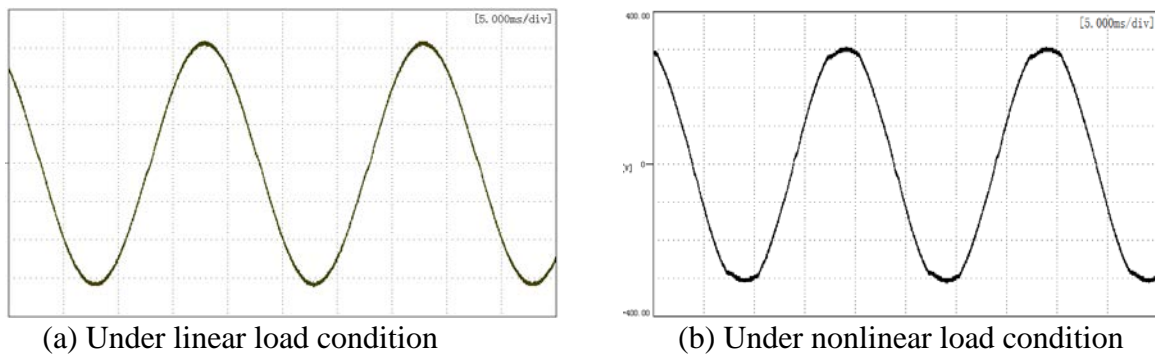

Fig.7 Output voltage THD experiment

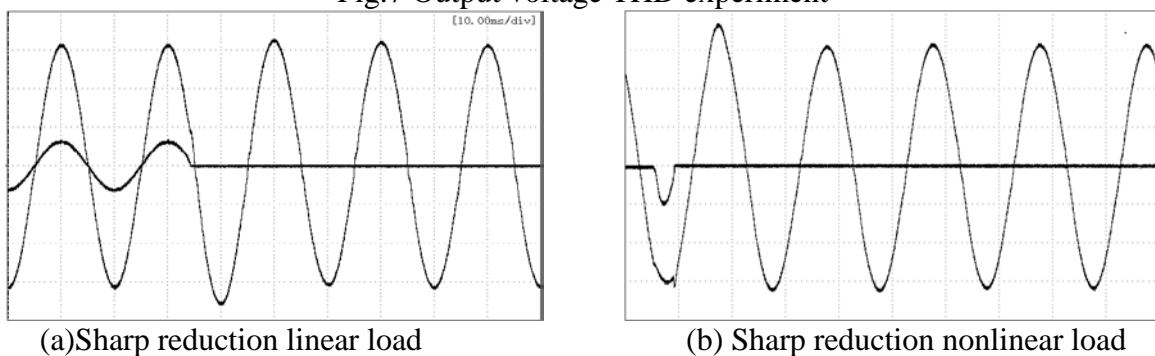

Fig.8 Dynamic response experiment

5. Conclusion

According to the issues of diode-clamped three-level inverter appeared in UPS application, the control scheme of inner double closed-loop control, middle repetitive control and outer RMS control is introduced. Experimental results show that the proposed scheme can obtain a good compensation effect, and the steady-state accuracy and THD of output voltage can meet the requirements. Simultaneously, the inverter system can also achieve fast dynamic response.

References

- [1] J. Gao. Digital Control Technology for UPS Inverters, *Electro-technical Journal*, 12:6-9, 2001
- [2] K.L. Zhou, D.W. Wang. Digital Repetitive Learning Controller for Three-phase CVCF PWM Inverter. *IEEE Transactions on Industrial Electronics*, 4: 820-830, 2001.
- [3] K. Zhang, Y. Kang. Direct Repetitive Control of SPWM Inverter for UPS Purpose [J]. *IEEE Transactions on Power Electronics*, 3:784-792, 2003.
- [4] N. Zhang, J.J Shi. Design of the 400Hz Three-loop Three-phase Inverter, *Mechanical & Electrical Engineering Magazine*, 6: 63-66, 2008.
- [5] P.C. Loh. A Comparative Analysis of Multi-loop Voltage Regulation Strategies for Single and Three-phase UPS Systems [J]. *IEEE Transactions on Power Electronics*, 5:1176-1185, 2003.
- [6] S.L. Jung. DSP-based Multiple-loop Control Strategy for Single-phase Inverter Used in AC Power Sources, *IEEE PESC '97 Record.,28th Annual IEEE*, St. Louis, MO, pp.706-712, 1997.
- [7] S.X. Duan, Z.H. Sun, A Compensation Strategy for Dead-time Effect of SPWM Inverters Based on Repetitive Control, *Transactions of China Electro-technical Society*,2:52-57,2004.
- [8] M.C. Tsai, W.S. Yao. Design of a Plug-in Type Repetitive Controller for Periodic Inputs, *IEEE Transactions on Control Systems Technology*, 4:547-555, 2002.

- [9] G.F. Teng, G.C. Xiao. A Single-loop Current Control Method for LCL-filtered Grid-connected inverter Based on the Repetitive Controller, Proceedings of the CSEE, 24:13-21,2013.