

A Wireless Mouse Based on Head Control

Teng-fei SONG, Qing-bang HAN, Fu-lin LI, Xue-ping JIANG, Jing JIA, Chang-ping ZHU
College of IOT Engineering Hohai University
Changzhou, China

Abstract: A wireless mouse based on head control is proposed to control the moving direction of computer cursor by sensing the titling direction of user's head. This kind of operational approach make the non-arm disabled using computers realized. The direction induction module is used to sense the tilting of four directions. With the MCU timer, automatic execution of left-click and double-click is available. The MCU of receiver controls the moving and the time to click of the computer cursor. Data transmission of short distance between mouse and receiver is available by using NRF wireless technology, which can make the non-arm disabled control a computer cursor easily. The system provides the disabled a more comfortable way to control the computer. The design has much potential to be applied to lots of occasions.

Keywords: Head Control; Direction Induction; Click Automatically

I. INTRODUCTION

The mouse[1] is essential when we use computer. With the mouse we can enjoy fast and convenient Internet, which brings much convenience to us. The non-arm disabled cannot use mouse conveniently like normal people, which means that surfing on the internet is a difficult thing for them. Surfing on the Internet is a very important way for exchanging information, which is more important for disabled people. There are some devices that can help the disabled to use mouse by eyes[2], which are based on image processing. But the common problem is that the disabled will be easier to feel tired if they use their eyes for a long time. So in order to solve the problem of surfing on the internet for non-arm disabled, we propose the use of wireless mouse based on head control, which is comfortable and cheap.

II. METHOD OF CONTROL

A. Direction control

The equipment worn on the head, the user can control the computer cursor by tilting the head. The computer cursor moves to the left when users' head tilt to a certain angle toward the left (the critical value of the tilt angle can be adjusted according to the needs of users). And the same with computer cursor moving to the right or moving upward and downward.

B. Method of click

When user makes the computer cursor stop for about 2.5 seconds, the mouse executes the function of left click

automatically. The mouse executes the function of double-click automatically with two more seconds for stopping. The disabled needn't use any button to click.

III. DESIGN OF THE SYSTEM

Overall design of the system is described in Fig.1.

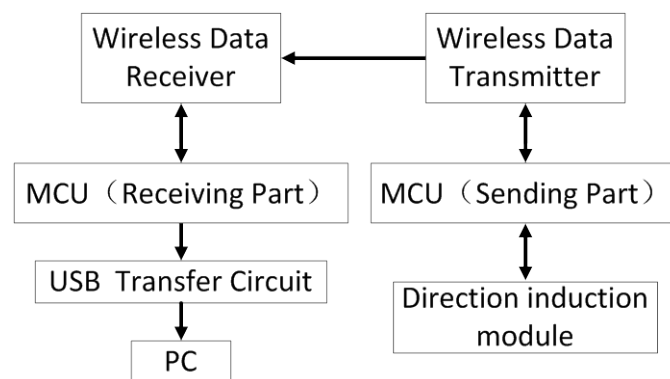

Fig. 1 Overall Design

First, the direction induction module senses the tilting direction of user's head. Direction induction module will produce four different signal output when the head move left, right, upward and downward respectively. The MCU will transmit the direction signal through the wireless data transmission module when direction tilting is detected. After the signal is received by the wireless receiving module, the received signal will be transferred to the MCU of the receiver. And the MCU will process the signal data, judging the stopping time of the computer cursor, and then execute the corresponding functions. MCU of receiving part sends the data to PC by USB transfer circuit. The working voltage of system is 5V.

A. Design of the direction induction module

The direction induction module is an essential module in wireless mouse based on head control. The hardware diagram of the direction induction module in one direction is described in Fig. 2. This part uses the SCA60C-N1000060 chip produced by VTI Technologies Corporation[3]. Two chips are vertically arranged and tilting of four different directions can be sensed. Analog signal is the output of the system. Hence, analog signals are converted to digital signals according to the standard value of the voltage comparer, which brings much convenience to the MCU processing. The standard value of the voltage can be made by there voltage divider resistances. If the tilting of one direction is sensed, MCU will get a low voltage.

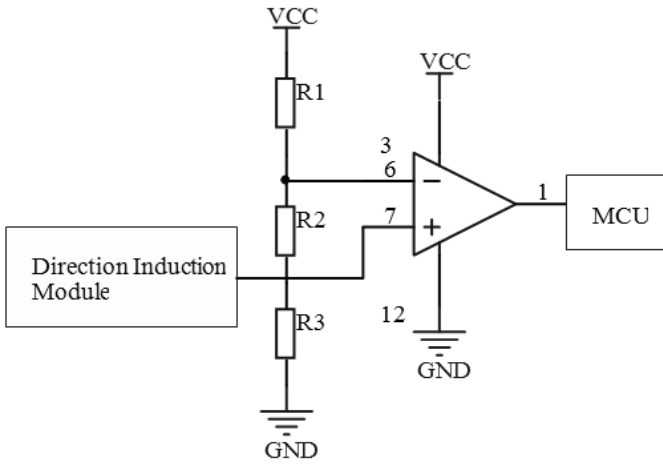

Fig.2 Hardware Diagram of the Direction Induction Module

B. Design of the wireless transmission and receiving module

The module uses the NRF2401 chip produced by Nordic for short distance wireless transmission. With NRF2401[4], the data can be transmitted or received for short distance. It works on the frequency band 2.4GHz~2.5GHz in ISM. Wireless control is realized by transmitting the signal from MCU of the transmitter to MCU of the receiver. The size of the wireless transmission and receiving module is small, which is suitable for this module.

C. Program design in MCU of the receiver

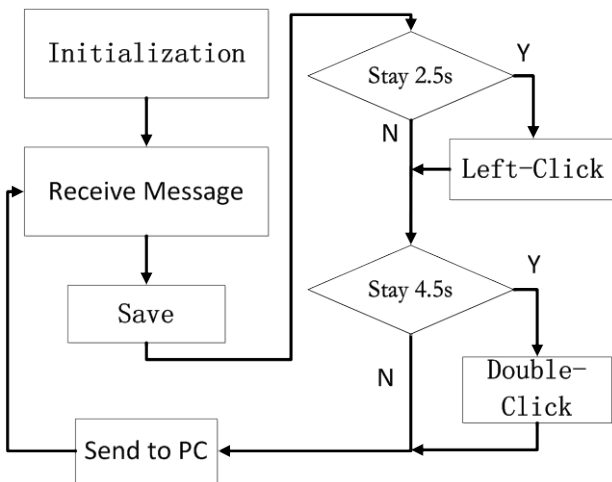

Fig.3 Program Flow Diagram of MCU

The MCU of the receiver is an important part of the system and the program make the system work according to our design. The data can be sent to PC with the MCU of the receiver communicating with the computer. MCU of the receiver is not only responsible for communication with the computer, but also for the control to make the mouse do the operation of left-click. Program design diagram is shown in Fig.3. First do the initialization, and then enter the loop for wireless data reception. Then the data will be stored and judge if the computer cursor has been motionless for 2.5 seconds. Then automatic left-click will be done. If not, then judge if the

cursor has been motionless for 4.5 seconds. If, double-click will be done. If not, then the MCU will transmit control information to computer and wait for receiving data.

D. Design of USB transfer circuit

The design of USB transfer circuit uses PDIUSBD12 chip produced by Philips Corporation. PDIUSBD12 is a good USB device, which is usually used in the system based on micro controller and is used to communicate with micro controller through high-speed general parallel interface. And it complies with USB1.1 protocol specification. The kind of components of the USB interface makes it possible for the designer to choose a most suitable micro controller in a variety of different types of micro controller, whose flexibility reduces the time risk of research and costs by using the existing structure and reducing the investment on the firmware. Hence, it is possible to achieve the most economical solution of USB with the most efficient method of peripherals. MCU in the receiver can easily establish communication with computer to achieve the effect of controlling the computer cursor.

IV. EXPERIMENT AND DISCUSSION

A. Experiment of system



Fig.4 Physical model of the system

We put the mouse on the headset to do the test for the mouse. Some key information of the mouse is shown in List 1. When user's head tilt in four different directions, the cursor moved in for direction respectively. When user's head was motionless for 2.5 seconds and 4.5 seconds, left-click and double-click was done respectively. The physical model of the mouse is shown in Fig.4.

B. Analysis of the system

This kind of device controls the mouse by tilting head. Computer cursor will move toward a direction by a fixed speed. Compared to the device that the computer cursor move follow the the track that the head moves, it will make the disabled feel uncomfortable even use the mouse for a long time. The size of the system is 6cm×4cm×1.5cm, and the

working voltage is 5V. Main parameters of the mouse are described on TABLE1.

TABLE I. MAIN PARAMETERS OF SYSTEM

<i>Working voltage</i>	<i>size</i>	<i>Working temperature</i>
5V	6cm×4cm ×1.5cm	253K~385K

V. CONCLUSION

The wireless mouse based on head control realized the function of controlling the computer cursor by sensing the tilting direction of user's head. And we innovatively use the timing function to make the mouse do certain operation according to our needs, which satisfy the needs of the non-arm disabled. The design makes it possible for them to control the home appliances by using the technology of things of internet[5]. It proves that our design have a bright future of being applied to many occasions.

ACKNOWLEDGMENT

This work were supported by National Natural Science Foundation of China (No.11274091, 11274092) and the Funds for the Central Universities of Hohai University (Grant No. 2011B11014, 2015B04714)

REFERENCES

- [1] Hu, A.P.; Kwan, I.L.W.; Tan, C.; Li, Y., "A Wireless Battery-less Computer Mouse with Super Capacitor Energy Buffer," *Industrial Electronics and Applications, 2007. ICIEA 2007. 2nd IEEE Conference on*, vol., no., pp.2024,2029, 23-25 May 2007 doi: 10.1109/ICIEA.2007.4318765
- [2] Kim Eun Yi, Kang Sin Kuk, Eye Mouse: Mouse Implementation Using Eye Tracking [A]. IEEE International Conference on Consumer Electronics [C], 2005, 1: 207-208
- [3] SCA60C Product Specification [EB/OL] . www. 51sen - sor. com, 2003.
- [4] Tianxing Hou, Fengxin Wang, Wireless Data Transmission System Based on NRF2401[J]. *Chinese Agricultural Science Bulletin* 2009,07:258-263.
- [5] CASAGRS.RFID and the Inclusive Model for the Internet of Things[OL].<http://www.rfidglobal.eu/userfiles/docu-ments/FinalReports.pdf>,2010-02-01.