

Study on New joint Technique for ABS Thermoplastic Materials: Electric Resistance Hot-driven Riveting

Changqing Zhang^{1*}, Shengtian Bai¹, Yongfeng Shi², Shaolong Jin¹, Lidong Yang¹,

¹State Key Laboratory of Advanced Processing and Recycling of Nonferrous Metals, Lanzhou Univ. of Tech. Lanzhou 730050, China

²Lanzhou Netzsch Pump Industry Co, Ltd. Lanzhou 730050, China

¹zhangcq@lut.cn

Keywords: Riveting; ABS; Duty Cycle ; Thermoplastic

Abstract. Electric Resistance Hot-driven Riveting is a new alternative spot joining process developed for polymer multi-materials structures. In the technique, a cylindrical metallic rivet is used to join one or more thermoplastic components by means of forming rivet heads on both sides of connected joint through pressure and resistance heat, which has the advantages of both mechanical rivet and resistance spot welding. In this paper, the experiments for ABS thermoplastic materials were carried out by Electric Resistance Hot-driven Riveting process, which can be clearly distinguished three stages: the cold riveting deformation, hot riveting molding and steady deformation, by acquiring and analyzing the change in the base material temperature, electrical current, voltage, electrode displacement in the riveting process. Also, mechanical property and failure mode of the joint at different duty cycles have been carried out and analyzed, shown the maximum strength of which can be up to 79% of that of base material, and indicated that Electric Resistance Hot-driven Riveting of ABS thermoplastic materials could obtain the joint of significant mechanical property, and verified that Electric Resistance Hot-driven Riveting would become a promising thermoplastic material connection method.

Introduction

Material of plastic is widely used in the automotive, household appliance and electronic technology industries, particularly in the automotive industry, along with the automotive lightweight development demand and the automotive plastic technology extensive application ^[1], the reliable plastic connection technique will attract more and more attentions of the researchers and manufacturers. At present, the main plastic connection techniques in the industrial application includes welding, riveting and bond, but some Rmethods are characterized by complex process, high cost and narrow application; therefore, people are constantly seeking for new material connection techniques. Electric Resistance Hot-driven Riveting is one of the few joining methods that can be used to connect both metallic materials and non-metallic materials ^[2,3], See Figure 1 for the schematic of riveting process. Metal rivets are implanted at the two overlap joints, and powered and pressurized by pushing the two electrodes of resistance spot welding machine. Due to the joule effect, metal rivets will generate heat and transfer the heat to plastic, leaving the plastic molten. Under the electrode pressure effect, rivets are pressed and deformed, forming securing rivet heads on both ends of plastic sheets. In addition, molten plastics around the rivets are extruded by the electrodes to play an adhesive role. This paper will explore the feasibility of Electric Resistance Hot-driven Riveting by analyzing a case-study joint on ABS thermoplastic.

Experimental Material, Equipment and Method

Experimental Material and Equipment The experimental material was 80mm×25mm×2mm engineering thermoplastic ABS sheet. The rivet material was 6063 aluminum alloy bar at the

dimension of $\Phi 3 \times 8 \text{mm}$. The equipment was Panasonic YF-0201Z2 AC Resistance Spot Welding Machine. NI USB-6008 Data Acquisition Card was used to acquire the experimental data including base material temperature, rivet deformation, electrical current and voltage.

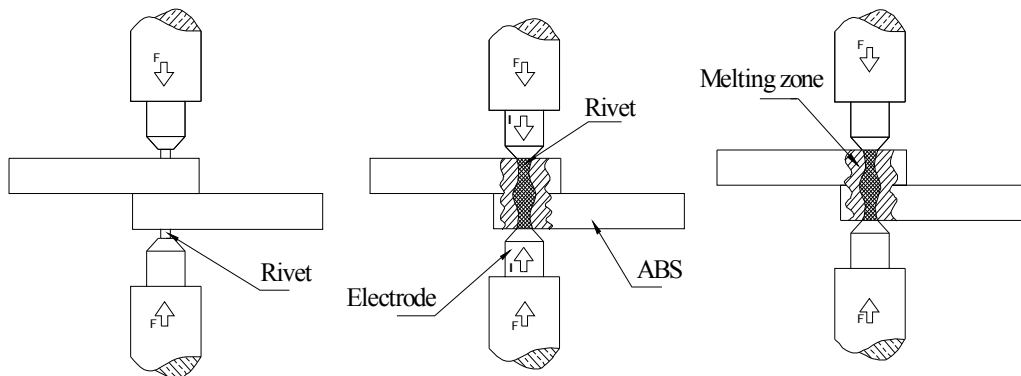

Figure 1: Schematic of riveting process

Experimental Method and Parameter

- I Cut the ABS sheets into standard samples, and punched a $\Phi 3 \text{mm}$ hole in the geometric center of two sheets at the overlap area of $25 \text{mm} \times 25 \text{mm}$. The overlap surfaces are polished slightly with fine abrasive paper and cleaned with absolute ethyl alcohol before riveting.
- I Adhere the thermocouple to the plastic base material 1mm away from the rivet.
- I In this experiment, we mainly studied the effect of electrical current duration and cooling duration (i.e. duty cycle) on the rivet joint performance. Calculate the duty cycle according to the formula (1). See Table 1 for the specific experimental parameters.

$$K = T_w / T = T_w / (T_w + T_c) \quad (1)$$

Where, T_w : electrical current duration; T_c : the cooling duration; T : the cycle^[4].

- I Describe in detail the riveting process through welding the samples at 0.6s, 1.4s, and 8s, analyze and observe the sample morphology in different stages.
- I Tsushima universal experimental machine was used to carry out the tensile experiment on the samples in the sample axial direction at the tensile speed of 1mm/min. For a more accurate study of the effect of processing parameters on the mechanical performance of the riveted samples, it is beneficial to provide five lap shear specimens for each group of parameters, and average the experimental results.

Table 1: Experimental parameters

Press (Mpa)	Current (A)	Electrical current duration (0.02s)	Cooling duration (0.02s)	Duty cycle	Load (N)	Fracture mode
0.3	2500	20	80	1/5	410	Rivet slipping
		20	20	1/2	380	Rivet slipping
		40	10	4/5	425	Rivet slipping
		30	30	1/2	408	Rivet slipping
		50	50	1/2	438	Base material fracture

Experimental Results and Discussion

Riveting Process Analysis Acquisition was completed by the Data Acquisition Card and the LabVIEW-based acquisition system. The relationship between the local plastic temperature, electrode displacement, dynamic resistance and time could be showed in Figure 2. The temperature – time curve could reflect the balanced fluctuation by heating pulse, where the temperature measurement data was lagging and lower due to the thermal inertia and the local measurement point

uncertainty; the electrode displacement- time curve could reflect the rivet deformation trend; the dynamic resistance-time curve could reflect the dynamic resistance change trend from high to low and then slowly increasing, because the contact resistance in the initial power-on stage declined rapidly and the bulk resistance increased after temperature rise. Along with the heating and cooling, there was significant difference in the rivet deformation and plastic temperature at different intervals, so the riveting process could be divided into the T_1 : cold riveting deformation stage, the T_2 : hot riveting molding stage and the T_3 : steady deformation stage.

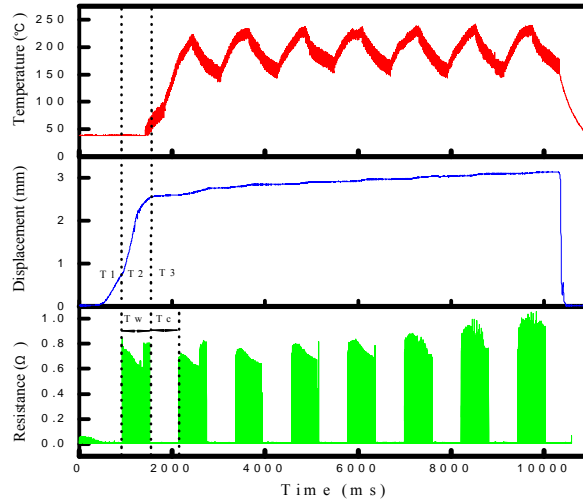

Figure 2: The signal change of temperature, electrode displacement and resistance

The concept of Electric Resistance Hot-driven Riveting is based on the principles of mechanical fastening and resistance welding, where joining energy is supplied by pressure and resistance heat. The process can be schematically represented in Figures 3 (a), (b) and (c), where the three different stages represents the rivet deformation and plastic melting zone extension trends in the entire riveting process.

Figure 3 (a) was the sample riveting morphology in the T_1 cold riveting deformation stage. No power was supplied in this process. The rivets were upset and deformed under the pressure effect at both ends. In this process, the rivet deformation accounted for 23.4% of the total deformation. The plastic was not heated or molten, so no melting zone was formed.

Figure 3 (b) was the sample riveting morphology in the T_2 hot riveting molding stage. This process was the main stage for rivet molding and the key link in the riveting process. The electrodes were powered on. Due to the joule effect, the rivets were heated and softened, with overall deformation under the electrode force, and meanwhile, the plastics around the rivets were heated and molten, forming plastic rings wrapping the metal rivets. Over the power-on time, the molten plastics were constantly extended towards the space between two sheets. In this process, the rivet deformation accounted for 57.6% of the total deformation.

Figure 3(c) was the sample riveting morphology in the T_3 steady deformation stage. As the riveting process lasted, the rivets were still upset. At this moment, the local maximum temperature of the plastics was up to 230°C , not exceeding the thermal decomposition temperature of the plastics. Meanwhile, the plastics were constantly molten, under the pressure effect some of them extended towards the space between two sheets to expand its adhesive range. In this process, the rivet deformation accounted for 19% of the total deformation.

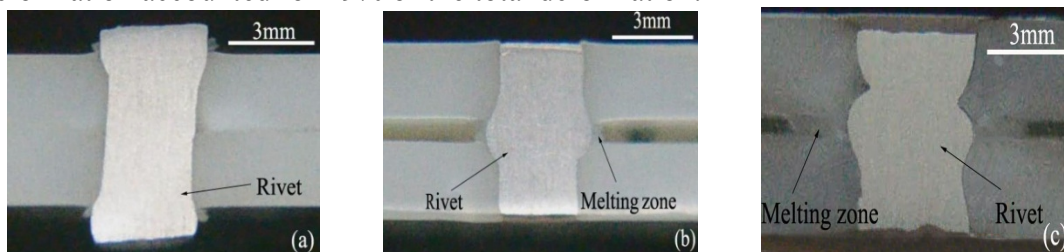

Figure 3: Riveting three samples respectively at 0.6s, 1.4s and 8s , corresponding to (a), (b), (c).

Shear Strength and Joint Fracture Mode As shown in Table 1 for the tensile experimental results, when the duty cycles were 1/5, 1/2 and 4/5. The table allowed the following general trends to be identified: the longer duty cycles, the higher load of the joint could be achieved, because with current electrical duration increasing, the amount of melt penetration and the rivet deformation would increase due to the electrode pressure effect and the joint strength would also increase [5]. When the duty cycle was 1/2, as the electrical current duration increased, the deformation at both ends of the rivets and the local plastic melting would also increase, so the joint strength would increase.

See Table 1 for the joint fracture modes at different duty cycles. See Figure 4 for the tensile curves for the two typical joint fracture modes and the corresponding joint fracture samples. In Figure 4 (a), the electrical current duration is 1s, and the cooling duration is 1s; the joint fracture mode at the duty cycle of 1/2 is base material fracture. Based on the tensile testing curves and the fracture morphologies, when the fracture surfaces are observed, a large stressed-whitened zone and bending deformation is visible in tested specimens. When the stress reaches the peak, due to the stress concentration, the base material around the rivets undergoes microcrack, micropore and other defects, and under the continuous stress effect, brittle fracture occurs to the base material [6].

In Figure 4 (b), the electrical current duration is 0.4s, and the cooling duration is 1.6s; the joint fracture mode at the duty cycle of 1/5 is rivet slipping. In the fracture process, under the tension effect, base material undergoes stress whitening. When the stress reaches the peak, due to the stress concentration, the base material around the rivets undergoes craze. However, craze consumes a lot of energy in the forming and growth process, and restrains the crack propagation, so that the base material ductility is increased. At this moment, under the tension effect, rivet deformation increases, forming crack source, resulting in slow ductile fracture.

Based on the tensile results, the maximum sample tensile strength is 438N, accounting for 79% of base material strength. The strength is significantly increased compared to that in the traditional plastic connection technique. therefore, Electric Resistance Hot-driven Riveting joint has the advantages of high mechanical strength and high reliability.

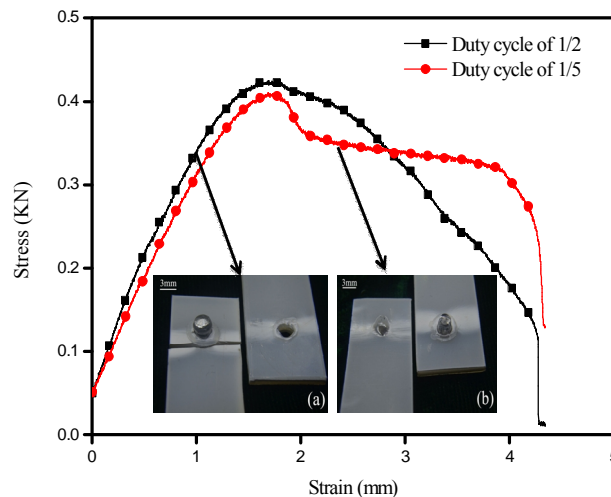

Figure 4: Joint stress-strain curve and joint fracture morphology at duty cycles of 1/2 and 1/5

Conclusion

(1) Electric Resistance Hot-driven Riveting combines the characteristics of machine riveting, gluing and welding, and is a reliable thermoplastic connection technique.

(2) Based on the amount of the rivet deformation and the plastic melting zone, the riveting process can be divided into three stages of cold riveting deformation, hot riveting molding and steady deformation, which in the hot riveting molding stage that is a key stage in the entire process,

the rivet deformation is up to 57%, and the molten plastics extend towards the sheets under the electrode effect, forming a melting zone, with a gluing effect on the joint.

(3) When the duty cycles are identical or different, as the electrical current duration increases, the rivet deformation will increase, and the melting zone that plays an adhesive role for the joint will be enlarged, so that the joint strength will also increase. Joint fracture mode includes brittle fracture when base material failure and ductile fracture when rivet failure. The maximum strength of the joint can be up to 79% of that of the base material.

Reference

- [1] Dalong Gao, Ugur Ersoy, Robin Stevenson. A New One-Sided Joining Process for Aluminum Alloys: Friction Stir Blind Riveting, *J. Journal of Manufacturing Science and Engineering*. 131 (2009) 1-12.
- [2] Faruk Sen, Kemal Alda. Effects of Using Different Metal Materials on Stresses in Metal-Composite Hybrid Joints, *J. Cankaya University Journal of Science and Engineering*. 8 (2011) 1—13.
- [3] S.T. Amancio Filho. FRICTION RIVETING: development and analysis of a new joining technique for polymer-metal multi-material structures, *J. WELDING IN THE WORLD*. 55 (2011) 14—24.
- [4] CHRISTOPHE AGEORGES and LIN YE. Simulation of Impulse Resistance Welding for Thermoplastic Matrix Composites, *J. Composite Materials*. 8 (2001) 133–147.
- [5] M. HOU, L. YE and Y.-W. MAI. An Experimental Study of Resistance Welding of Carbon Fibre Fabric Reinforced Polyetherimide (CF Fabric/PEI) Composite Material. *Composite Materials*. 1999, vol. 6, 35-49.
- [6] K. Dijkstra, J. ter Laak. Nylon-6/rubber blends: 6. Notched tensile impact testing of nylon-6/(ethylene-propylene rubber) blends. *Polymer*. 1994, vol. 35, 315-332.