

# The Rebar Strains Performance Test and Research of All-lightweight Aggregate Concrete Beam-column node under the earthquake action

Yanmin Yang, Runtao Zhang and Bo Qu

(School of Civil Engineering, Jilin Jianzhu University, Changchun, 130118)

**Keywords:** the all-lightweight aggregate concrete; frame beam-column node; joint core; rebar strains

**Abstract.** Under the different axial compression ratios, testing the two intermediate nodes low cycle loading of the all-lightweight aggregate concrete frame beam-column node. Research the aseismic performance of all-lightweight aggregate concrete frame beam-column node. Analyse the rebar strains of beam-end and joint core under the earthquake action of all-lightweight aggregate concrete frame beam-column node. Evaluation the seismic performance of all-lightweight aggregate concrete frame beam-column node.

## Introduction

The all-lightweight aggregate concrete as a branch of lightweight aggregate concrete, is composed of lightweight aggregate (ceramsite), light fine aggregate (pottery sand), cement, water and some chemical admixtures<sup>[1]</sup>. It has advantages of light weight, high strength, seismic resistance, fire-resistant thermal insulation, etc. Based on the existing frame beam-column node of theoretical research, taking low cycle loading test on the all-lightweight aggregate concrete frame beam-column nodes. Research the rebar strains of all-lightweight aggregate concrete frame beam-column beam-end and joint core. Analysing the application feasibility of the all-lightweight aggregate concrete as a supporting member in multi-storey building.

## Testing program

### Specimen design

Considering the different axial compression ratio on the influence of the seismic performance on the all-lightweight aggregate concrete frame beam-column node. The test uses the middle layer of beam-column joints as the research object under a multilayer frame structure in horizontal seismic action, according to design principles of strong column-weak beam, strong node, weak artifacts<sup>[2]</sup>, designed two all-lightweight aggregate concrete frame beam-column intermediate node specimens, the all-lightweight aggregate concrete strength is LC30. The longitudinal rebar of beam and column are HRB400, the stirrup of beam, column and node are HRB300. Specimen size, reinforcement design and number are shown in figure 1 and table 1.

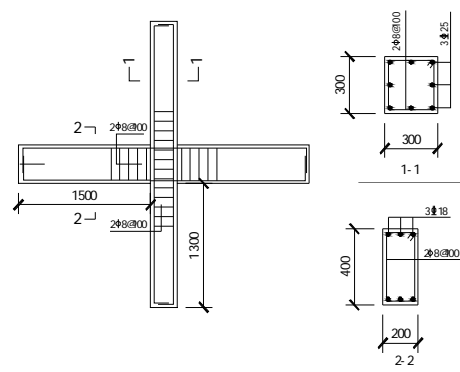

Fig.1. Rebar of beam-column node

Table 1 The design parameters of each specimen

node types	specimen number	beam-end reinforcement(mm)		column-end reinforcement ( mm )		joint core stirrup(mm )	design axial compression ratio
		longitudinal rebar	stirrup	one side of longitudinal rebar	stirrup		
intermediate node	ZJD-1	top and bottom $3\Phi 18$	$\Phi 8@100$	$3\Phi 25$	$\Phi 8@100$	$5\Phi 8$	0.1
	ZJD-2	top and bottom $3\Phi 18$	$\Phi 8@100$	$3\Phi 25$	$\Phi 8@100$	$5\Phi 8$	0.3

**Design of loading scheme**

Using the MTS electro-hydraulic servo hydraulic loading system for antisymmetric loading on beam-end. The loading device is shown in figure 2. The loading system uses the displacement loading control, the test use 2mm as the load increment, each stage loading takes two loops. When loaded to failure load (85% of the ultimate bearing capacity), concluded that specimen failure and end the test.

**Testing point arrangement**

Use the British IMP data acquisition system to collect rebar strains. Measuring the strains of joint core stirrup and longitudinal rebar. Measuring the strains of longitudinal rebar and stirrup that near the nodes within the scope of the length of the beam-end  $hb$  (the section height of the beam). Testing point arrangement is shown in figure 3.

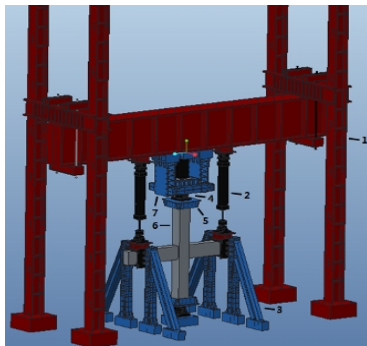

1-reaction frame ; 2-MTS actuator ; 3-the protection of out-of-plane lateral support ; 4- ball-hinge ; 5- the stationary connector at the column-end ; 6-the specimen ; 7-the vertical horizontal support

Fig.2. The loading device

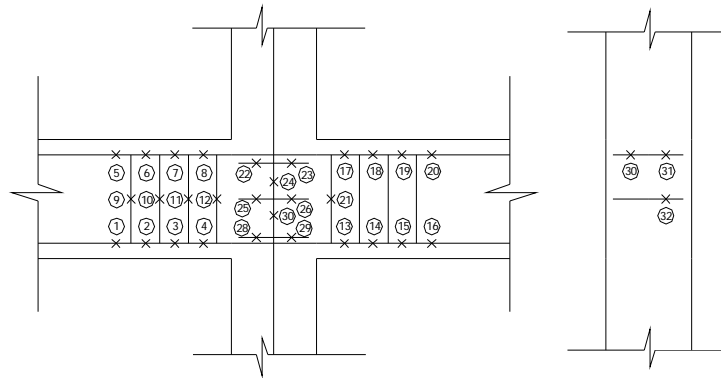

The rebar measuring point arrangement of the ZJD-1 and ZJD-2

Fig.3. The reinforcement measuring point arrangement

**Testing results analysis**

According to the test results, sorting and analysing each specimen's rebar strains of beam-end and joint core. Analysing the rebar force situation in the process of test, the influence of different

axial compression ratio on specimens rebar rebar stress.

### Beam-end rebar strain measuring point analysis

#### Beam-end longitudinal rebar strain measuring point analysis

Sorting and analysing each specimen's rebar strains of measuring point 8 on beam-end, is shown in figure 4. Through the comparison and analysis of each specimen's load - strain curve shows:

(1) Under the reciprocating loading, rebar strains appear the alternation of plus and minus, shows that rebar are in tension and pression. At the beginning of the load (before the concrete cracking), the load-strain relationship of measuring points vary linearly and have no obvious hysteretic loops; with the load increased, the concrete cracking, rebar appears the residual strain, the load-strain relationship of measuring points vary non-linearly, and appear hysteretic loops.

(2) The specimen's strain of ZJD-1 is between  $-1000\mu\epsilon \sim 1500\mu\epsilon$  and the specimen's strain of ZJD-2 is between  $-600\mu\epsilon \sim 1800\mu\epsilon$ , they showed that axial compression ratio increased, the rebar residual strain increases. Due to the axial compression ratio increases limits the rotation capacity of beam-column joints, the plastic hinge transfers to beam-end, and the plastic hinge area increased, beam longitudinal rebar strain increased.

(3) Due to the concrete cracking, bonding between concrete and rebar occurred failure, load-strain curve appeared a certain degree of jumping.

#### Beam-end stirrup strain measuring point analysis

Sorting and analysing each specimen's rebar strains of measuring point 12 on beam-end, is shown in figure 5. Through the comparison and analysis of each specimen's load-strain curve shows:

(1) Due to the test loaded on the beam-end, beam-end cracking earlier, the residual strain of beam-end stirrup appears earlier, and the stirrup is basic in a state of tension.

(2) During the  $40\text{kN} \sim 50\text{kN}$ , each specimen appeared the residual strain and hysteretic loops obviously. With the load increased, the stirrup strain increased quickly, then the area of the hysteresis loops increased. It shows that beam-end concrete cracking because of tension, appeared diagonal cracks, bonding between concrete and stirrup occurred failure, then the stirrup began to play a major role.

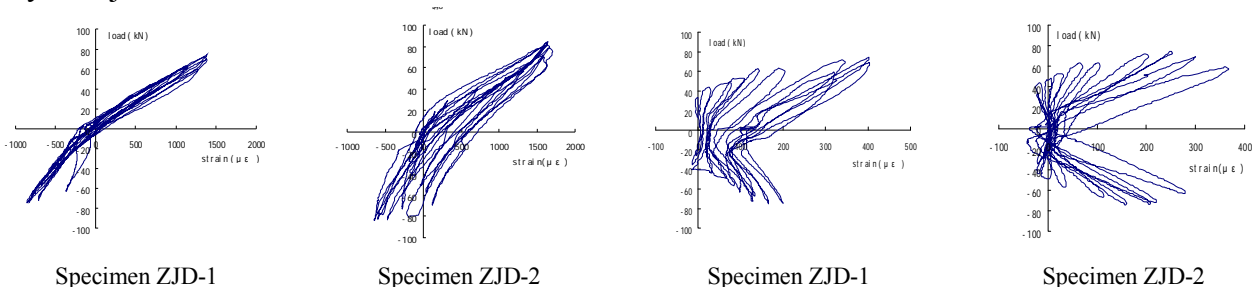

Fig.4. The load-stain curve of the longitudinal rebar on beam-end

Fig.5. The load-stain curve of the stirrup on beam-end

### Joint core rebar strains measuring point analysis

#### Joint core column longitudinal rebar strains measuring point analysis

Sorting and analysing rebar strains of measuring point 24, is shown in figure 6. Through the comparison and analysis of each specimen's load-strain curve shows:

(1) At the beginning of the load (before the joint core concrete cracking), the load-strain

relationship of measuring points vary linearly;with the load increased,the joint core concrete cracking,rebar appears the residual strain,the load-strain relationship of measuring points vary non-linearly,and appeared hysteretic loops.

(2)Joint core column longitudinal rebar strains had no obvious jumping,it showed that the joint core concrete cracking had no significant effect on the column longitudinal rebar.

(3)The specimen's strain of ZJD-1 is between  $0\mu\epsilon \sim 1900\mu\epsilon$  and the specimen's strain of ZJD-2 is between  $0\mu\epsilon \sim 1800\mu\epsilon$ ,they showed that axial compression ratio had no effect on the column longitudinal rebar.

### Joint core stirrup strains measuring point analysis

Sorting and analysing rebar strains of measuring point 25,is shown in figure 7.Through the comparison and analysis of each specimen's load-strain curve shows:

(1)Each specimen's rebar strain,is positive number,showed that during the process of test,the joint core stirrup were always in a state of tension.At the beginning of the load,the load-strain relationship of measuring points varied linearly and had no obvious hysteretic loops; with the load increased,the joint core concrete cracking,rebar appeared the residual strain,the load-strain relationship of measuring points varied non-linearly,and appeared hysteretic loops.

(2)The change from of joint core stirrup strains were basically the same,the specimen appeared shear failure on joint core,the load-strain relationship of joint core stirrup appeared jumping obviously and had many catastrophe points.

(3)The specimen's strain of ZJD-1 is between  $0\mu\epsilon \sim 2400\mu\epsilon$  and the specimen's strain of ZJD-2 is between  $0\mu\epsilon \sim 6500\mu\epsilon$ .They showed that axial compression ratio had no effect on the column longitudinal rebar.The jumping of the joint core stirrup strain of the specimen ZJD-2 is bigger than the specimen ZJD-1,it showed that axial compression ratio increased,binding effect of the joint core increased.But once the concrete cracking and breaking,stirrup strain appeared mutation obviously<sup>[3]</sup>.

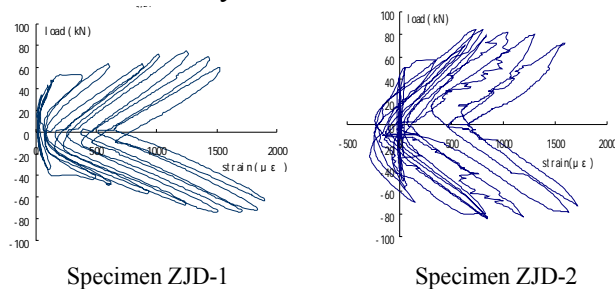

Fig.6. The load-stain curve of the joint core column longitudinal rebar strains

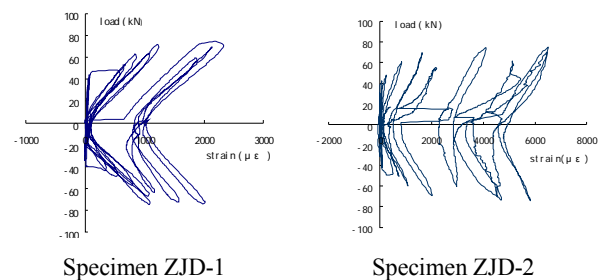

Fig.7. The load-stain curve of the joint core stirrup

### Conclusion

(1)In this paper,research the aseismic performance of all-lightweight aggregate concrete frame beam-column node,the test results showed that,according to the existing specification<sup>[4]</sup> design,the development rules of load-strain on the joint core and plastic hinge area meet the requirements of the structural stress.

(2)The axial compression ratio had no effect on the joint core column longitudinal rebar.But axial compression ratio increased,binding effect of the joint core increased,once the concrete

cracking and breaking, stirrup strain appeared mutation obviously, then beam-end longitudinal rebar increased, shear-bearing capacity was improved.

(3) Setting up hinged supports on the top and bottom of the column to make sure the column-end are hinge constraints; and set the protect supports that has universal ball joint in case out of plane on the beam-end, it can not only produce vertical load, but also have no more constraints on the beam-end, the design of the test device ensures the accuracy of the data.

(4) The research results shows that, the all-lightweight aggregate concrete frame beam-column node has good seismic performance, the application of the all-lightweight aggregate concrete, which is composed of shale ceramsite and pottery sand, as a supporting member in multi-storey building, in theory, is feasible.

### **Acknowledgements**

This work was financially supported by the Jilin Science and Technology Foundation (20150203014SF, 2012200, 2015267).

The authors gratefully acknowledge the Natural Science Foundation of China (No.51378238).

### **References**

[1] China Academy of Building Research. technology specification for Lightweight aggregate concrete ( JGJ51-2002 ) [S]. China building industry press, 2002.

[2] Jinping Xu, Jianhua Chen, Shaohao Zhou. Lightweight Aggregate Concrete Applied Research and Outlook [J]. Science and Technology of Overseas Building Materials. 2007, 28 ( 5 ) : 11-13.

[3] Wenxiang Cheng, Zhongxue Gao. Experimental Study of Frame Joints with Steel Reinforced Concrete Column [J]. Journal of building structures, 2002, 23(4): 36-39.

[4] Building Industry Standard of the People's Republic of China. Building Industry Standard of the People's Republic of China. Technical specification for lightweight aggregate concrete structures, (JGJ12-2006) [S]. Beijing: Ministry of Construction, P. R., 2006.