

Design of multi-channel automatic switch high precision low voltage change-over switch

Bing Zhou^{1,a*}, Jing Hui Zhao^{1,b}

¹Instrumentation Department, Liaoning Jidian Polytechnic, Dandong City, Liaoning Province, 118009, China

^a1304269@163.com, ^bJinghui_zhao@163.com

Keywords: multi-channel, automatic switch, high precision, low voltage, change-over switch, design

Abstract. There is a kind of multi-channel automatic switch high precision low voltage switch. The conversion axis of low potential automatic change-over switch has public contact. The public contact and indexing plate's each indexing position contact constitute the multi-channel change-over switch. Stepper motor driver connects conversion axis. The control of stepper motor includes stepping motor drive and control department. The control department includes pulse output unit, PCI-1716 series data acquisition card and output connecting stepper motor drive's drive unit. The one digital output terminal of PCI-1716 series data acquisition card is motor direction control terminal which connects to the one drive channel inputs of drive unit; the other digital output terminal of PCI-1716 series data acquisition card is bearing drive unit start signal which connects to drive unit. Ensure the parasitic potential of multi-channel automatic transfer switch is not more than $1\mu\text{V}$. Realize the multi-channel thermocouple data automatic measurement when testing the industrial thermocouple.

1 Introduction

Change-over switch of multi-channel automatic switch high precision low voltage (Change-over switch for short) is the necessary conversion device of multiple thermocouple millivolt measurement when testing the thermocouple. Take a test cycle including a number of thermocouples switch for example. Currently, multiple thermocouples in a group constitute the corresponding numbers of test channel; each channel requires the change-over switch to transfer between various test channels. The test channel of selection connects to data acquisition respectively, and then completes the verification process. But the existing multi-channel switch's operation is only for manual. Manual operation leads to test low efficiency, time-consuming, error-prone, calibration precision may difficult to guarantee^{[1][2][3]}.

2 Change-over switch hardware design principle

2.1 Change-over switch system principle

Change-over switch system principle is shown in Fig. 1

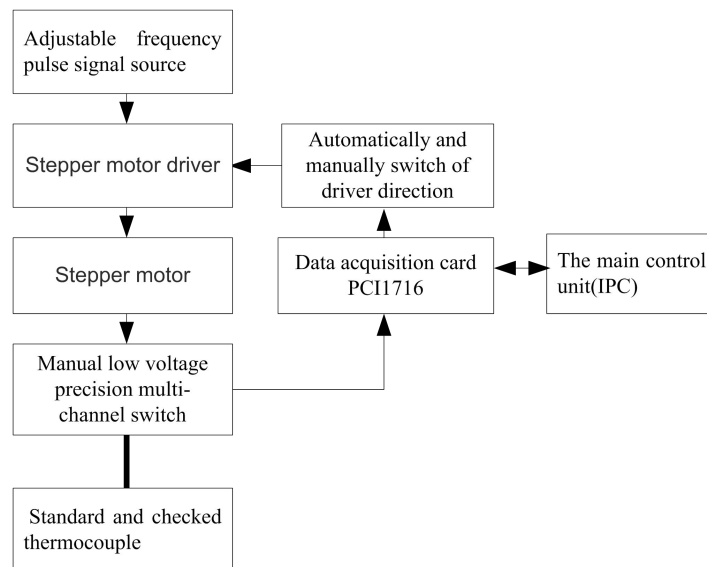

Fig. 1 Change-over switch system principle

One role of adjustable frequency pulse signal source is to control stepper motor step length and speed, another role is to determine the location and position of automatic transfer switch. Stepper motor driver is a kind of actuator transfer electrical pulses into angular displacement. When stepper driver receives a pulse signal, it drives stepper motor according to setting direction to rotate a fixed point (called "step angle"). Its rotation operates through fixed angle step by step. It can be controlled the number of pluses by controlling the angular displacement, so as to achieve the purpose of accurate positioning; it also can be controlled the pulse frequency by controlling motor rotation speed and acceleration, so as to achieve the purpose of speed regulation and positioning.

Manual low voltage precision change-over switch is used to test multiple checked thermocouples conversion. It is mainly used for the standard thermocouple and working thermocouple conversion in the measurement; by manual operation or control of standard interface, any converters of this switch can be connected to output. Switch contacts have low thermoelectric power (less than 0.4 microvolt). Data acquisition card PCI1716 is used to measure automatically control when used to automatic test multiple checked thermocouples.

2.2 Stepper motor and low voltage precision change-over switch principle

Stepper motor and manual low voltage precision change-over switch mechanical connection principle is shown in Fig.2

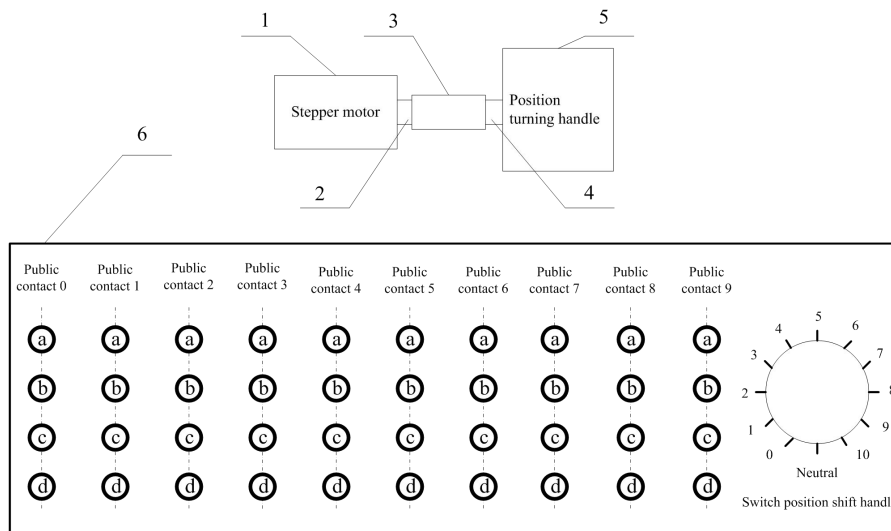

Fig.2 Stepper motor and manual low voltage precision change-over switch mechanical connection principle

1-Stepper motor; 2-Stepper motor drive shaft; 3-Stepper motors and low potential precision change-over switch connection set;4- Low potential precision change-over switch position conversion connection shaft;5- Low potential precision change-over switch position shift handle;6- Low potential precision change-over switch contact

1) Low potential precision change-over switch principle:

When low potential precision change-over switch position shift handle,

(1) at the dynamic contact 1 position: Public contact 0's a, b, c, d contact connected to moving contact 1's a, b, c, d contact

(2) at the dynamic contact 2 position: Public contact 0's a, b, c, d contact connected to moving contact 2's a, b, c, d contact

(3) at the dynamic contact 3 position: Public contact 0's a, b, c, d contact connected to moving contact 3's a, b, c, d contact

And so on

(4) at the Dynamic contact9 position: Public contact 0's a, b, c, d contact connected to moving contact 9's a, b, c, d contact

2) Automatic control principle:

The number of pulse frequency between public contact 0 and dynamic contact 1, dynamic contact 1 and dynamic contact 2, dynamic contact 2 and dynamic contact 3, dynamic contact 3 and dynamic contact 4, dynamic contact 4 and dynamic contact 5, dynamic contact 5 and dynamic contact 6, dynamic contact 6 and dynamic contact 7, dynamic contact 7 and dynamic contact 8, dynamic contact 8 and dynamic contact 9's rotation process can be tested in advance. In such automatic control, as frequency for reference, you can know contact position of the low potential precision change-over switch in automatic conversion, to achieve automatic detection multiple thermocouples' thermoelectric power value.

2.3 Adjustable frequency pulse signal source, stepper motor driver and the data acquisition card PCI-1716 principle

Adjustable frequency pulse signal source, stepper motor driver and the data acquisition card PCI-1716 principle is shown in Fig.3.

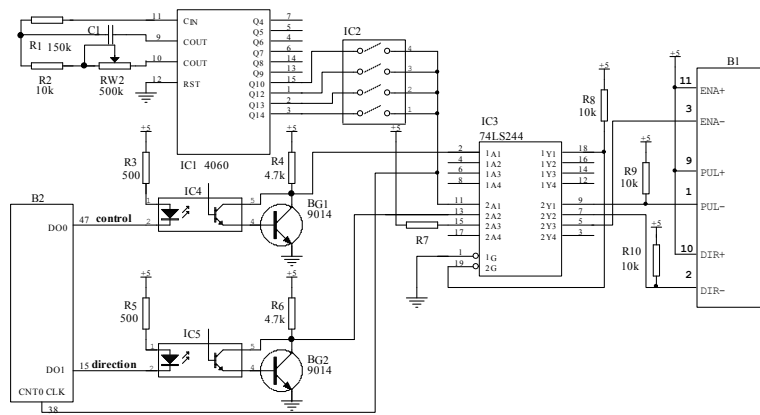

Fig.3 Adjustable frequency pulse signal source, stepper motor driver and the data acquisition card PCI-1716 principle diagram

R1, R2, C1, RW2, IC1, IC2, R3, R4, IC3, BG1, R5, IC4, R6, BG2, R7, IC3, R9, R10 constitute adjustable pulse frequency control circuit. B1 is stepper motor driver wiring circuit. B2 is data acquisition card PCI-1716 wiring circuit. The working principle is IC1 pulse frequency generator circuit. RW2 adjustable potentiometer and multiplexer IC2 achieve pulse frequency adjustment. R3, R4, IC3, BG1, R5, IC4, R6, BG2, R7, IC3, R9, R10 constitute control circuit.

1) B1 stepper motor driver

1pin and 9 pin are pulse signal input terminal, when single pulse control method change to pulse control signal, the pulse rising edge is effective; when double pulse control method change to forward pulse signal, the pulse rising edge is effective. 2 pin and 10 pin are direction signal input terminal, single pulse control method for high/low level signal, double pulse control method for the inversion pulse signal. Pulse rising edge is effective. 3 pin and 11 pin enabling signal input terminal are used to enable/ban, when high level enabling, at low electric, the driver cannot work.

2) B2 data acquisition card PCI-1716

38 pin is pulse count input; 47 pin is digital output control 0 terminal, when low electric, the pulse modulation circuit can work. 13 pin is digital output control 1 terminal, when high electric, it make driver control stepper motor corotation; when low electric , it make driver control stepper motor reversal.

3 Change-over switch software design principle

3.1 change-over switch program block diagram

Change-over switch program block diagram is shown in Fig.4

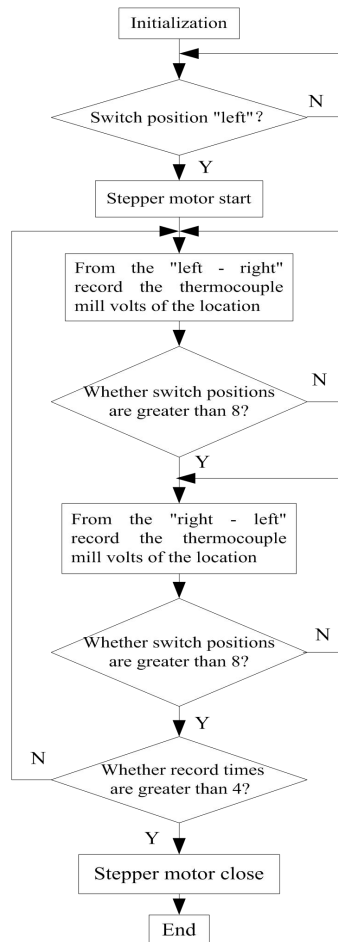

Fig.4 Change-over switch program block diagram

Software design uses the graphical program compiled platform developed by the National Instruments, LabVIEW (Laboratory Virtual Instrumentation Engineering Workbench. It combines with the database and reporting toolkit to complete the design system of thermocouple calibration software.

3.2 change-over switch program design (omitting)

4 Experimental test

(1) Instrument and equipment required for the test: tube furnace's length is 600 mm and the heating tube is 40 mm. Reference to the end thermostat, the temperature of thermostat is $(0 \pm 0.1)^\circ\text{C}$. The standard thermostat, a platinum and rhodium 10 - platinum (S-type). The checked thermostat, seven nickel chromium - nickel silicons (K type). The K-type thermocouples' electrode diameter is $\phi 1.0$, the accuracy grade is I level, error is 1.6°C . The test temperature point is 400°C .

(2) Test procedure: when the furnace temperature is raised to test point temperature and temperature change less than $0.2^\circ\text{C} / \text{min}$, each checked thermocouple's thermal emf will be measured start from the standard thermocouple. Measurements as follow:

The reading should be quickly and accurately, the interval should be similar, the measurement reading should not be less than four times. During test, the tube furnace temperature should no more than $\pm 0.5^\circ\text{C}$ ^[4].

(3) The test results as the original records are shown in Table 1; the test result error calculation is shown in table 2.

Table 1 Test results as the original records (unit: mv)

	First measurement value	Second measurement value	Third measurement value	Forth measurement value	the average of four times
standard thermocouple	3.34402	3.33236	3.34133	3.33694	3.33866
Checked 1	16.6882	16.7084	16.7147	16.7175	16.7072
Checked 2	16.6936	16.6929	16.6903	16.6912	16.692
Checked 3	16.7092	16.7028	16.7005	16.7026	16.7038
Checked 4	16.7224	16.7327	16.7412	16.7404	16.7342
Checked 5	16.6881	16.694	16.7045	16.7063	16.6982
Checked 6	16.7079	16.7119	16.7217	16.7218	16.7158
Checked 7	16.6928	16.7074	16.7169	16.7248	16.7105

Above 300 °C thermal EMF error Δe uses the following formula^[5]:

$$\Delta e = \bar{e}_1 + \frac{e_2 - \bar{e}_3}{S_1} \cdot S_2 - e_4$$

In the formula:

\bar{e}_1 — under the temperature of some test point nearby, the checked thermocouple measured the thermoelectric emfs arithmetic mean

e_2 — the thermal emf value of some test point temperature on standard thermocouple certificate

\bar{e}_3 — under the temperature of some test point nearby, the standard thermocouple measured the thermoelectric emfs arithmetic mean

e_4 — the thermal emf value of some test point temperature on checked thermocouple indexing table

S_1 、 S_2 — respectively representing the standard and checked thermocouple at the differential thermoelectric emf of some test point

When nickel-chromium - nickel silicon (K-type) at 400 °C test point, the above equation's constants are as follows:

$e_2=3.258$; $S_1=0.00957$; $e_4=16.397$; $S_2=0.04224$; the difference between the standards and occasionally check point=-0.35602。

Table 2 the test result error calculation

No.	\bar{e}_1	Actual value(mv)	error(mv)	Corrected value(°C)	Test result
1	16.7072	16.35118	-0.04582	1.0848	pass
2	16.692	16.33598	-0.06102	1.4446	pass
3	16.7038	16.34778	-0.04922	1.1652	pass
4	16.7342	16.37818	-0.01882	0.4455	pass
5	16.6982	16.34218	-0.05428	1.285	pass
6	16.7158	16.35978	-0.03722	0.8812	pass
7	16.7105	16.35448	-0.04252	1.0066	pass

From table 1 and table 2's data records and the calculation results, multi-channel high precision low voltage change-over switch's performance completely conform to the requirements of the thermocouple calibration procedures.

5 Conclusions

Multi-channel switching precision low potential switch is an essential means of thermocouple automatic verification. Its innovative point is that by stepper motor and driver to drive low potential precision switch manually turn the handle, through two required switch point between the rotation frequencies as a benchmark for automatic control. It finally reaches multiple thermocouple calibration data automatic measurement.

Acknowledgements

This work was financially supported by the Dan dong Natural Science Foundation (12206) and Industrial and technological project of Dan dong Municipal Science and Technology Bureau (12206).

References

- [1] Jinghui Zhao. Change-over switch of multi-channel automatic switch high precision low voltage .China. 201520291590.8[P].2015-05-08.
- [2] Information on <http://www.scientific.net/AMM.303-306.588>
- [3] Information on <http://www.scientific.net/AMM.511-512.529>
- [4] Information on <http://www.scientific.net/AMR.706-708.742>
- [5] Working inexpensive metal thermocouple calibration procedures JJG351-1996. China metrology press,2010

Author profile: (1) ZHOU BING (1964-), male, the professor-level senior engineer, Liaoning Jidian Polytechnic, main research on instruments and test device, Dandong City, Liaoning Province, 118009. E-mail: 1304269@163.com. Mobile phone: 15842570501.

(2) ZHAO JING-Hui (1963-), male, Professor, Liaoning Jidian Polytechnic, main research on the computer measurement and control technology. Dandong City, Liaoning Province, 118009. E-mail: Jinghui_zhao@163.com.