

General Study on the Construction and Installation of Jacket Skirt Pile Sleeve

Shi Jicheng^{1, a}, Lian Xin^{1, b}, Wu Yiwen^{1, c}, Shang Jifei^{1, d} and Shen Yuji^{1, e}

Qingdao Economic and Technical Development Zone, Shangdong, China

^ashijc@mail.cooec.com.cn, ^blianxin@mail.cooec.com.cn, ^cwuyw1@mail.cooec.com.cn

^dshangjf@mail.cooec.com.cn, ^eshenyj@mail.cooec.com.cn

KEY WORDS: Offshore Engineering, Jacket, Jacket skirt pile sleeve, Lift

ABSTRACT: As time enters 21st century, the world enters the era of oil scarcity, which is the so-called "post-oil era." Onshore exploration peak period has expired; the energy gap gradually expanded into the marine transfer is the trend. The main forms of offshore platforms are: jacket platforms, jack-up rigs, semi-submersible drilling platforms and floating vessels. Wherein the jacket fixed platform as the domestic and international manufacturing and plays an important role in the offshore oil and gas resource development. The skirt pile sleeve as one of the most important parts of the jacket, the study of its construction and installation has a very important significance. This article will detail the construction and installation of jacket skirt pile sleeve.

Introduction

Background

The exploit duration for the oil and gas is estimated 30 to 80 years. With the rapid demand, the focus has shifted from the onshore to the ocean exploit. The reservoir of the ocean oil takes 34% of the whole earth. The numbers of offshore wells exceeds 60% of the recent found large wells. Besides, the reservoir of ocean is 0.16 billion barrels, which makes the ocean exploit field more promising.

Petroleum and gas will still be the vital energy resource in the worldwide. The peak time of the onshore exploit has passed and the focus will be shifted to the ocean oil field with the energy demands growing. The platform based on pile skirt sleeve jackets is the most employed in the offshore filed, which plays a significant role in the energy exploit. As a structure part, the construction and installation research of skirt pile sleeve has very realistic meaning. This paper will state the process of construction and installation.

General information of Skirt Pile Sleeve

The skirt pile sleeve connects and jacket, which is structured with pipes and plates. It can transfer the platform load to the piles. However, some platforms' pile will be installed from the jacket legs, which require no skirt pile sleeves. Some jackets required both internal pile and pile sleeves

There are some special items in the skirt pile sleeves

- Ø Weld bead .This item is the between the internal sleeve and outer surface of pile ,which is to strengthen the connection
- Ø Shim , this item is welded to the internal sleeve to minimize the gap between the piles and sleeves ,which can help the pile driving.
- Ø Shear plate ,yoke plate ,skirt plate
- Ø Sleeve Guide ,this item is used to guide the pile into the sleeve
- Ø Pile Gripper: the function of this item is to fasten the piles. During the process of pile driving, the gripper will be activated to fasten the pile when encountering the strong wind. Also, the grippers maintain the stability of the pile in the seawater and guarantee the pile lock effect.^[1]
- Ø Packer wiper , this item lies in the bottom of the sleeves, which include outer rubber and air bag next to the internal piles. The function of the packer wiper is to avoid the discharging during the

grouting. The air bag will be aerated with nitrogen by the pipelines and then hold the pile once the pile is driven to the sleeves.



Fig. 1 details of weld bead



Fig. 2 packer wiper



Fig. 3 pile sleeve unit

Prefabrication of the skirt pile sleeve

Prefabrication flow

The skirt pile sleeves normally consists of tube ,yoke plate ,shear plate ,shim plate ,pile gripper and packer wiper. The construction flow will be as follows. [2]

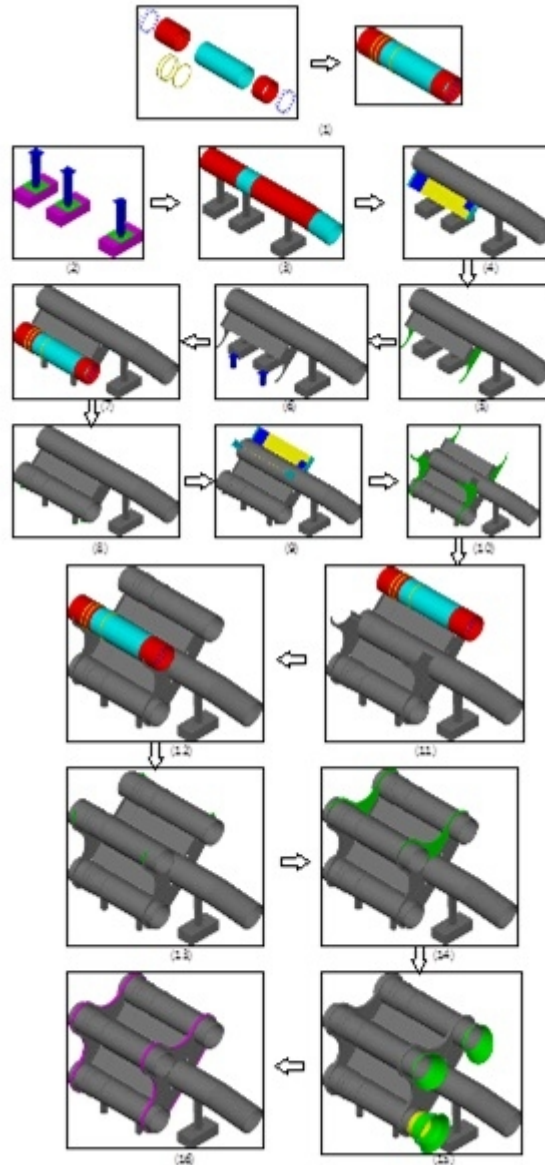

Fig. 4 prefabrication flow

Prefabrication

The process of prefabrication will have slight distinctions between different projects. The following example serves as a reference.

Prefabrication and layout of temporary stool

Lay out the temporary stools in the designated prefabrication areas

steps of the prefabrication

The following steps shall be followed

- 1) Prefabrication of tube
- 2) Layout of temporary stools
- 3) Weld the internal item (IRS、 Bulkhead、 Stiffener)
- 4) Install the shear plate
- 5) Install the first part of yoke plate

- 6) install the temporary supports for the sleeves
- 7) Install the lateral sleeve
- 8) Install the second part of yoke plate
- 9) Install the second part of shear plate
- 10) Install the third part of yoke plate
- 11) Install the second part of the pile skirt sleeves
- 12) Install the third part of the pile skirt sleeves
- 13) Install the fourth part of yoke plate
- 14) Install the fifth part of yoke plate
- 15) install the flange plate
- 16) Install the pile gripper and guides

Install other appurtenances

After the installation of primary structure, complete the pipelines, supports, anodes and finish the erection of scaffold.

Test process

In accordance with the standard requirements, the pile gripper and packer wiper will do perform the related test.^[3]

Installation of skirt pile sleeves

The skirt pile sleeves will be transported to the after the completion of skirt pile sleeve. The lifting plan will be stated due to the size and weight. This paper will use an example to state the process.

3D model setup

Set up the 3D MODEL based on the shop drawings .Basically, there are two model required. , One module is built in Tekla structure software, by which the COG and weight can be assured. Also the model can be used for the clash check. Another model will be built by finite element method software ANSYS , by which the structure stress and pad-eye stress are attained during the lifting .

Pad-eye design

After the finish of the model, the pad-eyes will be designed. This process needs repetitive work. The first step is to choose the lifting trunnion and then verify the lifting stress and deformation of the sleeve. On the condition that the results are satisfactory, the lifting trunnion can be finalized. If not the lifting trunnion and the location will have to be redesigned until it can be met the requirements. The lifting point can be chosen due to the different structure type. The following example is to adopt 6 lifting trunnion ,the dimension of which is all 508×25×200 mm. The material type is CCS DH 36. The barrier plate is 800 in diameter and 25 mm thickness.

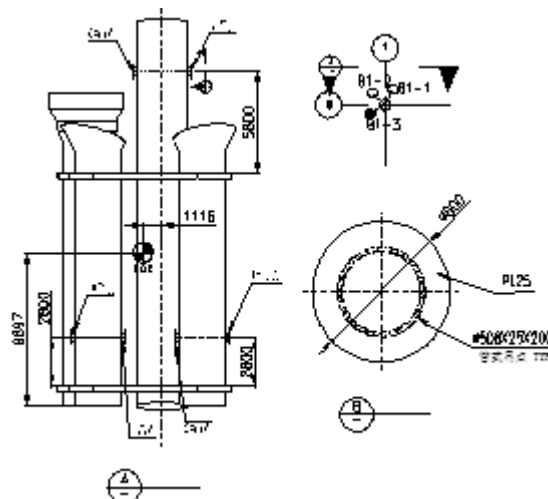

Fig. 5 layout of the lifting trunnions

Structure stress check

After the lifting trunnion has been finished ,the following item shall be checked ,but not limited to :

Ø structure stress check

This step is the most critical one. If the stress check cannot meet the requirement, there are two methods for this scenario, one is to redesign, and other one is to use the temporary supports.

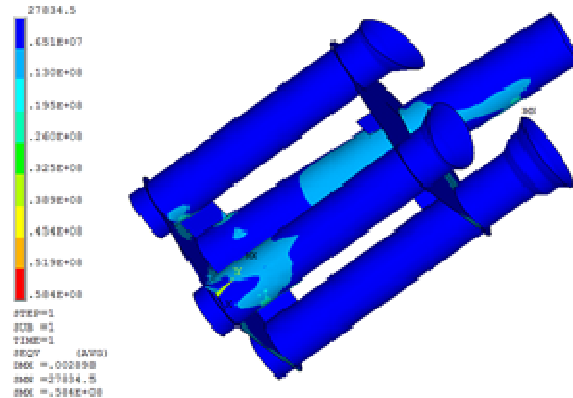

Fig. 6 stress distribution

Ø The structure deformation check

The deformation of the structure is also important. In some cases, the stress can satisfy the lifting load, but the deformation cannot satisfy the requirement.

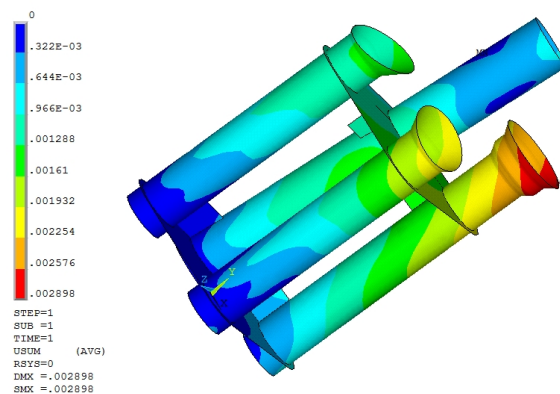

Fig. 7 deformation distribution

Ø stress check

The stress check of the lifting trunnion is based on the reaction and types, normally, there are two methods. One is to use the formula manually; the other is to use the infinite element analysis. This method can be chosen in accordance with the requirement.

Ø the inference of the lifting trunnion during the lifting

The interference is to verify the collision between lifting trunnion and structure as well as the welding seam, which is easily ignore during the design.

Ø crane lifting rate check

This step is to use the reaction data to check whether the crane can meet the lifting load case. If this cannot be met, then the lifting trunnion shall be modified. [4]

Ø space room check

The space check for the crane is also quite important,. Normally, this check is the last step. In some cases .the former checks can be met, but this step is not feasible. The check method is to set up 1:1 scale model to verify. [5]



Fig. 8 space check between crane and structure



Fig. 9 skirt pile sleeve in position

Conclusion

The offshore platform will become large and more complex with the development in the deep water. The fixed pile platform, as the most used in the world, will still play quite important role. As one connection structural piece, which transfers the load from the platform to the pile, the construction and installation of the pile sleeves has a quite important and realistic meaning

References

- [1] Jiang Yi chen ,Tian Yu feng ,Yang Shu geng .Design of pile gripper.china offshore platform Fifth/2008
- [2] Bai Zenglin Bai Xinjian the construction and installation of mega jacket platform. China shiprepair 2007
- [3] Li Qiang the pile sleeve system and field control. Ship standardation engineer 2015/07
- [4] Sun Aiping Yan YongJiang the optimization of the mega equipment lifting plan. Coal technology 2015/03
- [5] Hui Dan Wang Jin. China shiprepair ,the shallow water jacket installion.2015.