

Design of Mine Safety Detection Alarm Based on Single-chip

Mingtao Ma

Jilin College of Agricultural Science and Technology Information Engineering, Jilin 132101, China

mmt800@126.com

Keywords: Single-chip STC89C52; Sensor; Stepper motor; Buzzer; Alarm

Abstract. The design is based STC89C52 single-chip, using MQ-4 ammonia sensor and MQ-7 carbon monoxide sensor, while testing the ammonia and carbon monoxide, when the discovery of the detected gas concentration exceeds a certain concentration, the sensor voltage has changed. Through the LM393 comparator issue the corresponding signal to the single-chip STC89C52 [1]. Then single-chip received signal control stepper motor action, at the same time controlling the buzzer to alarm, reached early warning purposes.

It contains large amounts of methane (CH₄) and other flammable gases in the coal mine, after causing huge economic losses accidents, endangering the lives of miners. Currently the price of combustible gas alarm has been high on the market, and it need to periodically replace the sensor. Therefore, the design of a simple circuit, the relatively low price of a variety of devices to detect underground security alarm, In order to personal and property safety of the people and establish a reliable barrier is very necessary[2].

System Program

According to the basic requirements of design, the system can be divided into three modules, the gas detection module, alarm module and stepper motor operating module (standby module, e.g., self-help function can be further oxygen). The overall system design circuit shown in Fig. 1:

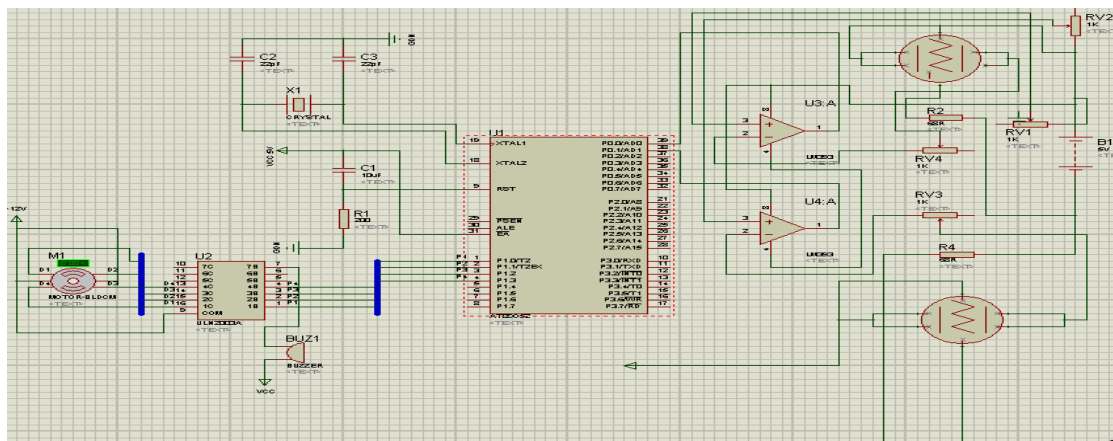

Figure 1. System Circuit Diagram

Hardware Part

The Main Control Chip. Using 52 series single-chip [1] STC89C52 for the control of core components. STC89C52 is STC produced a low-power, high-performance CMOS 8 bit microcontroller with 8K online system programmable Flash memory. STC89C52 using classical MCS-51 core [3], but it have a lot of improvements, making the traditional 51 single-chip has features not available. On a single-chip, 8-bit CPU has a smart and in-system programmable Flash, making STC89C52 provide highly flexible, ultra- effective solution for many embedded control applications.

Gas Detection Circuit Design. Gas sensor detection module consists of gas sensor [3] and comparator. Converted digital signal to the controller after processing the sensor by the controller to the digital processing is completed, the sensor portion using MQ-4 MQ-7 and the test gas concentration, the sensor chip is used as a comparator with LM393P potentiometer sensitivity adjustment to complete gas collection and detection function.

When selecting a specific sensor , taking into account the operating voltage of the sensor , outside temperature adaptation , the sensitivity of the respective gas , whether the environment is suitable to withstand downhole environment , and the service life, so the choice of the sensor to ensure a certain degree of adaptation to the environment ability to be sensitive to a range greater than the range of the gas concentration of gas needed in our system , such products will have a more stable efficiency. Since the output signal of the sensor contains a certain amount of interference noise , it must be on the sensor output signal filtering [4] , in the design of the filter circuit when using an ordinary small capacitor filter out high frequency interference , the use of large electrolytic capacitors to filter out low frequency interference. Electrical sensor output is relatively weak, usually millivolt, very weak is not easy to capture, and so the choice of comparator LM393, by varying the voltage effective value to achieve the objective detection circuit will be more sensitive to this, the efficiency will be higher. Design of the sensor driving circuit [5] shown in Fig. 2:

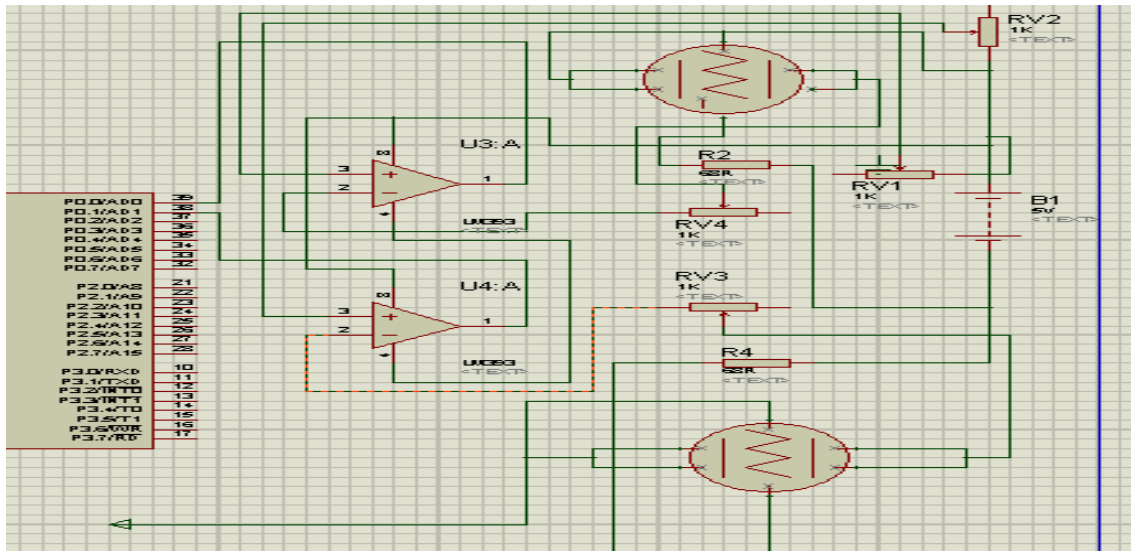

Figure 2. Sensor Drive Circuit Design

Alarm Circuit Diagram. Alarm section adopts the buzzer, alarm using ULN2003 chip drive, when the gas sensor[6] detects gas concentration reaches a certain level, the single-chip microcontroller control chip ULN2003 to control the buzzer. Circuit shown in Fig. 3:

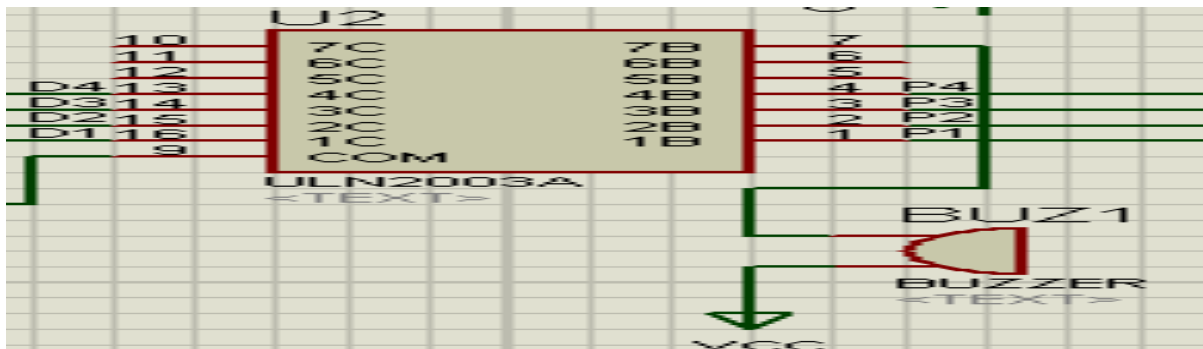

Figure 3. Alarm Circuit

Stepper Motor and Single-chip Circuit Connection Diagram. Stepper motor [7] alarm using ULN2003 chip driver, stepper motor circuit connection as shown in Fig. 4:

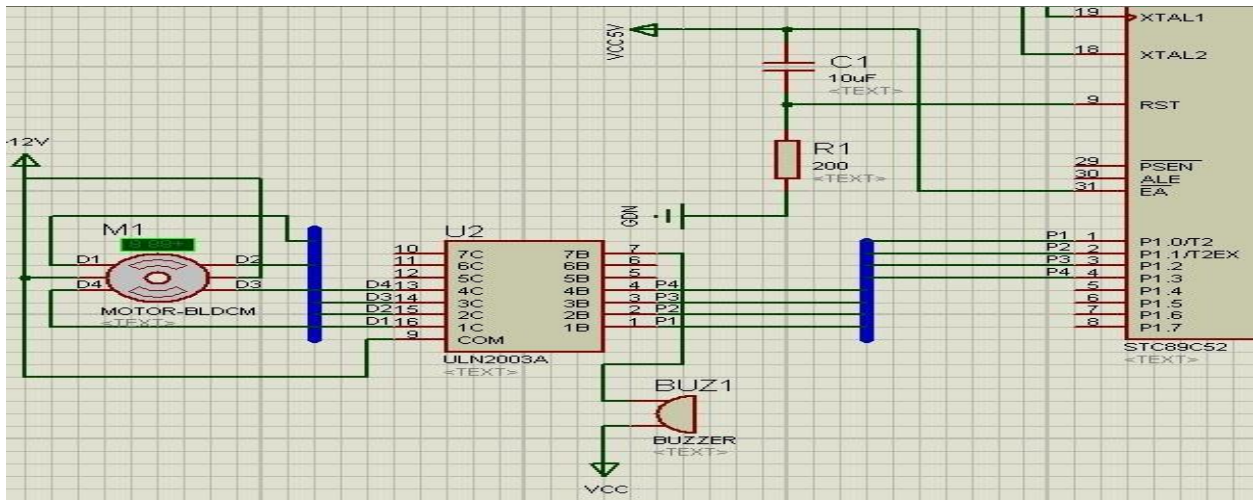

Figure 4. Stepper Motor Circuit Connection Diagram

System Software Design

Main Program Flow Chart. The main program flow chart shows the basic process system works, describes the basic flow of signals, played the role of a wizard [8]. Main system flow chart shown in Fig. 5:

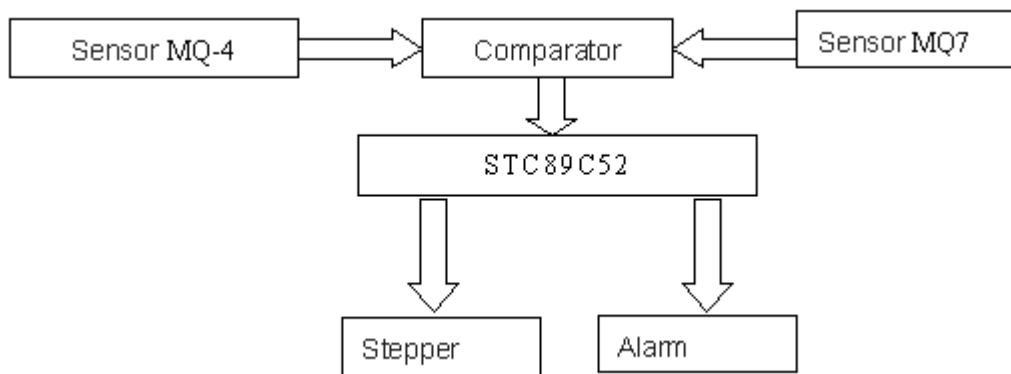

Figure 5. Main Program Flow Chart of System

Signal Sampling and Routine Part of Stepper Motor Design. Stepper motor subroutine mainly refers to the system starts running, the gas is passed over the sensor voltage value by the comparator compares the output signal and passed to the single-chip programming involved [9].

```

Main ()
{
//unsigned int i=64*16; // Stop switch 2 weeks
Speed=3; // Adjust the speed
while(1)
{
Coil_A1 //Encounter Coil_A1 whit {A1=1;B1=0;C1=0;D1=0;}
instead
DelayMs(Speed); // Change this parameter can adjust motor speed,
  
```

```

// The smaller the number, the greater the speed, the smaller the moment
Coil_B1
DelayMs(Speed);
Coil_C1
DelayMs(Speed);
Coil_D1
DelayMs(Speed);
}
}

```

Sensor MQ-4 Subroutine Design.

The main function

*****/

```
void main()
```

```
{
```

```
MQ-7
```

```
while(1) // Infinite loop
```

```
{
```

```
LED=1; // Go Out P1.0 Lamp
```

```
if(DOUT==0) // When the concentration is higher than the set value, the function execution
```

condition

```
{
```

```
delay(); // delay anti-interference
```

```
if(DOUT==0) // Determine the concentration is higher than the set value, the function execution
```

condition

```
{
```

```
LED=0; / LightenvP1.0 Lamp
```

```
.....
```

The single-chip as the core control system[10] , use gas detection sensors and alarm systems to achieve the detection of dangerous gases underground , in order to protect the safety of mine workers . After testing, has been able to complete all of the features described.

References

[1] Wang Xingzhi, AT89 Series Single-chip Principle and Interface Technology [M].Beijing Aerospace Press,2010:45-65

[2] Zhang Yigang, MCS-51 Single-chip Application Design [M] Harbin: Harbin Institute of University Press .2013:142-169

[3] Jia Bonian, Yu Pu, Sensor Technology [M]. Southeast University Press, 2012:33-62

[4] Li Daohua, Li Ling, Zhu Yan, Sensor Circuit Analysis [M], Wuhan: Wuhan University Press, 2010:61-88

[5] Zhao Maota, Principles and Applications of Intelligent Instrument [M] Beijing: Electronic Industry Press, 2004:100-156

[6] Zhang Yikun. Chip microcomputer principle and application [Z] Shan xi: Xi'an University of Electronic Science and Technology Press

[7] Zhou Hangci. MCU application design techniques [M] Beijing: Beijing University of Aeronautics and Astronautics Press, 2000

- [8] Yu Xicun. SCM principles and interface technology [Z] Shan xi: Xi'an University of Electronic Science and Technology Press .2007.12
- [9] Yu Cchengbo. Sensor and automatic detection technology [Z] Beijing: Higher Education Press, 2009.7:108 to 112
- [10]Cao Hanfang. Digital circuits and logic design basis [Z] Beijing: Electronic Industry Press, 2007.7:119 to 120