

The numerical simulation of the inside flow field of oil – water hydrocyclone with different structures

Bo Liu^{1,2,a}, Juan Xu^{1,2,b} and Yue Wang^{1,2,c}

¹ Shandong Provincial Key Laboratory of Ocean Environment Monitoring Technology, Qingdao 266001, China

² Institute of Oceanographic Instrumentation, Shandong Academy of Sciences, Qingdao 266100, China.

^ahanyu_8224@126.com, ^bxujuan101066@163.com, ^cshinjiwy @163.com

Keywords: Hydrocyclone, the Structure Parameter, Numerical Simulation, Large Eddy Simulation.

Abstract. The large eddy simulation method with mixture model is used to describe the inside two-phase flow of the oil - water separator. Then flow analyses of hydrocyclone field with different structures are compared by numerical simulation in the inside flow field of oil - water hydrocyclone. The result shows that the radial velocity along the column diameter increases from the wall to the axis and it reaches the maximum in a radial location. Then it decreases sharply. The axial pressure difference is the driving force, which makes heavy phase fluid water flow from the wall to the tail pipe outlet, while radial axial pressure difference makes light phase fluid oil accumulate in the center of the vortex tube. The axial pressure difference is the driving force, which makes heavy phase fluid water flow from the wall to the tail pipe outlet, while radial axial pressure difference makes light phase fluid oil accumulate in the center of the vortex tube. Therefore, flow field performance with double conical structure is better than that with the tube structure.

1. Introduction

Cyclone is an efficient separation device, with simple structure, high separation efficiency, flexible operation and many other advantages. And it is widely used in coal, petroleum, chemical industry, food industry, waste water treatment, etc. With the wide application of computers and the increasing storage capacity, the simulation has good accuracy and reliability. In recent years, it is possible to simulate the internals of separation equipment, transportation equipment and reaction equipment. And the calculated results agree well with the test results [1-5]. In this paper numerical simulation method is used to analyze the flow of the internal flow field in the hydrocyclone with double conical structure. And the results provides the basis for further study of separation efficiency and the changing rule of the energy consumption in the process of oil-water separation hydrocyclone.

2. Fluid Model

Large eddy simulation control equation is the averaged equation after filtering the N-S equation.

$$\frac{\partial \bar{u}_i}{\partial t} + \frac{\partial}{\partial x_j} (\overline{u_i u_j}) = -\frac{1}{\rho} \frac{\partial \bar{p}}{\partial x_i} + \nu \frac{\partial^2 \bar{u}_i}{\partial x_j^2} + f_i \quad (1)$$

The micro compressible flow field model is used in the continuity equation.

$$\frac{\partial P}{\partial t} + K \frac{\partial \bar{u}_i}{\partial x_i} = 0 \quad (2)$$

In the above equation, horizontal line presents the quantity after filtering. Relation between the filtration rate \bar{u}_i and actual speed u_i in the large eddy model is $u = \bar{u}_i + u'_i$. K is the square of fluid elastic wave velocity. Nonlinear term exists in the momentum equation. $\overline{u_i u_j} = \overline{u_i u_j} + \overline{u'_i u'_j} + \overline{u_i u'_j} + \overline{u'_i u_j}$. The first item is large scale component and the other three items are small scale components, that is

sub-grid reynolds stress. Then it can be expressed as $\overline{u_i u_j} = \overline{u_i u_j} + R_{ij}$. R_{ij} is the new unknown after filtering, so sub-grid reynolds stress model is established. Then box-filter function is used and the equation (1) can be expressed as follows.

$$\frac{\partial \overline{u_i}}{\partial t} + \frac{\partial}{\partial x_j} (\overline{u_i u_j}) = -\frac{1}{\rho} \frac{\partial \overline{p}}{\partial x_i} + \nu_t \frac{\partial^2 \overline{u_i}}{\partial x_j^2} - \frac{\partial \tau_{ij}}{\partial x_j} + f_i \quad (3)$$

According to the average concept of the turbulence energy generated and dissipation, Smagorinsky assumes $\nu_t = (C_s \Delta)^2 (2\overline{S_{ij} S_{ij}})^{1/2}$ and $\overline{S_{ij}} = \frac{1}{2} \left[\frac{\partial \overline{u_i}}{\partial x_j} + \frac{\partial \overline{u_j}}{\partial x_i} \right]$. Δ is filter width, generally it is grid spacing and $\Delta = (\Delta_x \Delta_y \Delta_z)^{1/3}$. C_s is not only the model coefficient but also empirical constant. When it is taken as 0.1 the result consistent with the experiment can be obtained. So in this paper C_s is 0.1.

The two-phase flow process in the oil-water separator is described by mixture model, which can simulate the multi-phase flow with different velocities. Assuming local equilibrium in the spatial scale, continuity equation of the mixture model is as follows:

$$\frac{\partial}{\partial t} (\rho_m) + \nabla \cdot (\rho_m \bar{v}_m) = 0 \quad (4)$$

The momentum equation of the mixture can be obtained by the sum of momentum equation of all phases, which can be described as follows:

$$\frac{\partial}{\partial t} (\rho_m \bar{v}_m) + \nabla \cdot (\rho_m \bar{v}_m \bar{v}_m) = -\nabla p + \nabla \cdot [\mu_m (\nabla \bar{v}_m + \nabla \bar{v}_m^T)] + \rho_m \bar{g}_m + \bar{F} + \nabla \cdot \left(\sum_{k=1}^n a_k \rho_k \bar{v}_{dr,k} \bar{v}_{dr,k} \right) \quad (5)$$

ρ_m is the mixture density, \bar{v}_m is the average velocity of the mass, μ_m is the mixed viscosity coefficient, \bar{F} is the body force, n is number of phases, a_k is k phase volume fraction, ρ_k is k phase density and $\bar{v}_{dr,k}$ is k phase flowing speed.

The slip velocity \bar{v}_{qp} is defined as the velocity of the second phase p relative to principal phase q. And \bar{v}_{qp} is as follows:

$$\bar{v}_{qp} = \bar{v}_p - \bar{v}_q \quad (6)$$

The relation of flowing speed and slip velocity is as follows:

$$\bar{v}_{dr,k} = \bar{v}_{qp} - \sum_{k=1}^n \frac{a_k \rho_k}{\rho_m} \bar{v}_{qk} \quad (7)$$

The volume fraction equation of the second phase can be got from the continuity equation.

$$\frac{\partial}{\partial t} (a_p \rho_p) + \nabla \cdot (a_p \rho_p \bar{v}_m) = -\nabla \cdot (a_p \rho_p \bar{v}_{dr,p}) \quad (8)$$

3. The calculation model and boundary conditions

The calculation model is shown in Fig.1. The mainly difference of the two hydrocyclones is the bottom. Double conical structure is used in Fig (a) and the tube structure is used in Fig (b). The diameter of whirl cavity is 2D, the length is 2D, inlet diameter is 0.35D and the taper is 2.5° .

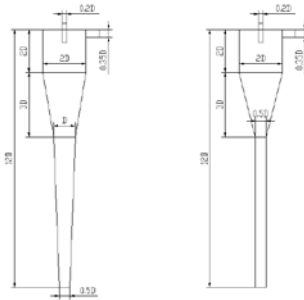

(a) Double conical structure (b) The tube structure

Fig.1 Structure diagram of the hydrocyclone

The equation is discrete by the finite volume method and SIMPLE algorithm is used for the pressure-velocity coupling. The wall is not leaking with non slip condition. Shear, turbulent kinetic energy and turbulent diffusivity are calculated by wall function. The unstructured grid is used to mesh the calculation area. The inlet is taken as the inlet flow quantity. The oil phase is 5%, the density of water is 998.2kg/m³ and the density of oil is 850kg/m³.

4. The discussion and analysis

The flow field distributions corresponding to the two different structures are shown in Fig.2. It can be seen that obvious vortex flow is formed in double conical structure, while core vortices in the tube structure is not obvious.

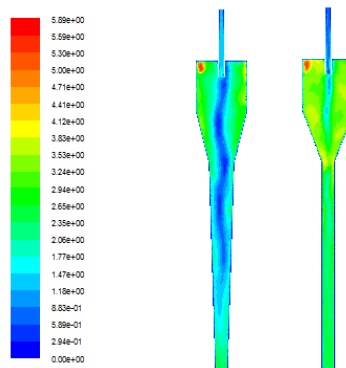

Fig 2 The flow field distribution

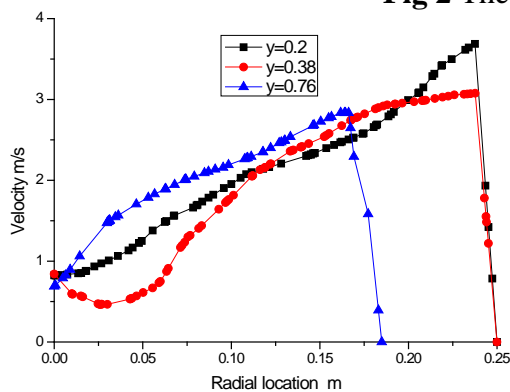

Fig.3 The velocity distribution in double conical structure

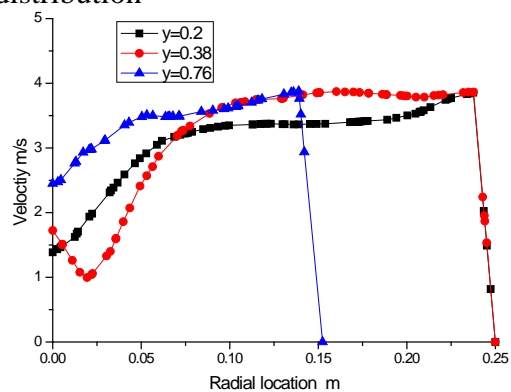

Fig.4 The velocity distribution in tube structure

The velocity distributions corresponding to the two different structures are shown in Fig.3 and Fig.4. It can be seen that tangential velocity along the column diameter increases from the wall to the axis and it reaches the maximum in a radial location. Then the tangential velocity reduces and there is a sharp decrease near the center axis. The axial velocity along the column diameter decreases from the wall to the axis and the direction is downward. Then the axial velocity increases gradually and the direction is upward. And the axial velocity is zero at somewhere in the middle of the hydrocyclone,

which forms the zero vertical velocity locus. The radial velocity along the column diameter increases from the wall to the axis and it reaches the maximum in a radial location. Then it decreases sharply.

Pressure distributions with different structures are shown in Fig.5 and Fig.6. It can be seen that the axial pressure difference is the driving force, which makes heavy phase fluid water flow from the wall to the tail pipe outlet, while radial axial pressure difference makes light phase fluid oil accumulate in the center of the vortex tube. Then the light phase fluid moves to the overflow by the axial pressure difference between the tube and the top overflow, and it finally overflows the tube.

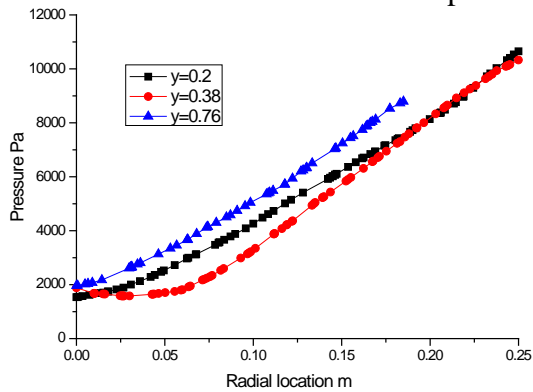

Fig.5 Pressure distribution in double conical structure

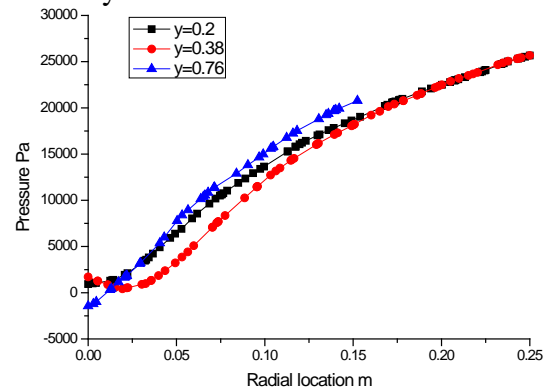

Fig.6 Pressure distribution in tube structure

5. Conclusions

The large eddy simulation method with mixture model is used to describe the inside two-phase flow of the oil - water separator. Then flow analyses of hydrocyclone field with different structures are compared by numerical simulation in the inside flow field of oil - water hydrocyclone. The result shows that the radial velocity along the column diameter increases from the wall to the axis and it reaches the maximum in a radial location. Then it decreases sharply. The axial pressure difference is the driving force, which makes heavy phase fluid water flow from the wall to the tail pipe outlet, while radial axial pressure difference makes light phase fluid oil accumulate in the center of the vortex tube. The axial pressure difference is the driving force, which makes heavy phase fluid water flow from the wall to the tail pipe outlet, while radial axial pressure difference makes light phase fluid oil accumulate in the center of the vortex tube. Therefore, flow field performance with double conical structure is better than that with the tube structure.

Acknowledgements

This work was financially supported by the Youth Foundation of Shandong Academy of Sciences (Project No. 2014QN033).

References

- [1]. Cullivan J. C., et al., New understanding of a hydrocyclone flow field and separation mechanism from computational fluid dynamics, *Minerals Engineering* Vol. 17(2004): p. 651–660.
- [2]. Cokljat, D., Ivanov, V. A., et al., Multiphase k-epsilon Models for Unstructured Meshes, ASME Fluids Engineering Division Summer Meeting, Boston, USA, 2000.
- [3]. Slack, M., Cokljat, D. and Vasquez, S. A., Reynolds-Stress Model for Eulerian Multiphase, *Proc 4th Int. Symp on Turbulence Heat and Mass Transfer*, pp. 1047-1054. Begell House Inc., 2003.