

Flipbook Automatic Electrical Control System Design

Qixing Liu

Guizhou University School of electrical engineering, automation

ZXR67811@163.com, zip code: 550025

Keywords: Automatic machine open book; Electrical control; Circuit design; System design.

Abstract. By flipbook automatic electrical control system design, to understand the structure of the automatic machine open book, working principle and purpose. Users only need to use three buttons control can be achieved, so that the electrical control system design line is simple, accurate, safe, reliable, reasonable structure, easy maintenance, can quickly flip has practical value and broad application prospects.

Introduction

Now officially entered the market a few automatic machine open book, the most representative is BOOK TIME 5000 automatic machine open book. BOOK TIME 5000 automatic machine open book, is the most representative of a foreign machine open book. This automatic machine open book size and 21-inch TV is similar for most of the specifications book, page control buttons. But also with the automatic mode, flip interval can be adjusted. Price up to \$ 3,000. This flipbook machine is too large, not simple, and the price is too expensive for most people can not accept his price. Check out existing domestic and international automatic means open book and found some mechanical manipulation is achieved by open book function, either through electromechanical control to achieve, but the control circuit is more complex. So if we can design a structure in the prior art on the basis of simple and compact, automatic control circuit is simple, easy to carry collapsible, low-cost open book machine, certainly have a good market prospect.[1]

Electrical Control Circuit Design

Motor Selection. Motor as a power source mechanism, affecting the normal operation and efficiency of institutions. In this design, since the terminal force object pages, and each member executive body of plastic material, size is also small, the quality is very light, power is not required, the other institutions velocity is not too large, should control the output speed in 5r / min or so. So I chose Changzhou Haisheng Electric Co 60KTYZ series of miniature AC synchronous geared motor.

Table 1 60KTYZ series AC synchronous geared motors technical parameters

Electric motor model	input power (W)	Synchronous speed (r/min)	Output torque (Kg.cm)	Rated voltage (V)	Reduction ratio
60KTYZ	3	6	1	24	1:85.25

Electrical Control Circuit Design. Electrical control circuit is mainly to control the motor power on and off, start and stop. In this design, there are four motors: left and right side of the paper feed mechanism and the left and right side of the sheet pressure mechanism. Each motor is power-off, starting and stopping, reversing all the electrical control, various travel agencies controlled by the limit switch.[2]

Circuit element table Table:

Table 2 Electrical components Menu

name	effect	name	effect
M1	Left flip motor	M3	Page left pressure motor
M2	Right flip motor	M4	Right sheet pressure motor
HL	Power Indicator	SQ1	The left limit switch reset
SB1	Total power button	SQ2	Page left pressure motor power switch
SB2	Left button flip motor	SQ3	Right sheet pressure motor power switch
SB3	Right Motor flip button	SQ4	Left sheet pressure limit switch
KM1	Left flip motor relay	SQ5	The right of the limit switch reset
KM2	Right flip motor relay	SQ6	Right sheet pressure motor power switch
KM3	Page left pressure motor relay	SQ7	Page left pressure motor power switch
KM4	Right sheet pressure motor relay	SQ8	Right sheet pressure limit switch
QS	Isolating switch	FR	thermal relay
FU	Fuses		

Limit switch layout, as the picture shows:

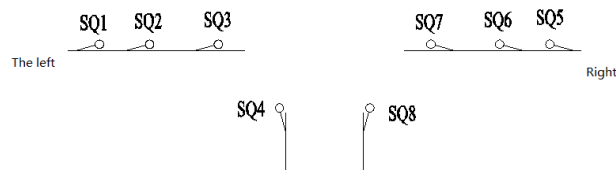

Figure 1. Limit switch layout

Electrical control diagram shown in Figure.

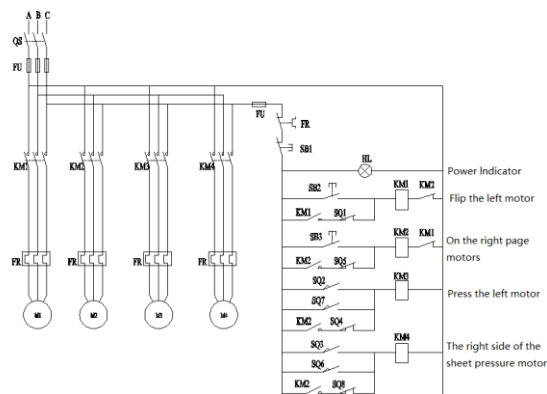

Figure 2. Electrical Control Chart

Electric control principle:

(1) On the left side of the page to start the motor M1 is stopped

Close button SB2, KM1 coil is energized, the normally open main contacts and auxiliary contacts KM1 closed simultaneously, so that the left side of the motor M1 rotate flip, flip crank when the stopper on the hit limit switch SQ1, limit switch normally closed contact point SQ1 off, KM1 coil is energized, the normally open main contacts and auxiliary contacts are open, the motor M1 loss of power, stopped. [3]

To prevent misuse, the left and right page rollover motor control mode using the Internet, when

one side of the motor power work, the other side of the motor circuit are off, press the button can not even start.[4]

(2)The right of the page to start the motor M2 is stopped

Close button SB3, KM2 coil is energized, the normally open main contacts and auxiliary contact KM2 closed simultaneously, so that the left side of the motor M2 rotate flip, flip crank when the stopper on the hit limit switch SQ5, limit switch normally closed contact point SQ5 off, KM2 coil is energized, the normally open main contacts and auxiliary contacts are open, the motor M2 loss of power, stopped.[5]

(3)The left pressure motor M3 start, stop

When the left side of the page to start the motor rotates, the slider crank mechanism driven movement. Crank rotation after a certain angle, the stopper crank on the impact limit switch SQ2, limit switch SQ2 normally open contact closure, KM3 coil is energized, the normally open main contacts and auxiliary contacts KM3 closed simultaneously, so that the left side of the sheet pressure motor M3 is rotated when the crank stopper sheet pressure on the impact SQ4 limit switch, limit switch normally closed contact SQ4 disconnect KM3 coil is energized, the normally open main contacts and auxiliary contacts are open, the motor M3 loss of power, stopped rotation.

When the right side of the page to start the motor rotates, the slider crank mechanism driven movement. Crank rotation after a certain angle, the stopper crank impact on travel switch SQ7, limit switch normally open contact SQ7 closed, KM3 coil is energized, the normally open main contacts and auxiliary contacts KM3 closed simultaneously, so that the left side of the sheet pressure motor M3 is rotated when the crank stopper sheet pressure on the impact SQ4 limit switch, limit switch normally closed contact SQ4 disconnect KM3 coil is energized, the normally open main contacts and auxiliary contacts are open, the motor M3 loss of power, stopped rotation.[6]

(4)The right of the press motor M4 start, stop

When the left side of the page to start the motor rotates, the slider crank mechanism driven movement. Crank rotation after a certain angle, the stopper crank limit switch SQ3 impact, limit switch SQ3 normally open contact closure, KM4 coil is energized, the normally open main contacts and auxiliary contacts KM4 closed simultaneously, so that the right side of the sheet pressure motor M4 is rotated when the crank stopper sheet pressure on the impact SQ8 limit switch, limit switch normally closed contact SQ8 off, coil KM4 energized, normally open main contacts and auxiliary contacts are open, the motor M4 loss of power, stopped rotation.[7]

When the right side of the page to start the motor rotates, the slider crank mechanism driven movement. Crank rotation after a certain angle, the stopper crank impact on travel switch SQ6, limit switch normally open contact SQ6 closed, KM4 coil is energized, the normally open main contacts and auxiliary contacts KM4 closed simultaneously, so that the right side of the sheet pressure motor M4 is rotated when the crank stopper sheet pressure on the impact SQ8 limit switch, limit switch normally closed contact SQ8 off, coil KM4 energized, normally open main contacts and auxiliary contacts are open, the motor M4 loss of power, stopped rotation.[8]

The Power Supply Design

Plug-in Works. In this design, select the 24V DC micro gear motor as a power source. When plugged in to work, simply open book's power charger into the hole to power work. Referring now powered chargers and related reader holes on the market designed and powered charger hole of the open book machine. Left and right side of the page turning motor power cable is connected and powered via a push button switch hole, press the left and right side of the page electrical power line through the limit switch is connected with the conductive hole. Wiring diagram shown in Figure.[9]

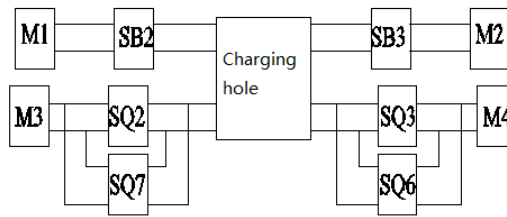

Figure 3. Electrical wiring diagram is inserted

Battery-Powered. In the back of the machine is equipped with a battery compartment open book, simply indicate the batteries with the positive and negative into, you can plug in place of work. Motor and battery wiring and plug work the same way. [10]

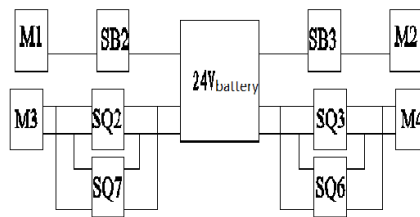

Figure 4. Battery wiring diagram

Conclusion

The machine is designed to automatically open book portable, cheap as a design goal, use a simple mechanism and control the manner this open book machine design and implement low-cost and portable features, to meet the basic functions of the machine open book, but also with automatic control circuit controls, can quickly turn the page, you can either use unplugged mode, it can also work with a battery power supply.

References

- [1] Zhengfu Zhang: *Application of programmable logic controller (PLC) in electrical control* [J], Inner Mongolia Petrochemical Industry, Vol. 10 (2012)
- [2] Macai Feng: *Research on the reliability of PLC automatic control system and its design scheme* [J], Association for science and Technology Forum (second half), Vol. 11 (2011)
- [3] Zhenlong Yao: *Analysis on the application and development of PLC in electric automation* [J], Science and Technology Innovation Herald, Vol. 26 (2011)
- [4] Ziwen Xu: *Research on the application of PLC in electric automation* [J], Science and technology wind, Vol. 06 (2011)
- [5] Jianzhong Fan, Aiqin Liu, Yanwei Wu: *Application status and development prospect of PLC in electric automation* [J], Science and technology information, Vol. 32 (2009)
- [6] Haixia Li, Weilin Zhang: *Integrated application technology of electrical control and PLC* (People's Posts and Telecommunications Press, China 2015)
- [7] Rongrong Yao: *Electrical control technology* (China Electric Power Press, China 2014)
- [8] Kewan Jiang: *Electrical control and PLC project course* (Dalian University of Technology Press, China 2014)
- [9] Chongyi Mai: *Electrical control technology and skills training* (Electronic Industry Publishing House, China 2010)

[10]Lijun Liu: *Electrical control and power saving system design* (China Electric Power Press, China 2013)