

# Research on the Urban Garbage Collection System Based on Multi Sensors

Yan Li, Yulei Huang

ZTE Telecommunication College, Xi'an Peihua University, 710125, Xi'an, China

79132181@qq.com

**Keywords:** garbage system; RF wireless network; sensor introduction

**Abstract.** Aiming at the current situation of urban living garbage information degree is not high, and combining with the present social hot issues, put forward a kind of city garbage collection system based on RF wireless networks, including the system functional description, hardware design, software design. achieving a long distance and fixed point, real-time monitoring. Improving transport in the process of garbage collection is high, time consuming, implementation the tracking and monitoring of garbage from the source to the disposal of terminal in the whole process.

## 1 Introduction

With the development of social economy, people's demands for living environment are increasing. Living standard is getting higher and higher, however, waste production also increasing. Therefore, problems of urban garbage collection and processing are becoming more seriously. The needs for long distance, fixed-point, real time monitoring rubbish are urgent, so the establishment of city garbage collection system has practical significance.

The AT89C52 microcontroller as controller, combined with RF wireless networks and sensor technology was used to build the garbage information collection system in this paper. Through designing both hardware and software of the system, and experimental study on the function of the system, this paper provides an important guarantee on the subsequent product realization system.

## 2 System Design

The paper designed a novel garbage, equipped with a variety of sensors, such as, pyroelectric infrared sensor, sound sensor etc. Through the sensor feedback signal collecting rubbish information, Si4432 wireless RF module will collect the garbage information and sent it to the transit station main control MCU system. Transfer station uses GSM communication network technology to send the status of rubbish to garbage transport vehicles, which will enable the garbage trucks receiving real-time information processing. Garbage information can also be displayed through the 12864 LCD screen and buzzer. The GSM network is used to exchange the garbage transfer station, the garbage transport vehicle and a set of garbage collection. The flow chart of the overall plan of the system is shown in Figure 1.

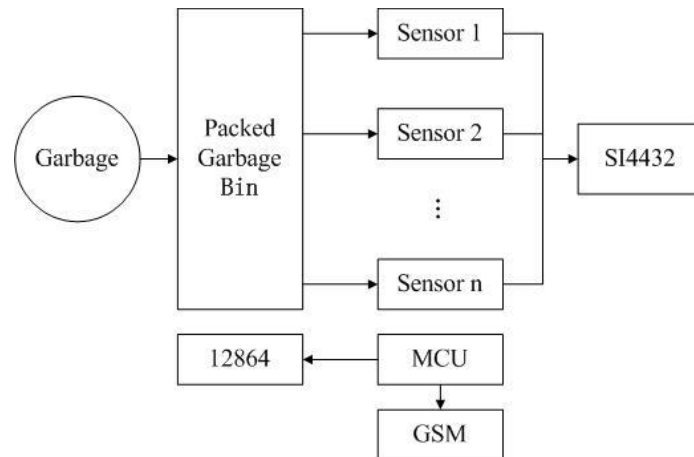

Figure 1. System Overall plan flow chart

### 3 Hardware Design

**3.1 Control Module.** The system employed an AT89C52 microcontroller, which is a kind of 8K bytes of flash programmable with erasure of read-only memory low voltage and a high-performance comos8 microprocessor. The display was controlled through the terminal connection of main chip LCM12864, the P0 (P0.0~P.7), P3.6 and P3.7 port, which is also connected the NAND gate 74hc chip and LCM E. The main control circuit diagram is shown in Figure 2.

The main parameters of STC89C52 are as follows:

*Main power pin (2)*

*VCC (Pin40): the power input connection, + 5V power supply*

*GND (Pin20): ground wire*

*The external crystal pin (2)*

*XTAL1 (Pin18): the input of the on-chip oscillator circuit*

*XTAL2 (Pin19): the output of the on-chip oscillation circuit*

*Control pin (4)*

*RST/VPT (Pin9): reset pin, pin on the 2 machine cycle of the high level will enable the MCU reset.*

*ALE/PROE (Pin30): address latch enable signal*

*PSEN (Pin29): external memory read strobe signal*

*EA/VPP (Pin31): the internal and external program memory, the low level from the external program memory read instructions, if the high level from the internal program memory read instructions.*

*The programmable input / output pin (32)*

*STC89C52 microcontroller has 8 groups of 4 programmable I/O port, respectively, bit P0, P1, P2, P3 port, each port has 8 (8 pin), a total of 32.*

*P0 mouth Pin39 ~ Pin32: 8-bit bidirectional I/O lines, the name for p0.0 - p0.7 P1 mouth (Pin1 to pin8): 8-bit bidirectional I/O lines name P1.0 ~ P1.7 P2 Pin21 ~ Pin28: 8-bit bidirectional I/O lines, the name for p2.0 to p2.7, P3 mouth Pin10 ~ the pin17: 8-bit bidirectional I/O lines, the name for P3.0 ~ P3.7.*

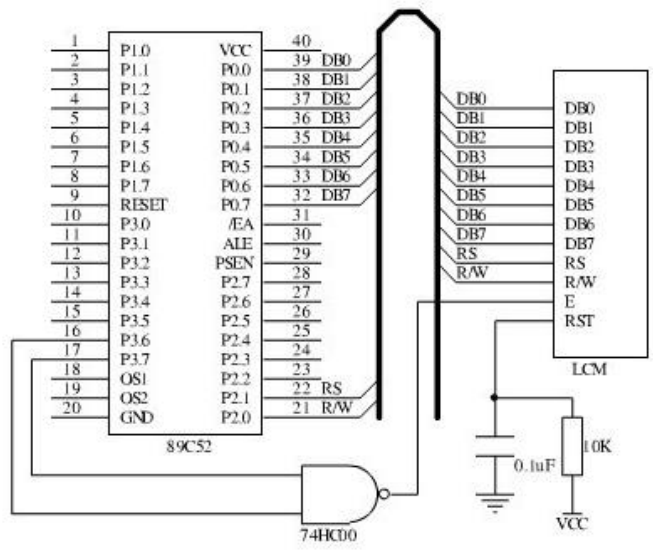

Figure 2. Main control circuit diagram

**3.2 Radio Frequency Wireless Module.** SI4432 is a high degree of integration, low power and multiband ezradioprowireless transceiver chip from Silicon Labs. The voltage is between 1.9~3.6V and it has 20 pin QFN package (4mm×4mm). It can work for 4 bands including 315/433/868/915 MHz. It is equipped with internal integration diversity antenna, power amplifier, wake up timer, digital modem, 64 bytes of transmit and FIFO data, and configurable GPIO. SI4432 when in use, the required external components rarely, a 30 MHz crystal oscillator, a couple of capacitance and inductance can be composed of a system of sending and receiving of high reliability, simple design, and low cost.

SI4432 receiver sensitivity to -117dB can provide excellent quality of the link, in expanding the transmission range and minimizing power consumption; minimum filter bandwidth of up to 8 kHz, with an excellent channel selectivity; in the 240~960MHz band and power amplifier for maximum work output rate can reach + 20dbm, well-designed receive the farthest distance up to 2km. Therefore, the system uses SI4432 wireless transceiver module, and its pin diagram is figure3.

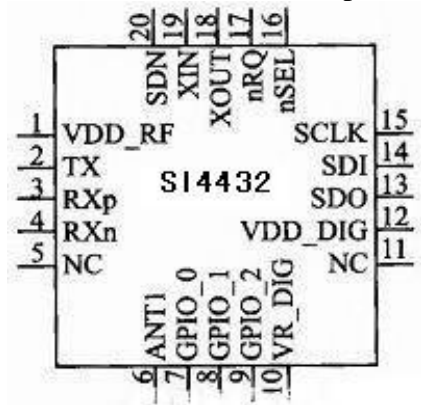

Figure 3. Pin diagram

**3.3 Pyroelectric Infrared Sensor.** Pyroelectric infrared sensor is in size of 2×1mm, composed of high coefficient of thermoelectric materials, such as lead titanate, lithium, tantalum, sulfuric acid and so on. One or two detecting elements are arranged in each detector, and two detecting elements are connected in reverse polarity to suppress the interference caused by the rising of the temperature of the self. The infrared radiation is detected and received by the detecting element, which is changed into a weak voltage signal. The field effect tube installed in the probe is amplified and output is outward.

The infrared center wavelength of the human body radiation is 9~10 μm, and the wavelength sensitivity of the detector is stable in the range of 0.2~20 μm. Sensor is set at the top end is provided with a filter glass window, the filter can let the 7 to 10 μm wavelength light go through. It is perfect

for in the exploration of the infrared radiation of human body, and the other wavelengths of infrared filter can be absorbed.

In this paper, the RE200B type pyroelectric infrared sensor see Figure 4 is installed on the wall of the garbage can shown in Figure 5. The main parameters are as follows:

working voltage: DC6~24V.

Operating wavelength: usually 7.5~14  $\mu$ m.

Level output: 3V someone, 0V no one

Induction angle: the maximum level of 140 degrees, the maximum vertical 60 degrees.

Static current: less than 50  $\mu$ A.

Induction distance: 0.5~7m.

Trigger time: about 5~10s.

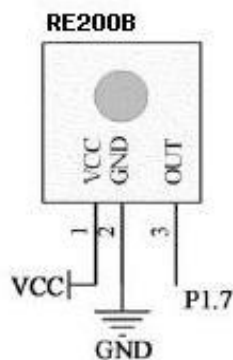

Figure 4. RE200B Schematic Diagram

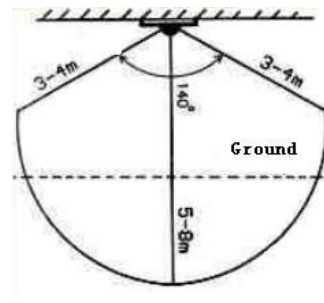

Figure 5. RE200B Erection diagram

**3.4 Sound Sensor.** Sound sensor using LM386 module, to enlarge the various audio processing, its working principle: sensor built-in high-sensitivity capacitive electret microphone, sound waves to the microphone electret film vibration, cause the capacitance changes, generated with the corresponding changes of the tiny voltage. The voltage is then converted into a voltage of 0~5V DC, after the A/D conversion is accepted by the data collector, and transmitted to the MCU.

**3.5 The Weighing Sensor.** Considering the load and equipment easy to install and MTBF, the cantilever beam strain gauge is used as the sensor, which is distributed in the bottom of the trash. Select model for YZC-1B weighing sensor, its parameters are as follows:

*Quantity:* 4.

*Sensitivity:*  $2 + 0.002mV/V$ .

*Recommended excitation voltage:* 10 ~ 12VDC.

*Maximum excitation voltage:* 15VDC.

*Range:* 20kg.

*Material:* alloy steel material, inner sealing glue, oil proof, waterproof, corrosion resistance.

S type beam structure design, pull and press two-way bearing, convenient and flexible installation and use.

After the installation of the sensor, the sensor of zero calibration and set up garbage weight limit value. At the same time, in the control, use the chip icl7107 weighing signal processing, then the signal is sent to the MCU complete the trash weighing function. If the weight of the garbage can exceed the upper limit, it will alert the garbage to be overweight.

**3.6 Smoke Sensor.** In the trash, if the smoke concentration exceeds the preset value, or high temperature ignition other waste fire, garbage box smoke sensor will detected. At the same time, the situation in the form of text messages to the transfer station through the wireless communication module. So, that prevents unnecessary losses.

Smoke sensor select smoke sensor MQ-2, it can detect liquefied gas, methane, propane, methane, alcohol, hydrogen, smoke and so on, the size of sensitive can adjust. When the MQ-2 detect flammable and explosive gas or smoke, it will produce a low level transmit to the SCM. After SCM detect of the low level, SI4432 wireless data transmit the number to the SCM and the buzzer alarm.

After receiving the signal of the garbage box number, the remote buzzer alarm digital tube displays the number of the garbage bin to determine the location of the alarm garbage bin.

**3.7 Height Monitoring Sensor.** Infrared sensor and a reflection type infrared sensor Is a pair of infrared transmitting and receiving tube through the circuit into a switch signal after the finished product. the internal integrated amplifying circuit and a PNP and NPN normally open normally closed output or voltage pull-down output. It achieved with a simple circuit to detect the location of the garbage bag and let the lights shine.

In view of the close distance of the trash, the infrared photoelectric sensor based on E3F-5DP1 is selected. The sensor is mounted on the side wall of the garbage barrel and its high sensitivity, fast frequency response, high precision, transient process is short, high power output, dispatches the characteristics of a good, stable and reliable work, long service life. If the two probe of the sensor is blocked by garbage, the circuit is conducted, and the indicator lamp is illuminated. When the garbage is not blocked, often open, the indicator light is not bright.

#### 4 System Software Design

The heat release electric infrared sensor and sound sensor are used to determine the existence of life inside the garbage. If there is, the Si4432 RF module composed of wireless network will send signal to the waste transfer station, then garbage transfer stations will transfer the information through GSM network to working people and vehicles to rescue.

If the heat release electric infrared sensor and sound sensor to detect trash inanimate is trash are automatically compressed, compressed by heat release electric infrared sensor detecting garbage barrel garbage storage, composed by Si4432 wireless network to send to refuse transfer station, garbage transfer station and then interact through GSM network and the transport vehicle, vehicle scheduling transportation to real clean-up has been full of garbage. The system software flow chart is shown in Figure 6.

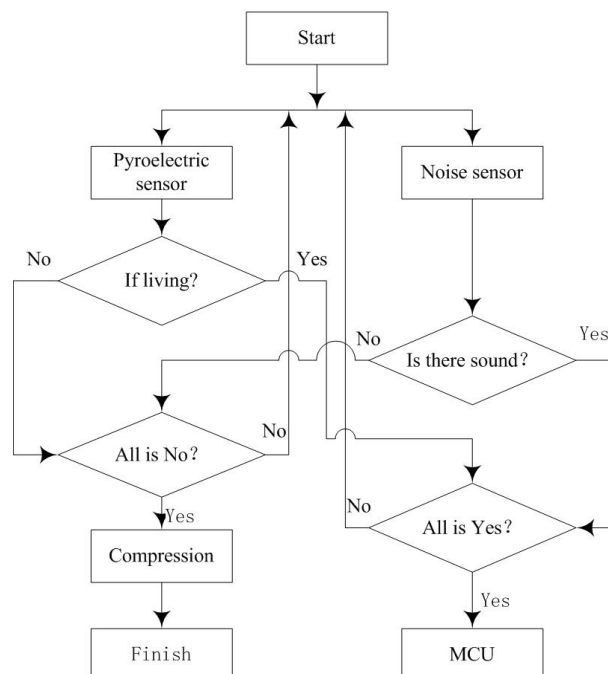

Figure 6. System software flow chart

#### 5 Experiments

A control experiment was adapted in the course of the study and a simple real trash as figure7, the main control circuit box was made as figure8. The control program is written by Keil C51 language. C51 language has good readability, maintainability, easy modularization, and easy to transplant. The control program is written well programmed into the microcontroller, good debugging.



Figure 7. Simple trash photo

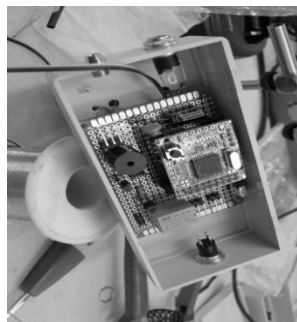

Figure 8. The main control circuit box

## 6 Applications and Promotion

The basic idea of this research is through the study of this issue, given a set of feasible city garbage collection system. Its main content is based on the current problems existing in the garbage collection is analyzed, the solution is given, this paper discusses the basic idea of the topic, solve the environmental pollution and damage caused by the waste accumulation, solved the manpower and material resources; Through the monitoring of the trashcan spam, once has the life information, such as baby can warning saved; Through monitoring of trash can, once found fire problem, the same warning to save, to avoid the fire, to personal safety, property protection.

This topic application prospect is good, with the development of the society, the life of people increasing amount of waste, the problems will be more and more, every year the government invested billions of dollars to deal with the rubbish. For the content of this research, can solve the manpower and material resources to protect the environment, to monitor the quality of the trash can, in case of fire, avoid abandoned, has important practical significance.

## 7 Conclusions

The project has employed sensor technology and wireless network technology to collect urban garbage information-the amount of rubbish, temperature, hazardous materials, etc. There are the three highlights in this paper: city garbage cans are remote, fixed-point, real time monitoring. This study also solves some hot issues of society and has a positive impact on the current construction of the theme of environmental protection clean city, and has improved the living environment and created a beautiful city hyper chromic.

Acknowledgment: This work was supported by the Scientific research project in Shaanxi province department o f education..No.14JK22.

## References

- [1] R.J. Ellison, D.A. Fisher, and R.C. Linger, Survivable Network System: An Emerging Discipline. Technical Report, CMU/SEI-97-TR-013, Carnegie Mellon University,2012.
- [2] R.J. Ellison, D.A. Fisher, and R.C. Linger, Survivability: Protectiong Your Critical Systems, IEEE Internet Computing, vol. 3, issue 6, pp. 55-63,2009.
- [3] Dan, Y.Q. Zhang, Research on Definition of Network Survivability,Journal of Computer Research and Development, vol. 43(Suppl.), pp. 525-529, 2006.
- [4] K.Q. Zhao, Set pair analysis and its preliminary applicatio. Hangzhou, Zhejiang Science and Technology Press, 2000.
- [5] K.Q. Zhao, A.L. Xuan, Set Pair Theory - A New Theory Method of Non-Define and Its Applications,” System Engineering, vol. 14, issue 1, pp. 18-23, 1996.
- [6] Y.L. Jiang, C.F. Xu, Advances in Set Pair Analysis Theory and its Applications,Computer Science, vol. 33, issue 1, pp. 205-209, 2006.