

Optimization Design of Printing Nozzle for a Delta 3D Printer

Jun WANG^a, Hong-Jie CHEN, Ya-Jing GONG, Quan WANG and Jun REN

Center for Robotics Research, School of Mechanical Engineering, Hubei University of Technology, China

junwang@mail.hbut.edu.cn

Keywords: Delta 3D printer, The printing nozzle, Temperature field, Ansys Workbench.

Abstract. Delta 3D printer is a kind of 3D printer with parallel structure. It is easy to print and has wide adaptability. However, the complex installation, plugging of print head, surface quality of printed parts and quality of printing head limits the development of its application. This paper analyzes the thermodynamic characteristics of the nozzle by using Ansys Workbench. With simulation results, the printing nozzle and head is redesigned and tested. The results show that the installation of print head is more convenient and the printing quality is improved after optimization.

Introduction

3D Printing, also known as additive manufacturing[1], was born in 1980s. It is a forming technology based on a mathematical mode. It uses layer by layer printing technology to form arbitrary shapes, arbitrary structures and sections[2]. 3D printing prototyping technology gives new vitalities to traditional manufacturing industry. Compared with other powder forming technology or liquid resin molding method, the materials of 3D printers are cleaner and easy to save without pollution. Although 3D printing has been rapid development in decades, the problems of installation process, not enough accuracy, low manufacturing speed, etc. limits its wide application. The appearance of low-price desk 3D printer makes its popular to the common users. This paper aims to improve 3D printing quality by optimize the design of the printing nozzle and head.

Thermodynamic Analysis Principle for the Printing Nozzle

Heat is a common phenomenon in the physical field. In the engineering analysis, there are three ways for heat transfer, i.e., heat conduction, heat convection and heat radiation. Because of the insulating layers outside the 3D print head, heat radiation has little impact for the whole part. This paper ignores the study of heat radiation. Heat convection means the transfer way between the various parts of different temperature because of relative motion. This paper studies the heat conduction between different parts of the nozzle. Heat conduction describes the temperature contrast in the interior of the object. Heat transfer forms high temperature part to low temperature part when the objects with different temperature contact.

Heat condition follows Fourier's Law of Eq.(1),

$$\vec{q} = -\lambda \text{grad}t = -\lambda \nabla t = -\lambda \frac{\partial t}{\partial n} \vec{n} \quad (1)$$

In Eq.(1), \vec{q} means density of heat flow rate. λ is thermal conductivity. t is temperature. n is the normal direction of the temperature distributions. Minus is the temperature flow direction. $\text{Grad} t$ is the temperature gradient, which can be described with Eq.(2).

$$\text{grad}t = \nabla t = \lim_{\Delta n \rightarrow 0} \frac{\Delta t}{\Delta n} \vec{n} \quad (2)$$

The expression of temperature gradient in Cartesian coordinate system is

$$\nabla t = \text{grad}t = \frac{\partial t}{\partial x} \vec{i} + \frac{\partial t}{\partial y} \vec{j} + \frac{\partial t}{\partial z} \vec{k} \quad (3)$$

The component of Fourier's law in Cartesian coordinate system can be written as

$$\begin{aligned} \bar{q}_x &= -\lambda \frac{\partial t}{\partial n} \cos(n, x) = -\lambda \frac{\partial t}{\partial x} \\ \bar{q}_y &= -\lambda \frac{\partial t}{\partial n} \cos(n, y) = -\lambda \frac{\partial t}{\partial y} \\ \bar{q}_z &= -\lambda \frac{\partial t}{\partial n} \cos(n, z) = -\lambda \frac{\partial t}{\partial z} \end{aligned} \quad (4)$$

Simulation Analysis of the Nozzle Assembly

The models of the nozzle assembly is designed with 3D modeling software Solidworks. And then heat conduction is analyzed by Ansys workbench. The main materials of the nozzle assembly includes aluminium alloy, brass, stainless steel[5]. In this paper, PLA material is selected for printing models. The print temperature of this material is between 170 to 230 Celsius degrees. Assumes this material has no pungent smell, no contractility, no pollution and it is suitable to print in public place. Because too high temperature easily makes PLA carbonize and too low temperature makes PLA low fluency, it is set 210 Celsius degrees as thermal resistance temperature and 22 Celsius degrees as boundary ambient temperature. The way of transferring heat is heat conduction between the contact objects. As shown in Figure 1, it is the full cross-sectional for head combination of 3D printer. The combination uses six holes of fisheye suspension platform and U type aluminum block connected by bolts. Then uses fisheye suspension platform and three sets of parallel bars to connect and controls print head to move in three directions of X, Y, Z by three stepper motors. In this way, the head print can translate and move up and down. Figure 2 shows the grid division of the nozzle assembly.

Figure 3 is the temperature distribution image of the nozzle assembly. Figure 4 is the temperature distribution of the Teflon hose. As shown in Fig 4, the PLA material begins to soft when it flows through the K2 point, even to the molten state. According Fig.1 and Fig.4, when the high temperature pipe at the K2 point, it cannot fully contact with the Teflon hose due to the influence of the temperature. And then it may cause molten PLA material to block the Teflon hose until the print head is completely blocked. Besides, the channel length as directly affects the speed of molten material in the pipe. The resistance caused by molten material is difficult to avoid. In order to avoid the block of print head caused by insufficient driving force, this paper chooses to shorten the distance of the runner to improve the speed of the molten material. So in the design of print nozzle, it lets the material begin to melt when it enters the heating block.

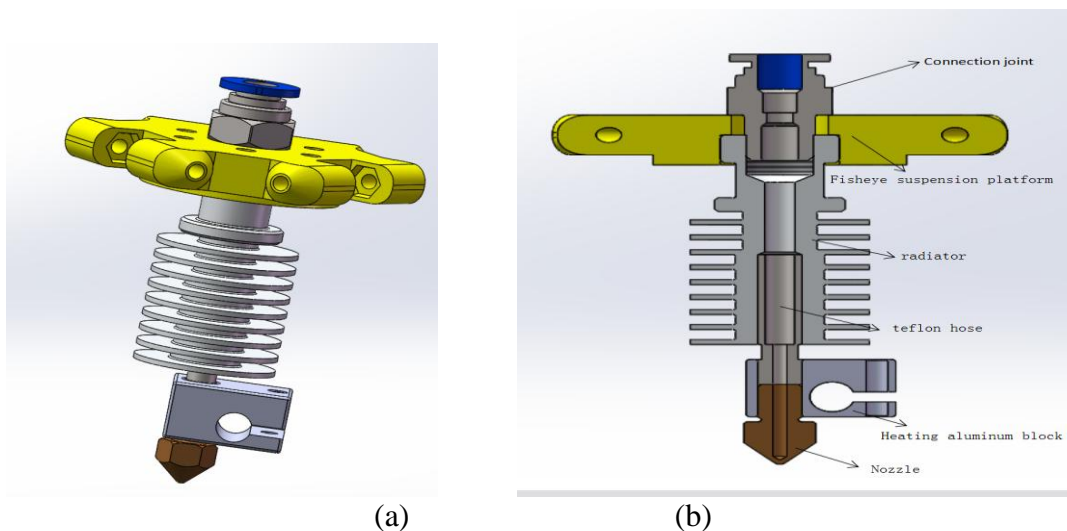

Figure 1. Nozzle assembly model

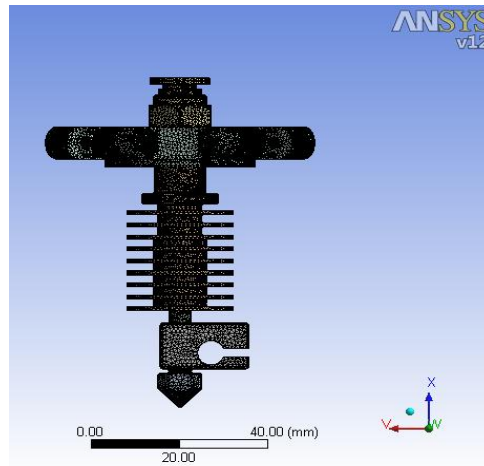

Figure 2. Grid division of nozzle assembly.

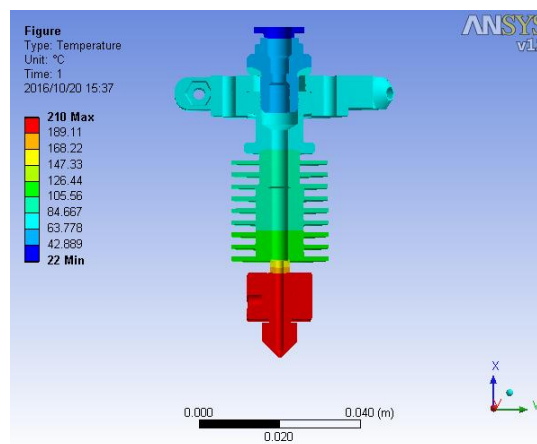

Figure 3. The temperature distribution of nozzle assembly.

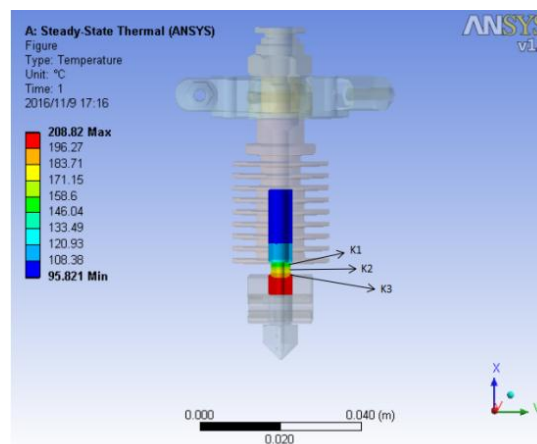

Figure 4. The temperature distribution of Teflon hose.

Optimization Design of Nozzle Assembly

Structure Optimization of Teflon Hose

According to the simulation analysis and practical work, when the motor running speed and the melting speed can not be perfectly matched, K1 point is likely to plug. On the other hand, due to the area of K1 point dropped sharply, it may also cause the blocking situation. Therefore, it increases the area of K1 point plane as shown in Figure 5.

Structure Optimization of Radiator

As shown in Figure 1, the inner hole diameter of the combination of the radiator and Teflon hose is 6mm. The high temperature pipe inserted into it may cause the problems of great resistance and installation process trouble. And in the case of the occurrence of blocking, the whole of the high temperature hose must be pulled out. Sometimes it needs to tear down the entire nozzle assembly. In the process of loading and unloading, it causes the great inconvenience, increases the mechanical errors and reduces the accuracy of the printing. As shown in Figure 5, reducing the diameter of the upper end of the radiator to 2mm can fix the high temperature pipe in the radiator. It helps to increase the convenience of disassembly and assembly. And it helps to find plugging point and improves work efficiency in the case of plugging.

Structure Design of Printing Joint

The print head assembly needs fish-eye suspension platform to connect. However, because the print head is fixedly connected by the bolts in the narrow space, it greatly increased the difficulty to install and reduced work efficiency. In Figure 5, the printing joint and fish-eye suspension platform is interlocking by nut slice, forming a central location. By using this technology, the installation process is more convenient, more accurate in location and easy to load and unload.

Thermal Analysis of Print Head Assembly

After remodeling, the high temperature resistant tube is inserted into the radiator. As shown in Figure 5, it selected Teflon as the material of high temperature tube. The thermal conductivity is $0.21\text{W}/(\text{m}^\circ\text{C})$. After thermal analysis of the model, as shown in Figure 6, it is the temperature distribution of nozzle assembly after optimization. And Figure 7 shows the temperature distribution of high temperature resistant pipe.

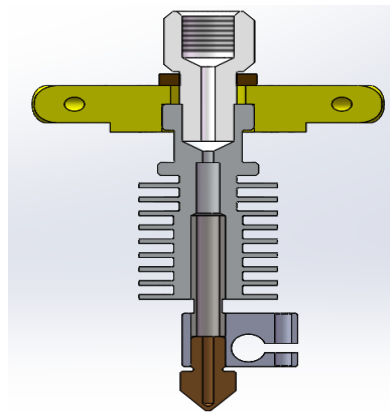

Figure 5. Section view of nozzle assembly after optimization.

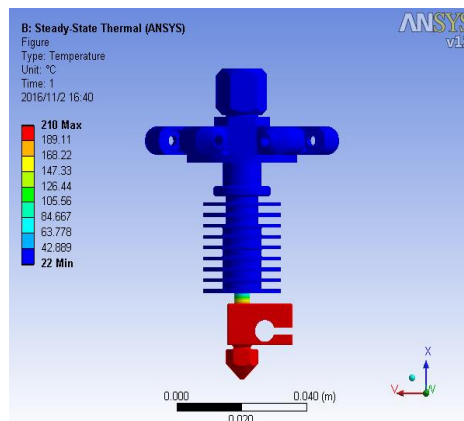

Figure 6. The temperature distribution of nozzle assembly after optimization.

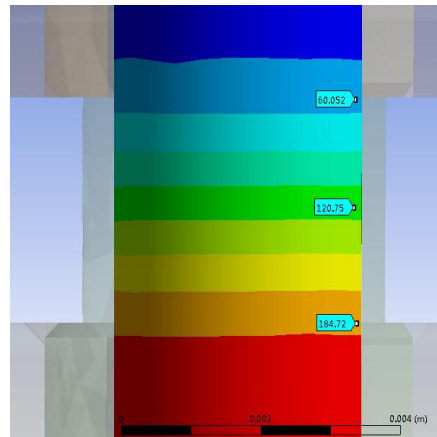

Figure 7. The temperature distribution of high temperature resistant pipe.

As shown in Table 1, the temperature of the print head assembly significantly reduces above K2 point. However, there is no obvious change at K3 point. This shows when the wire extrusion is closing to the K3 point, the PLA materials begin to melt. It shows that when PLA materials is into the heating aluminum block, the materials start to melt. It helps to reduce the possibility of plugging of print head, reduce the friction resistance of materials in the process of extruding, shorten the distance of materials running in the hose, increase the driving force of high temperature and then increase the smoothness of materials in the process of extruding.

Table 1. Temperature distribution before and after optimization.

Temperature(°C)	Heat sink	Teflon hose	K1	K2	K3
Before optimization	71.622	95.821	134.9	167.04	186.98
	114.95	208.82			
After optimization	22.204	65.005	60.052	120.75	184.72
	36.54	207.38			

Results

(1) This paper uses the method of fixing the printing joint and nut slice to quickly formed the central positioning. It helps to save the materials and improve the work efficiency.

(2) The 2mm hole of the radiator effectively helps to stuck the high temperature pipes. It avoids the inconvenience of loading and unloading due to block. And it reduces mechanical errors.

(3) This paper uses the structural optimization of the print head to effectively reduce the temperature of the radiator and the print head, to increase the driving force, to increase the smoothness of silk in the print head. It helps to solve the block problem of 3D print head and provides an additional way for the development of 3D printing technology.

Acknowledgements

This work was supported by the Key project of Natural Science Foundation of Science and Technology Department of Hubei Province under Grant No. 2015CFA112, the Outstanding Youth Science and Technology Innovation Team Program of HuBei Provincial Department of Education under Grant No.T201505, and the National Natural Science Foundation of China under Grant No.51405140.

References

1. Z.L. Yuan, H. Fang, J.G. Huang, W.J. Zhang, Z.H. Xie, *Manufacturing Technology and Machine Tool* **4**, 21(2016)

2. B. Wittbrodt, A.G. Glover, J. Laureto, G.C. Anzalone, D. Oppliger, J. Llrwin, J.M. Pearce, *Mechatronics***23**, 713(2013)
3. N. Baroiu, *Industrial Design and Engineering Graphics***7**, 29(2016)
4. B.H. Lu, D.C. Li, *Machine Building and Automation***42**, 1(2013)
5. L. Wang, J. Liu, *Science China(Technological Sciences)***9**, 1721(2014)
6. X.L. Li, J.X. Ma, P. Li, Q. Chen, W.M. Zhou, *Process Automatic Instrumentation***35**, 1(2014)
7. L. Xiao, X.M Ma, Y.Y. Ma, Z,Y. Xie, *Machinery***7**, 15(2014)
8. L. Wang, Z.L. Li, J. Wang, D.J. Qi, D.F. Yang. *Machinery and Electronics***34**, 27(2016)
9. P. Mcguiinness, W. Drenckhan, D.Weaire, *Journal of Physics D Applied Physics***38**, 3382(2005)
10. X. Wang, M. Damodaran, *Journal of Propulsion and Power***18**, 217(2015)