

# Modeling of Serial Port Communication in the Three-axis Turntable Simulation System

Hongmei Zhang<sup>a</sup>, Changzhen Liu<sup>b, \*</sup> and Gungyan Xu<sup>c</sup>

School of Automation, Shenyang Aerospace University, Shenyang, 110136, China

<sup>a</sup>Zhang.hongmei@163.com, <sup>b</sup>1135423666@qq.com, <sup>c</sup>guangyan-Xu@163.com

**Keywords:** RS-422, Serial port communication, S - Function, Turntable simulation system.

**Abstract.** For the research of a certain unmanned aerial vehicle's inertial navigation system and flight control system, a simulation system of the three-axis turntable is designed. This system adopts host computer and turntable control computer. S-Function with C++ language is used in the host computer to establish the serial communication interface model. Fast data communication between the two computers is achieved by the RS-422 serial port. The test shows that the system has the characteristics of high precision, real-time and reliable operation. This system can be extended to hardware-in-the-loop simulation experiment.

## 1. Introduction

In the ground flight simulation, the three-axis turntable simulation system can simulate attitudes of the aircraft under the laboratory conditions and reproduce its dynamic characteristics availablely [1]. Which can verify the design of flight control system is reasonable, find the design defects of flight control system, and make necessary adjustments.

The communication established between the host computer and the turntable control computer is one of the key technologies of the three axis turntable to accurately simulate the flight attitude. In the hardware-in-the-loop simulation (HILS) of UAV, the Simulink module is used to create the digital aircraft model on the simulation computer generally. Compared with other means of communication, serial communication is easy to connect and it doesn't require the support from operating system [2].

Paper [3] proposes S-Function can be used to realize the real-time control of the various types interface in RTW/xPC target. Scholar Xie Daocheng [4] realizes the transmission of acceleration information and the communication between the missile borne computer and the inertial measurement unit IMU7200 with RS-232 serial port. The RS - 422 serial communication modeling problem is solved based on dSPACE DS4201s RTI library module, S-Function and Stateflow in paper [5, 6], creating the model of the serial communication interface between the simulated satellite computer and the on board computer.

In this paper, the communication protocol between host computer and turntable control computer communication is based on the underlying hardware. The protocol requires the turntable control computer to receive the control instructions from the host computer and return the real-time position information of the three axes to the host computer at the same time. The standard RS-232 serial communication module in Simulink operation mode is half-duplex, it can't reach the requirements of the full duplex operation mode in the communication protocol. Compared with the RS-232 serial communication, RS-422 serial communication has longer transmission distance, higher baud rate. For the task implementation and transmission speed, standard communication module in Simulink cannot complete the demands of the communication.

In this research, based on the S-Function, the serial communication model is established, which solves the problem of high-speed communication between the host computer and the turntable control computer. This model can send the turntable motion control instruction, receive and display the real time position information of three axes of turntable axis simultaneously.

## 2. System Design

The overall design of the three axis simulation system is shown in Figure 1.

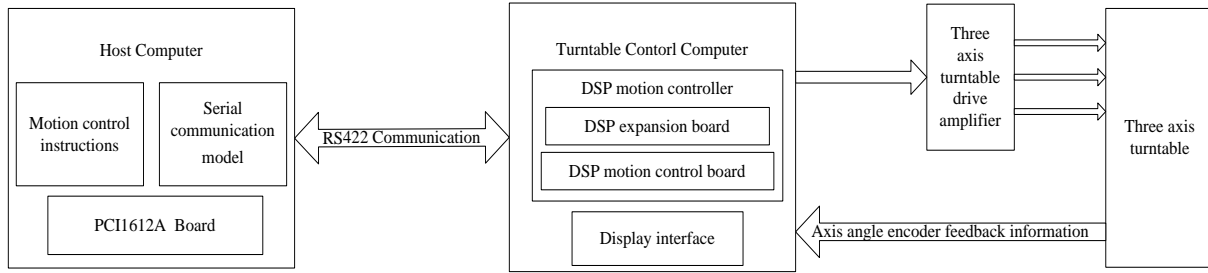

Fig. 1 The three-axis turntable simulation system

Host computer is runs in MATLAB-2014a environment. In Simulink environment, S-Function with C ++ language is used to develop serial communication model. The RTW code generator and the C compiler generate the executable code. The PCI-1612A communication card is used for fast communication. PCI-1612A is a 4 ports RS-232/422/485 PCI communication card which compatible with the PCI2.1/2.2 bus specifications, plug and play, assigned input / output address automatically, provides up to 921.6 K bps transmission rate of arbitrary baud rate set. So the host computer install PCI-1612A communication card can meet the high-speed requirement of the communication with RS-422 serial communicate.

The turntable control computer is an Advantech industrial control computer, receiving the motion control commands generated by the host computer and generating the control signals of the three axis turntable. The man-machine interface is used to display the field data output and motion parameters trajectory of the turntable. The DSP motion controller composed of the DSP motion control module and the DSP expansion module is the core of the three axis motion control. It drives the turntable to complete the movement instruction by the drive amplifier.

The three axis turntable is vertical U (external axis), U (middle axis) and T (internal axis) structure form, simulating UAV's yaw, roll and pitch separately. The real-time position information of the three axes are fed back to the turntable control computer by the axis angle encoder. It can also be displayed in the serial communication model.

## 3. Serial Communication Modeling

The serial communication module realizes the communication between the host computer and the turntable control computer. S-Function is developed for receiving and displaying real-time position information of three axes of the turntable while transmitting motion control commands. By S-Function based on C++ language, the RS-422 serial communication module is created to realize full duplex communication mode.

### 3.1 Serial Communication Protocol Description

The communication adopts custom communication protocol. An interface transmits the external, middle and internal axis data of the three-axis turntable. The data transitions between the two computers adopt the form of "record". All bytes contained in each record must be sent consecutively. Each record that the host computer sends is contains 11 bytes. The records sent by the host computer is shown in Table 1. Each record that the turntable control computer sends is contains 12 bytes. Data format is shown in Table 2.

Table 1 The command record from the host computer

Bytes 0~2	Bytes 3~5	Bytes 6~8	Byte 9	Byte 10
External axis	Middle axis	Internal axis	Status flag	Check sum

Table 2 Field record feedback from the turntable control computer

Bytes 0~2	Bytes 3~5	Bytes 6~8	Byte 9	Byte 10	Byte 11
External axis	Middle axis	Internal axis	Status flag1	Status flag2	Check sum

### 3.2 Communication Module Creation

In the actual modeling process, some models created directly with Simulink are very complex or impossible [7], while the S-Function is a good solution to this problem. S-Function is developed to create a serial port communication interface module which is shown in Figure 2. The serial communication module has the function of sending, receiving and displaying.

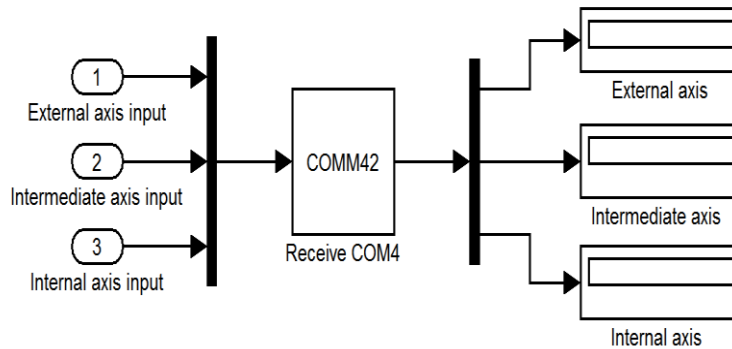

Fig. 2 Serial Communication Module

The Mux function block integrates the motion of the three axes into a frame of command and inputs serial communication module, then the commands are sent to the turntable control computer directly. The Demux function block will divide the feedback instruction received by serial communication module into the external axis, middle axis and middle axis to display. The content of the display is the three axis real-time position information of the turntable control computer's feedback to the host computer.

### 3.3 Communication Program Design and Implementation

The S-Function written in C ++ language contains the program header files that required for Windows programming. It is mainly through the preparation of API function program and use the RS-422 serial port to achieve serial communication. In the custom communication protocol, the host computer sends the instruction including the communication establishment instruction and the movement instruction. When the Initialization of the model is completed, first to send a communication command frame to establish the communication, and then send turntable motion instruction frame to achieve the turntable's control.

According to the Simulink theory [8], MdlInitialize Size callbacks function first to check the validity of input parameters in the initialization phase, where the input parameter value is 0. Then, set the numbers of input and output ports. A three-dimensional input port receives the three axis control instructions which are the host computer sent to the turntable control computer. A three-dimensional output port outputs the feedback real-time location information of the three-axis. In the mdlStart callback function, the serial number, serial baud rate and send data cycle settings are COMM4, 921600bps, 2ms respectively. The turntable control commands received by input ports are sent to the turntable control computer and the feedback commands received by the turntable control computer are set out via the module's output port are achieved via the callback function mdlOutputs in the loop phase. According to the communication protocol, the data type of the received information is converted.

After editing the program, save it in the current working directory, the Microsoft Visual C ++ 6.0 compiler is installed in Matlab, and enter mex-setup in the Matlab command window to select the Microsoft Visual C ++ 6.0 compiler. Then enter the command mex COMM42.cpp in the command window to create the C-MEX file. The generated C-MEX file can be called by Simulink.

## 4. System Test

The simulation system of three axis turntable is shown in Figure 3.

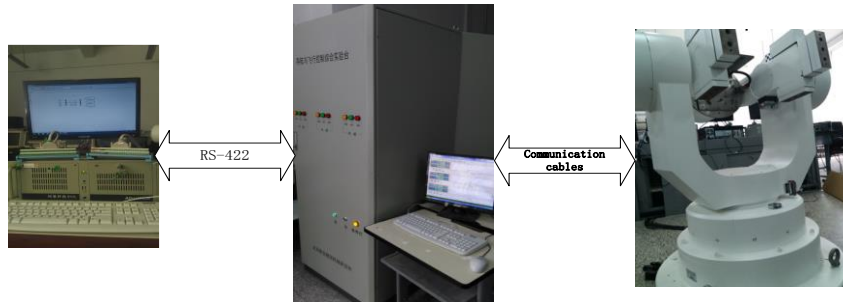

Fig. 3 The simulation system of three axis turntable

The accuracy test is given. The turntable's three axes are the initial position  $0^\circ$ . Host computer and turntable control computer baud rate is set 921600bPs. Simulation period is 2ms. The turntable control computer terminal selects serial port location simulation. Write the motion control command in the control procedure.



Fig. 4 Human-machine interface.

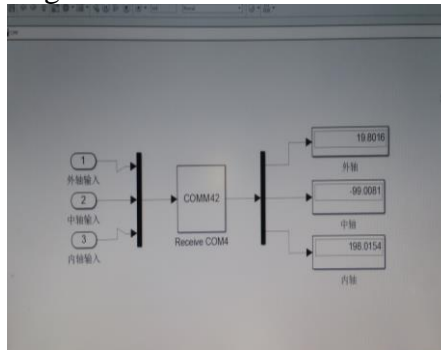

Fig. 5 Three ax real-time position of turntable

The system operation diagram is shown in Figure 4 and Figure 5. Figure 4 for the host computer sent to the turntable control computer movement command data and real-time trajectory curve.

Figure 5 for the turntable control computer feedback to the host computer of the three axis position of the turntable in real time.

The test shows that the measurement accuracy of the system is  $0.0001^\circ$ . The results meet the design requirements.

## 5. Summary

Simulated test proves that the three-axis turntable simulation control platform and the serial communication interface model designed by S-Function can effectively simulate the motion attitude of the aircraft, and ensure accurate real-time communication between simulator, turntable control computer and turntable. The system has the characteristics of stable and reliable operation, high measurement precision and short simulation period. The system has universal applicability, and the hardware-in-the-loop simulation test for UAV or Tactical missile test can be realized by setting up different simulink models and adding corresponding hardware facilities, which has good engineering practical value and popularization significance.

**References**

- [1] P. C. Zhang, Design of UAV Flight Simulation Platform Control System, *J. Computer Measurement and Control*. 08(2015) 2692-2695.
- [2] Z. C. Jiang, Y. Xie, Multi serial communication design based on embedded WinCE and MSP430 MCU, *J. Electronic Design Engineering*, 07(2011) 62-64.
- [3] V. Dobro, Developing Serial Comm Interfaces for Rapid Prototyping of Navigation and Control Tasks, *J. Aiaa Modeling and Simulation Technologies Conferece&Exhibit*, 47(2013) 669—685.
- [4] D. C. Xie, Z. W. Wang, J. T. Chen, Rapid Construction of Aircraft Control Hardware in the loop Simulation System Based on dSPACE Simulator, *J. Journal of Astronautics*, 11(2010) 2557-2562.
- [5] C. Y. Zhu, D. Yang, K. Zhai, The Implementation of The External Real-Time Simulation Environment of on-board Computer Based on dSPACE Multiprocessor Systems, *J. Acta Simulata Systematica Sinica*, 16(2004) 2298-2293.
- [6] K. Zhai, D. Yang, C. Y. Zhu, Real Time Simulation System for Attitude and Orbit Control System of Flexible Satellite Based on dSPACE, *J. Aerospace Control*, 01(2004)17-25.
- [7] P. Kang, Z. Su, Q. Li, a Modeling and Simulation Method of Flight Vehicle Based on Matlab/S-Function, *J. Micro Computer Information*. 04(2009) 217-218.
- [8] C. P. Kang, Z. Su, Q. Li, a Modeling and Simulation Method of Flight Vehicle Based on Matlab/S-Function, *J. Micro Computer Information*. 04(2009) 217-218.