

Design of a Reciprocating Sprout Harvester

GUO Yi

Department of Horticulture, Beijing Vocational College of Agriculture, Beijing, 102442, China

guoyibvca@163.com

Keywords: Reciprocating; Harvester; Sprout; Reciprocating Device; Matlab

Abstract. This reciprocating sprout harvester is designed to solve the issues including high labor intensity, low work efficiency as well as difficulty in ensuring reaping quality regarding manual sprout harvesting. SolidWorks software is adopted to conduct 3D modeling of every part as well as the overall unit and form the mathematical model of kinematic analysis of the reciprocating device. Matlab language is applied to work out the rules for the change in plate groove displacement and velocity line acceleration. As for the reciprocating sprout harvester based on this design, the application test shows that single-disk harvesting time is 10s; compared with manual harvesting, work efficiency increases by more than 300%; moreover, labor intensity is reduced; stubbles after reaping are neat and consistent so as to reduce loss of reaping by more than 20%. Moreover, such mechanism is characterized by simple structure, convenience operation, safety and low manufacturing cost. This harvester effectively solves the issues relating to mechanization of sprout reaping, so it has a good prospect for extension.

Introduction

Sprouts are characterized by freshness, unique flavor, rich nutrition and freedom from pollution. It also contains a variety of amino acids, minerals and vitamins with many health-care functions. Besides, as sprouts have a short production cycle, high efficiency, low investment, quick economic return and high profit, it has gained increasing favor and attention from consumers as a whole. Large-scale production of sprouts can bring remarkable economic benefits [1].

As a kind of 3D parameterized design software, SolidWorks is characterized by simple operation, which greatly increases efficiency of design. Having comprehensive part entity modeling function and compact part quick assembly function, SolidWorks is also able to conduct dynamic constraint check automatically. SolidWorks has been widely applied in varied mechanical design fields. By applying SolidWorks software, Guo Yi, et al. have completed the design of atomizing cultivation device for sprouts [2], Yao Penghua, et al. have completed 3D modeling of the weeder [3], Guo Yingjie, et al. have formed 3-D model of the crushing & throwing device of the compactor [4], Guo Yi, et al. have completed design of canopy aerosol culture [5], Ding Yaqing, et al. have completed design and analysis of improvement of wearable parts of the pickup of the strapping unit [6], Jiang Yanwu, et al. have completed design of the potato sorter [7], and Yang Zhichao, et al. have completed design of the trailed bale crusher [8].

As mathematical software produced by US MathWorks for commercial purpose, Matlab has very powerful functions of engineering calculation and numerical analysis, which are characterized by a unique advantage if applied to analysis of mechanical motion. Tian Liquan, et al. applied Matlab to conduct research of ejection trajectory of budded seed of rice during seeding by rice precision direct seeding apparatus [9]. Wang Chao, et al. applied Matlab to optimization design and analytic solution of the pick-up arm of the round straw pickup truck [10]. Han Zhenhao, et al. applied Matlab to the design and parameter optimization for the top seedling mechanism of fully automatic transplanter [11]. Li Yongbo, et al., based on Matlab, conducted optimization design for the new type rotary cultivator [12].

At present, sprouts are reaped by men with shears, which is characterized by high labor intensity, low work efficiency and difficulty in guaranteeing reaping quality. In this paper, we introduce a reciprocating sprout harvester characterized by a simple structure, convenient operation, safety and low manufacturing cost so as to solve the problems relating to mechanization of sprout harvesting so

as to reduce labor intensity, increase work efficiency and guarantee operation quality for sprout reaping.

Integral Construction and Workflow

The reciprocating sprout harvester is mainly made up of the frame, the cut-off unit, the reciprocating apparatus, the feed box, the shield and the control system (Fig.1). The frame is applied to install varied parts. The reaping apparatus is installed in the center of the upper part of the frame for the purpose of conducting sprout harvesting. The reciprocating apparatus is installed on the upper part of the frame for the purpose of controlling reciprocating movement of the seedling tray so as to realize feeding of the sprouts to be reaped and output of the seedling tray of the sprouts reaped. The feed box is installed on one side of the center of the frame for the purpose of collecting the reaped sprouts. The shield is installed on the upper part of the frame for the purpose of preventing injury brought to the operator by any moving part. The control system is used to control start and cease of the reciprocating apparatus and the cut-off unit.

The workflow of the harvester is as follows: First, press the start button to enable the control system to work. Then, place the sprouts to be reaped along with the seedling tray inside the disc groove manually. When sensor A installed at the bottom of the tray groove detects the seedling tray, start the reciprocating apparatus to enable the sprouts to be reaped to move towards the cutter. When the sprouts reach the cutter, sensor B installed on the front part of the cutter detects the tray groove and cut-off unit starts and continues to move with the reaped sprouts. The cutter starts the reaping of sprouts. The reaped sprouts are placed on the upper part of the cutter with the assistance of the baffle. When the tray groove moves behind the cutter, the cutter stops working. In the meantime, the sprouts stored on the upper part of the cutter fall into the feed box under the action of gravity. The tray groove starts to move out so as to complete one round of sprout reaping. Take out the seedling tray manually and place into tray for the sprouts to be reaped again for the next round of harvesting. Press off button to finish work of system after completion of all harvesting.

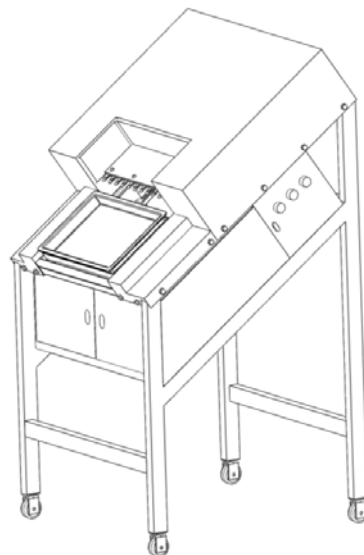

Fig. 1 Sketch of the reciprocating device

Design of Parts

Design of the Frame. The frame is built by welding stainless steel, and made up of the column, the beam and the caster (Fig.2). Based on the specifications of the seedling tray used for the production, width of the frame is designed as 605mm. Based on the size of the reciprocating apparatus, length of the frame is designed as 640mm. The slide of the reciprocating apparatus is installed on one side of the top of the frame, the electrical motor as well as the transmission box of the reciprocating apparatus are installed on the other side. The reaping apparatus is installed in the center of the top of the frame.

The feed box is installed on one side inside the frame. The frame appears sloped for the convenience of all reaped sprouts to quickly fall into the feed box under the action of gravity.

Design of the Cut-off Unit. The cut-off unit is made up of the electric motor, the transmission box, the upper blade, the lower blade, the fixed film and the baffle (Fig.3). The electric motor supplies power to the transmission box. The transmission box includes the housing, gear reducer and double-cam actuated mechanism. The upper and lower blades are linked to the fixed film and the baffle by the bolt and the axle sleeve. The double-cam-actuated mechanism drives the upper and lower blades to conduct reciprocating motion in the opposite direction. The blade teeth form shears to reap sprouts. The baffle is applied to collect the reaped sprouts.

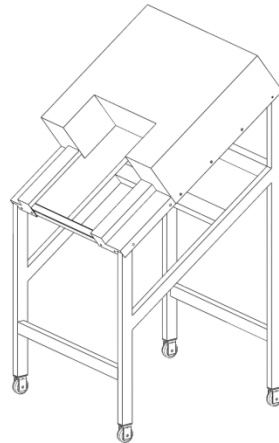

Fig. 2 Frame

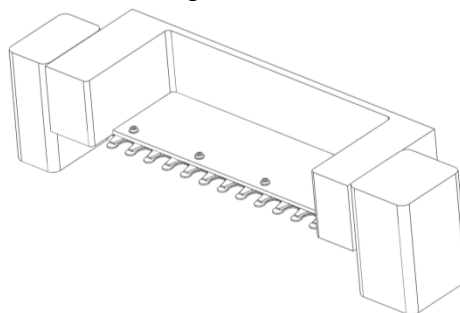

Fig. 3 Cut-off unit

Design of the Feed Box. The feed box is made up of stainless steel plates welded with an opening on the upper side, composed of the box bottom, the side wall and box door (Fig.4). It is installed on one side within the frame on the lower part of the slide for the purpose of collecting the reaped sprouts. Open the box door to take reaped sprouts out after operation for a certain period. Based on dimensions of the frame, length, width and height of the feed box is designed as 610mm*478mm*180mm.

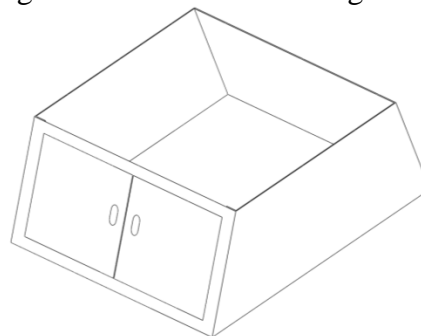

Fig. 4 Feed box

Design of the Reciprocating Apparatus. The reciprocating apparatus is made up of the electric motor, the transmission box, the crank, the connecting rod, the slider, the slide and the tray groove (Fig.5). Based on the working process of this harvester, in order to realize intermittent service and guarantee safety of the operator and reaping quality, the stepper motor is selected. Under the control by the control system, the stepper motor spins in a circle upon every service, leading the crank to spin

in a circle so as to enable the tray groove with the slider installed to conduct reciprocating motion once along the slide via the connecting rod. Then the next round of operation starts upon arrival of sensor A's release signal. The structural parameters of the reciprocating apparatus are shown in Table 1.

Table 1 Structural Parameters of Reciprocating Apparatus

Item	Structural parameter
Length of the crank	130mm
Length of the connecting rod	180mm
Length of the slider	85mm
Length of the slide	455mm
Length, width and height of the tray groove	320mm*210mm*20mm

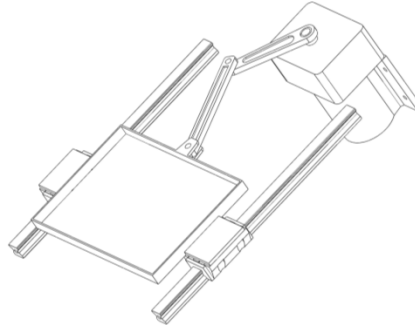

Fig. 5 Reciprocating apparatus

Design of the Control System. The control system is made up of the main control chip, sensor A, sensor B, on-button, off-button and the leakage protector. As a single chip, the main control chip receives the signals from sensor A and sensor B via the program to bring the reciprocating apparatus and the cut-off unit under control. Installed at the bottom of the tray groove, sensor A receives release signals. Sensor B is installed on the front part of the cutter to receive cutting signals. On-button is applied to actuate the harvester. Off-button is applied to stop the harvester. Leakage protector may guarantee automatic cut-off of power supply upon leakage of the harvester so as to guarantee safety of the operator.

Kinematic Analysis of Reciprocating Apparatus

Motion of the reciprocating apparatus determines efficiency and quality of sprout reaping. Therefore, kinematic analysis of the reciprocating apparatus is highly important to rationality of design of the harvester.

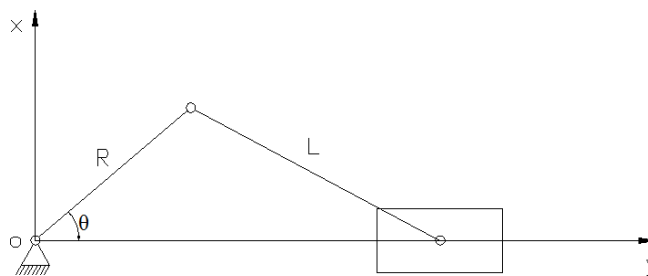

Fig. 6 Sketch of the reciprocating device

Set up Mathematical Model of Kinematic Analysis. Based on the structure of this harvester, the slider crank mechanism is adopted for the reciprocating apparatus can be simplified as Fig.1. For the purpose of kinematic analysis of the reciprocating apparatus, set up rectangular coordinate system shown in Fig.6 with rotational center of crank as the origin, horizontal direction as x axis, and vertical direction as y axis. Kinematics equation based on Fig.1 is as follows:

$$s = R \cdot \cos\theta - R^2/4L \cdot \cos2\theta + L - R^2/4L \tag{1}$$

$$v = -\omega R^2/2L \cdot \sin2\theta + \sin\theta \tag{2}$$

$$a = -\omega^2 R(R/L \cdot \cos 2\theta + \cos \theta) \quad (3)$$

In the equation:

- s -displacement of tray groove [mm];
- R -length of crank [mm];
- L -length of connecting rod [mm];
- θ -crank angle [$^\circ$];
- ω -crank angle speed [rad/s];
- v -linear velocity of tray groove [mm/s];
- a -linear acceleration of tray groove [mm/s²].

Kinematic Analysis. Based on the above-mentioned mathematical model of kinematic analysis, and by the program made with Matlab language, calculate displacement, speed and acceleration of the tray groove with equation, and draw variation curve to obtain the rules for variation of displacement, speed and acceleration of tray groove. Regarding this design: crank A and crank B rotate anticlockwise at uniform angular velocity ω as 0.63rad/s; length of the crank R is 130mm; length of the connecting rod L is 180mm. Obtain the rules of variation of displacement s , speed v and linear acceleration a of the tray groove by the program. See Fig.7.

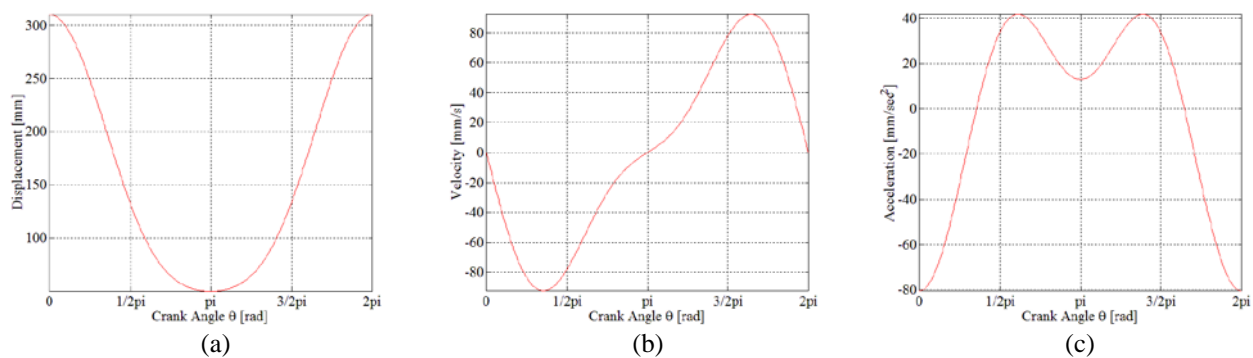

Fig. 7 Results of kinematic analysis

a-rule of variation of displacement b-rule of variation of speed c-rule of variation of acceleration

Based on the above-mentioned kinematic analysis, we can draw a conclusion that the rules of variation of kinematic parameters as displacement, speed and acceleration of the tray groove can meet the requirements for sprout feeding and output of the seedling tray.

Conclusions

The sprout reciprocating harvester based on this design has been tested by Beijing Green Mountain Sprout Co., Ltd. The results show that time for reaping in one round is 10s; when the operator is sufficiently proficient in taking out and placing the cultivation tray, the harvest per hour reaches 180, thus compared with manual reaping, work efficiency increases by more than 300%; besides, labor intensity is reduced. The neat cutting of the harvest reduces the loss caused by uneven cutting by more than 20%.

This mechanism is characterized by simple structure, convenient operation, safety and low manufacturing cost. It has effectively solved the problems of mechanization sprout reaping, reduced labor intensity of harvesting, increased work efficiency and guaranteed operation quality with a bright prospect for promotion.

The storing tray of the reciprocating sprout harvester described in this article is operated manually. Based on this research, mechanical device for the tray will be designed in the future to improve the level of mechanization for the harvester.

Acknowledgements

This paper is funded by "Demonstration and Promotion Project of the Sprout Harvester" (Project No. XY-YF-16-01) of Technology Development and Demonstration and Promotion Fund of Beijing Vocational College of Agriculture.

References

- [1] Guo Yi, ZHANG Guiqin. Development of A Design System for the Sprout Vertical Cultivation Device[J]. Advances in Engineering Research. 2015(26):206-211.
- [2] Guo Yi, Chen Lanfen, Suo Lang Jin Zong, Yang Zhen. Design of Sprout Aeroponics Equipment[J]. Advances in Engineering Research, 2016, (88): 1783-1789.
- [3] YAO Penghua, LIU Peng, YAO Zhihua. Three Dimensional Design of Weeder and Finite Element Analysis [J]. Equipment Manufacturing Technology, 2017, (03):27-28+39.
- [4] GUO Yingjie, CAO Zifu, ZHAO Wanning. Optimization analysis on dynamic balance of crushing and throwing device of bundling machine Based on ADAMS[J]. Journal of Chinese Agricultural Mechanization, 2017, (03):1-4+13.
- [5] Guo Yi, Chen Lanfen, Zhang Guiqin. Design of a Sprout Layer-rack Aeroponic Cultivation Device[J]. Advances in Engineering Research, 2016,(104): 395-400.
- [6] DING Yaqing, YANG Zhichao, ZHANG Lihong. Improved design and analysis of vulnerable components of pickup on packing Machine[J]. The Journal of Chinese Agricultural Mechanization, 2017, 38 (1):37-40.
- [7] JIANG Yanwu, WEI Hongan, LU Xianghui, HUANG Xiaopeng, SHI Mingming. Design of potato tuber sorter[J]. Journal of Gansu Agricultural University, 2017, (01):139-143.
- [8] YANG Zhichao, ZHANG Yun, LIU Zhongshe. A Towed Bale Unpacking Machine Design and Experimental Research[J]. Journal of Agricultural Mechanization Research, 2017, (12):78-83.
- [9] TIAN Liquan, TANG Han, WANG Jinwu, LI Shuwei, ZHOU Wenqi, YAN Dongwei. Design and Experiment of Rebound Dipper Hill-drop Precision Direct Seed-metering Device for Rice[J]. Transactions of the Chinese Society for Agricultural Machinery, 2017, (04):65-72.
- [10] WANG Chao, ZHANG Yun, LIU Zhongshe. The Structure Optimization of Picking-up Arm with the Method of Analysis and Solution Based on CAXA and Matlab Software[J]. Journal of Agricultural Mechanization Research, 2016, (09):180-185.
- [11] HAN Zhenhao, YAN Hua, CHEN Ke, WANG Haifeng, XU Pan, HE Yakai. Design and Parameter Optimization of Seedling Expeller Mechanism Based on Matlab[J]. Journal of Agricultural Mechanization Research, 2017, (01):142-146.
- [12] LI Yongbo, YU Hong, ZHANG Ruihong, TAO Deqing, XI Xiaobo, WANG Mingyou. Optimization design for a new kind of bi-Axial rotary cultivator based on Matlab[J]. The Journal of Chinese Agricultural Mechanization, 2016, 37 (3):04-06.