

Optimal Model Of Bus Dispatching Scheme

Yumeng Zhang

Dalian NO.12 middle school, Dalian, 116018,China

446982051@qq.com

Keywords: Optimal model; Bus dispatching scheme

Abstract. Based on the analysis of a city bus lines of passenger flow investigation and operation data, establish the optimization model of bus scheduling scheme, the bus company in certain social and economic benefit of the premise, given the ideal scheme of bus scheduling. established the maximum passenger capacity, the mathematical model of grid vehicle number, given by decision method each time the maximum passenger capacity to meet the bus number, full load rate and the load end of each period all the passengers under that car every day at least 462 times, the minimum number of vehicles to 60 vehicles; and gives the whole timetable.

Introduction

Public transportation is an important part of city traffic, for the bus scheduling to improve the city traffic environment, improve public travel, improve the bus company's economic and social benefits, is of great significance. Bus companies to develop a bus scheduling program, need to consider all aspects of factors. Known operating conditions and scheduling requirements are as follows:

- (1) there are 14 stations on the direction of the bus line, and 13 stations in the down direction.
- (2) bus line bus company is allocated to the same type, a standard capacity of 100 people, according to statistics on the average speed of bus line runs 20 km / h, load rate should not exceed 120%, generally not less than 50%.
- (3) passengers generally do not wait for more than 10 minutes, the morning peak is generally not more than 5 minutes.

Problems to solve:

- (1) according to these data and requirements, design a convenient operation for the all day long line (working day) the bus scheduling scheme, including two starting point station timetable; the number of cars; the scheme to what extent to take care of the passengers and the bus company and the interests of both sides.
- (2) how to abstract the scheduling problem into a clear and complete mathematical model, and point out the method of solving the model.

Analysis of Problems

The problem requires us to design a bus dispatching, which should take into account the improvement of urban traffic environment, improve the public travel situation, improve the economic and social benefits of the bus company and many other factors. If you only consider improving the bus company economic benefits, as long as the increasing loading rate of the bus, the use of data analysis can give the best scheduling scheme for it; if you only consider the convenience of passengers, as long as the increase of vehicle number, the use of statistical methods can also be convenient to give it the best scheduling scheme. Obviously, the two schemes are antagonistic. So we divide the question into two parts, which are considered separately.

Symbol Description

a_{ijk} : plink or downlink J time K station number.

b_{ijk} : uplink or downlink J time K station number.

l_{ij} : the maximum passenger flow upward or downward in J period.

- z_{ij} : uplink or downlink J time average number of passengers.
- c_{ij} : a vehicle uplink or downlink J time.
- C : on the total train departure.
- s_{ij} : uplink or downlink J time average departure time.
- $F[s_{ij}]$: uplink or downlink J period when the departure time is decimal, down integer.
- $C[s_{ij}]$: uplink or downlink J period when the departure time is decimal, integer is rounded up.
- mc_i : the average satisfaction of passengers on the uplink or downlink.
- mc_{ij} : uplink or downlink J time passenger satisfaction.
- t_{ij} : the j uplink or downlink period of passenger waiting time.
- mc_t : passenger car equivalent time satisfaction.
- mc_w : the comfort of bus passenger satisfaction.
- mg_i : up or down the bus company on average satisfaction.
- mg_{ij} : uplink or downlink J time the bus company's satisfaction.
- $i=1$: indicates that the upstream movement (at this time $k=1, 2, 3, 14, \dots$).
- $i=2$: the downward motion (when $k=1, 2, 3, 13, \dots$).
- $j=1, 2, \dots, 18$: each time the bus from 5:00 to 23:00 operation.

Model Assumptions

- (1)Traffic conditions, road conditions are good, no traffic jams and vehicle damage and other accidents.
- (2)During the normal business period, the latest departure time of the bus company shall not exceed 20 minutes.
- (3)Bus departure interval integer minutes, moving the bus and not miss each other to overtake, end point station for the U-turn departure.
- (4)The number of passengers arriving at the station at each time is considered as a negative exponential distribution. Passengers travel in accordance with the principle of queuing in order, without waiting in the interval of two vehicles.
- (5)Data sources, reliability, stability, and Science in the census sheet.
- (6)The fare is 2 yuan, not because of the distance between the car and the change.
- (7)In order to facilitate the narrative, the bus operation time 5:00~23:00 is divided into 18 time periods, respectively 1, 2, and 18.

The Establishment and Solution of The Model

Problem 1 is to design a bus dispatching plan which is easy to operate. According to table two passengers a day off the direction of each station on the 1, table 2 the number of statistics, to meet the bus after each time period the number of passengers, it must be able to end each time the number of passengers carrying the number reaches the maximum, thereby establishing a model to determine the departure time table, calculate the vehicle the number of the problems in analysis.

The maximum capacity of each period of uplink and downlink, and establish the model as follows:

$$I_{ij} = \begin{cases} \max \sum_{k=1}^m (a_{ijk} - b_{ijk}) & (i = 1, m = 1, 2, \dots, 14) \\ \max \sum_{k=1}^m (a_{ijk} - b_{ijk}) & (i = 2, m = 1, 2, \dots, 13) \end{cases} \quad (j=1, 2, \dots, 18) \quad (1)$$

Use model and Table 1, Table 2 up and down passenger number, calculate up and down each time period inside biggest passenger capacity.

Upstream direction:

701, 2943, 5018, 2705, 1528, 1193, 1355, 1200, 1040, 881, 871, 2133, 2772, 897, 464, 410, 275, 19.

Down direction:

27, 1039, 2752, 3223, 1822, 1093, 986, 830, 891, 1017, 1302, 2196, 3612, 2417, 1091, 781, 774, 337.

the departure time of each period: as the bus carries 100 passengers per vehicle, the vehicle load rate is between 50%~120%, and when Z_{ij} is close to 120, the model consists of:

$$c_{ij} = \begin{cases} \left\lceil \frac{l_{ij}}{120} \right\rceil + 1, & \frac{l_{ij}}{120} \notin Z^+ \\ \frac{l_{ij}}{120}, & \frac{l_{ij}}{120} \in Z^+ \end{cases} \quad C = \sum_{i=1}^2 \sum_{j=1}^{18} c_{ij} \quad (2)$$

Can calculate the departure times of CIJ each time, for the morning and evening hours, uplink 22:00~23:00 maximum capacity for 19 people, down 5:00~6:00 maximum capacity for 27 people, but the bus company to meet not later than 20 minutes, then departure trips are as follows:

Uplink: 6, 25, 42, 23, 13, 10, 12, 10, 9, 8, 8, 18, 24, 8, 4, 4, 3, 4.

Descending: 3, 9, 23, 27, 16, 10, 9, 7, 8, 9, 11, 19, 31, 21, 10, 7, 7, 4.

So get the minimum total number of calls throughout the day

$$C = \sum_{i=1}^2 \sum_{j=1}^{18} c_{ij} = 231 + 231 = 462 \quad (3)$$

arrange the departure time interval: take the average departure time interval of 60 by the number of vehicles per time interval: $s_{ij} = 60 / c_{ij}$, as follows:

Uplink: 10, 2.4, 1.4, 2.6, 4.6, 6, 5, 6, 6.7, 7.5, 7.5, 3.3, 2.5, 7.5, 15, 15, 20, 20.

Descending: 20, 6.7, 2.6, 2.2, 3.8, 6, 6.7, 8.6, 7.5, 6.7, 5.5, 3.2, 1.9, 2.9, 6, 8.6, 8.6, 20.

The value of s_{ij} has a decimal point, but in reality the minimum unit of timetable for trains, buses, etc. is minute. Therefore, in order to plan the actual operability of the scheme, it should be adjusted to the full interval. When the s_{ij} integer, can be directly arranged at c_{ij} ; when the s_{ij} fraction, say $F[s_{ij}]$ and $C[s_{ij}]$ interval trips to m_{ij}, n_{ij} ; $F[s_{ij}] \leq s_{ij} \leq C[s_{ij}]$, by model:

$$\begin{cases} m_{ij} \times F[s_{ij}] + n_{ij} \times C[s_{ij}] = 60 \\ m_{ij} + n_{ij} = c_{ij} \end{cases} \quad (i=1, 2; j=1, 2, \dots, 18) \quad (4)$$

Can be calculated by $F[s_{ij}]$ frequency m_{ij} interval and $C[s_{ij}]$ interval of the frequency of n_{ij} , respectively, with the departure interval is $F[s_{ij}]$ and $C[s_{ij}]$, both the grid density, in order to make the vehicle should not be scheduled at the same time line too much, we order to adjust the integration interval corresponding to the amount of adjustment will start. The interval of adjacent time equal divisions as far as possible together, come all day long (one day) the bus scheduling scheme in the annex (four).

the number of vehicles required per day. The average speed of 20 km/h and A0-A13 at a distance of 14.61 km, 14.58 km from the A13 A0, can be obtained from the starting point to the end point of vehicle station station for 44 minutes on average with the assumption that the vehicle arrived; immediately after returning to the end point. Since the number of passengers in the morning peak is the maximum, the actual number of vehicles occupied should be the upper limit of the day. If the bus company can send the car at the minimum, it will meet the number of vehicles required per day.

The maximum number of vehicles early peak period: taking into account the least when the vehicle meet down the bus, the upstream than downstream direction of the vehicle to start, we based on the time of departure trains c_{ij} , adjusted $F[s_{ij}]$ and $C[s_{ij}]$ bus departure interval, one-way running time of 44 minutes, each time dynamic analysis A0, A13 station available the bus number and departure as in figure two.

5:00~6:00 uplink and downlink departure:

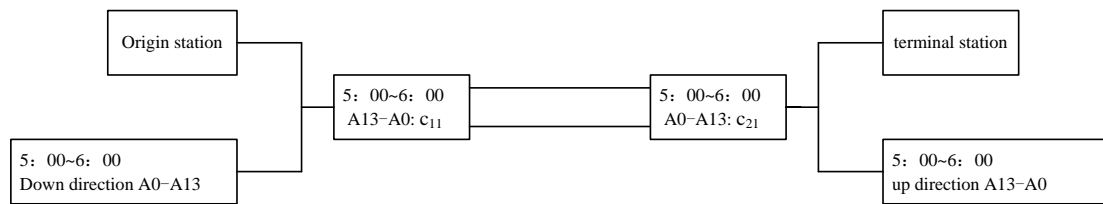

Figure 1. Finite 5:00-6:00 uplink and downlink departure model

6:00~7:00 uplink and downlink departure:

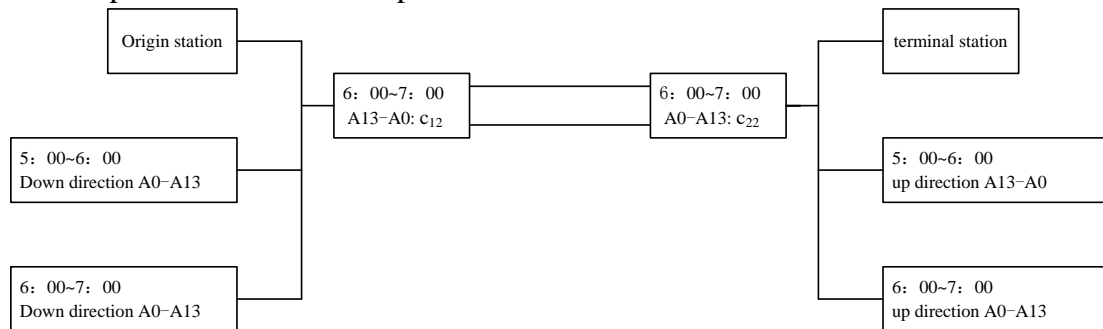

Figure 2. Finite 6:00-7:00 uplink and downlink departure model

The conclusion

From the bus can be analyzed every time the situation, the peak vehicle occupancy of 60 vehicles, A13 station number of vehicles required 51, A0 station number of vehicles required 9, that is, the day required to start the vehicle at least 60 vehicles.

Reference

- [1] Galay Barbarosoglu, Linet Ozdamar, Ahmel Cevik. An Interactive Approach of Hierarchical Analysis of Helicopter Logistics in Disaster Relief Operations[J]. European Journal of Operational Research, 2002: 118-133
- [2] Sriram Venkataramanan, Atilla Dogan. A Multi-UAV Simulation for Formation Reconfiguration[R]. AIAA2004-4800. Providence, Rhode Island: AIAA Modeling and Simulation Technologies Conference and Exhibit, 2003
- [3] M.Valenti, T.Schouwenaars, Y.Kuwata, E.Feron and J. How Implementation of a Manned Vehicle-UAV Mission System[C]. AIAA Guidance, Navigation and Control Conference, Providence, RI, August 2004, AIAA2004
- [4] M.Ben-Bassat. Knowledge Requirement and Management in Expert Decision Support Systems for (Military) Situation Assessment[J]. IEEE Trans. on SMC. 1982, 12(4):479-490
- [5] Jerome Azarewicz, Glenn Fala. Template-based Multi-agent Plan Recognition for Tactical Situation Assessment[A]. In: Proceedings of 5th conference on Artificial Intelligence Applications[C], March 1989:247-254
- [6] G.Peterson, L.Axelsson, T.Jensen, et al. Multi-source Integration and Temporal Situation Assessment in Air Combat[J]. Proceedings of Information Decision and Control. 1999:371-375
- [7] Ge S S, Cui Y J. Dynamic motion planning for mobile robots using potential field method[J]. Autonomous Robots, 2002, 13:207-222