

The Design of Automatic Silk Material Replacement Device on 3D Printers Based on FDM Technology

Jian-Bin WANG^a, Ji-Shu YIN and Yu-Lin

School Of Mechanical Engineering, Nanhua University, Hengyang, China

^awangjb188@163.com

Keywords: 3D Printers ,FDM technology, Silk Material Replacement Device

Abstract. The overall design of the mechanical structure of the color 3D printer is put forward, and a new spliced print head structure is proposed. The utility model relates to a splicing type print head, which is composed of a print head which is loaded with different colors of silk material and a movable fixing device of a spray head. The print head spliced through a nozzle fixing device of an elastic spring mechanism locking positioning clamping space forming and the print head, the splicing type print head in the two part of the implementation of the print head movement path splicing preset, and then through the automatic replacement process of printing head fixing device and mobile splicing nozzle with different colors from to achieve different color silk. An automatic replacement device of the wire material is designed. By testing the automatic replacement device of the wire material, it is proved that the automatic replacement of silk material in line with color 3D printing in the automatic replacement of silk material requirements.

Introduction

Although 3D printing based on FDM technology has been applied widely, 3D printing technology will be pushed to a higher level and the entire 3D printing industry will be armed with huge potential room for development with the further development of manufacturing^[1,2]. In the future, 3D printers will move towards miniaturization and enlargement trends, ^[3,5] among which compact 3D printers are mainly 3D printers based on FMD technology. Nowadays, products printed based on FDM technology feature single color, however, many products in real life such as portrait, jewelry crafts and many more are hoped to be formed directly by color printing, so color 3D printers based on FDM technology have a broad market prospect.

FDM technology is the Fused Deposition Modeling Technology, and its working principle is that the filamentous hot-melt material (ABS, PLA, etc.) is sent into the hot melt nozzle through the silk feeding mechanism, and the filamentous material in the nozzle is heated and melted by the thermocouple, while the nozzle moves along part level outline and fill track under the control of the computer, and squeezes out molten material and deposits it in a specified position for rapid solidification.

After a layer of molding is completed, the machine table changes a height (that is the slice thickness) and then molds the next layer continuously until the entire physical modeling is formed ultimately. FDM technology obtains the structural information of any complex shape directly from computer graphics data processing, which deposits into molding products through melting and prints any geometric structure; besides, it possesses many characteristics such as fast manufacturing process, harmless printing products, low machine noise, miniaturized volume, convenient operation in the office or home and extensive application prospects. However, in order to achieve multi-color printing of color 3D printers based on FDM technology, it needs to be able to replace silk material of different colors, so the research of silk material replacement device has become the key to the success of color 3D printers^[6,7].

The design principle of automatic silk material replacement device

To meet the requirement of actual working condition and silk material replacement of 3D printers based on FDM technology, automatic silk material replacement device should follow the following three design principles:

- (1) Strength principle: As the most basic criteria for mechanical design, the designed device must meet the strength requirements during working process, otherwise the parts would fail.
- (2) Optimal size principle: 3D printers based on FDM technology have small volume, which requires the designed silk material replacement device to achieve compact structure as far as possible under the premise of meeting strength requirements.
- (3) Reliability principle: At present, the precision of 3D printers based on FDM technology can generally reach 0.1mm, which requires silk material replacement device to be lightweight, reducing movement inertia of the device during printing process and improving stability and reliability of the print head.

The determination of the design scheme of automatic silk material replacement device

In the 3D printers based on FDM technology, Fig. 1 is a typical structure of extruder nozzle. The silk material enters into filament guide tube from the center hole of the top of the extruder nozzle, after being melted in hot melt cavity and then squeezed out by the nozzle.

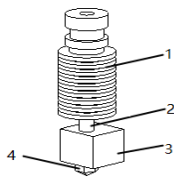

1 Heat sinks; 2 Filament guide tube ; 3 Hot melt cavity; 4 Nozzle

Fig.1 Extruder nozzle

During the printing process, the silk material has been sent into extruder nozzle continuously from the feeding mechanism, and if single extruder nozzle is directly used, it is difficult for two types of silk material to replace. Therefore, it is necessary to adopt the multiple extruder nozzle scheme, each extruder nozzle being responsible for the supply of one color silk material. It is relatively easy to take total replacement of extruder nozzle.

Adopting the multiple extruder nozzle scheme to achieve refueling process, the core issue of its design is how to replace the extruder nozzle. In the field of metal materials 3D printing, the hybrid manufacturing equipment has been developed recently, integrating 3D printing and traditional cutting machining together, which is equivalent to a tool in the machining center can be replaced. The extruder nozzle in color 3D printers is also analogous to the tool in the machining center, the nozzle library with multiple nozzle being set, and one extruder nozzle in the nozzle library being replaced by another when silk material is replaced.

On account of self- characteristics of 3D printers based on FDM technology and the design principle of automatic silk material replacement device, the design scheme of automatic silk material replacement device has been determined. Its design scheme is as follows: the automatic silk material replacement device consists of the combined extruder nozzle and the nozzle library. The nozzle library loads with a number of extruder nozzles of silk material in different colors, which hang on the outer frame of the printer, being in a zigzag arrangement. The combined extruder nozzle contains two parts: the extruder nozzle and the nozzle fixing plate. The nozzle fixing plate is mounted on the X-axis of the inner frame of the printer and can be moved along XYZ three directions by the driving of motor. Once the movement path of nozzle fixing plate being set, it can be connected automatically with extruder nozzle of a certain color in the nozzle library to form a complete extruder nozzle to start

printing, and after the extruder nozzle finishing the printing job of that color and being hanged back to the nozzle library, it takes extruder nozzle of another color to print, thus achieving color 3D printing. Fig. 2 shows the overall frame and automatic silk material replacement device of the color 3D printer.

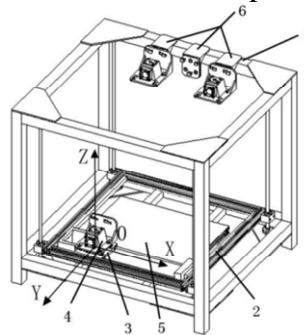

1 Outer frame; 2 Inter frame; 3 Nozzle fixing plate; 4 Extruder nozzle; 5 Workbench board; 6 Nozzle library

Fig.2. overall frame and automatic wire material replacement device

The design of the spliced print head on silk material replacement device

The combined extruder nozzle is made up of two parts: the nozzle fixing plate and the extruder nozzle. As shown in Fig. 3.1, the nozzle fixing plate is mounted on the X-axis of the printer and connected to the X-axis pole by a linear bearing, which can move along the X-axis pole by the driving of motor, besides, the X-axis pole can move along the Y-axis direction and the inner frame of XY axis can move along the Z-axis direction, thus achieving the nozzle fixing plate's free movement in XYZ three directions. The nozzle fixing plate is composed of the base, the cylindrical coil spring, the countersunk screw, the spring seat and the synchronous-belt pressing block. Four countersunk screws are distributed on the upper surface of the base uniformly, each of which has a cylindrical coin spring providing the pre-tightening force, the lower end of the spring being mounted on the upper annular groove of the base and the other end against the spring seat under the head of the countersunk screw. The height of the spring can be adjusted by the penetration depth of countersunk screws to change the size of the pre-tightening force. The holding space of elastic locking positioning is formed between the countersunk screw on the base and the spring seat. The upper surface of the base is provided with a synchronous-belt pressing block, synchronous belt is sandwiched between the base and the pressing block. The synchronizing belt drives the whole nozzle fixing plate to move in the X-axis direction under the driving of motor by screw locking.

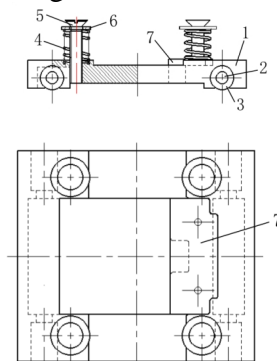

1 Base; 2 X-axis pole; 3 Linear Bearings; 4 Cylindrical coil spring; 5 Sunk screw; 6 Spring seat; 7 synchronous-belt pressing block

Fig. 3.1 Structure chart of the extruder nozzle fixing plate

The structure of the extruder nozzle is shown in Fig. 3.2. The extruder nozzle consists of the nozzle, the thermocouple, the circular radiator, the radiator fan, the installation block, the pressing block and the L-shaped plate. The nozzle, thermocouple and circular radiator connect from the bottom to the top, being mounted on the installation block, and the top of the circular thermocouple is slightly

higher than the installation block, pressing the radiator to the installation block by the pre-tightening force provided by the screw between the mounting block and the briquette. The front end of the mounting block is equipped with a cooling fan, providing heat dissipation for 3D printing, and an opening for the thermocouple wire trace lay at the back end. The bottom of the installation plate is fastened to the bottom plate of the L-shaped plate with four screws. The bottom plate of the L-shaped plate has four sets of gourd-shaped positioning holes corresponding to the countersunk screws on the nozzle plate, the diameter of the big head being slightly larger than that of the countersunk screw, the diameter of the small head being slightly larger than that of the screw on the countersunk screw. The position of the hole is the same as it of the countersunk screw on the nozzle head, the diameter of the big head being slightly larger than it of the head of the countersunk screw, the diameter of the small head being slightly larger than it of the screw, and the upward side of the small end on the gourd-shaped hole chamfers, the outer diameter of the chamfer position matching the head of the countersunk screw. There are two trapezoidal holes on the side plate of the L-shaped plate corresponding to the hook of the nozzle, which comprises a big-hole end matching the outer diameter of the hook step and a small-hole end matching the outer diameter of the hook shaft.

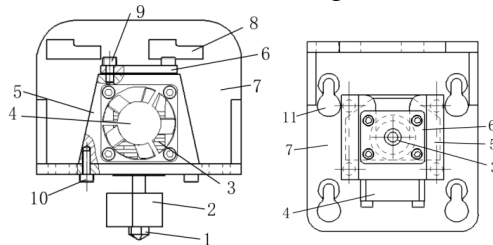

1 nozzle; 2 thermocouple; 3 circular radiator; 4 radiator fan; 5 installation block; 6 pressing block; 7 L-shaped plate; ; 8 Trapezoidal hole; 9 pressing block bolt; 10 installation block bolt; 11 gourd-shaped hole

Fig.3.2 Structure chart of the extruder nozzle

Print sprinkler library

The design of nozzle library on this silk material replacement device is shown in Fig.4. The nozzle library consists of a nozzle connecting plate, a nozzle hanging plate and an extruder nozzle mounted with two or more types of color silk material. One end of the nozzle connecting plate is connected with the outer frame of the printer and the other end is fixed with a nozzle hanging plate. The nozzle hanging plate has three nozzle hooks distributed in a triangle way, which turn into spare extruder nozzles and hang in the outer frame of the printer in single shape after cooperation between the trapezoidal hole and the hook on the L-shaped plate of the nozzle.

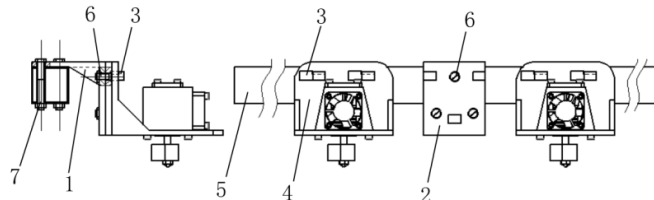

1 Nozzle connecting plate ; 2 Nozzle hanging plate; 3 Nozzle hook; 4 L-shaped plate; 5 Axle of outer frame 6 Countersunk bolt 7 Nozzle connecting plate bolt

Fig.4. Structure chart of nozzle library

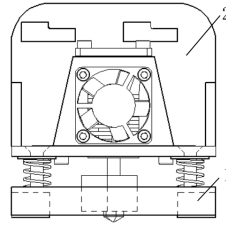

1 Nozzle fixing plate; 2 Extruder nozzle

Fig.5. Combined extruder nozzle

The principle of automatic color silk material replacement

The automatic replacement of color silk material is achieved by combining and detaching the two parts of the spliced print head. The nozzle fixing plate is an active moving part in the silk material replacement device, and can be moved to any position in the working space under the guidance of the stepping motor. The countersunk screws on the nozzle fixing plate enter from the gourd hole and stop at the small hole. By this time, the cylindrical coil spring is compressed to provide an elastic force, but the diameter of the head of countersunk screws is larger than that of the gourd hole, and under the force of elasticity, the countersunk screws are just inserted into the chamfer of the upper part of the hole. The holding space of elastic locking positioning is formed between two parts, then they splice into a whole. Detachment is an inverse process of combination. The extruder nozzle after being spliced is shown in Fig. 5.

Conclusion

By researching the development situation of 3D printers based on FDM technology at home and abroad, this paper finds a weak zone of current 3D printers based on FDM technology, proposes the design scheme of color 3D printers based on FDM technology, does the overall design of mechanical structure of the entire color 3D printer, makes improvements in the print head of 3D printers and designs silk material replacement device key to achieving color 3D printing.

Acknowledgements

This work was financially supported by the Hunan Provincial Science and Technology Department of key projects funded projects (2015NK3).

References

- [1] Li Xiaoli, Ma Jianxiong, Li Ping. *3D printing technology and application trends* [J]. Automation Instrumentation, 2014, 3(01):1-5.
- [2] Tang Tongming, Zhang Zhen, Deng Jiawen. *Research Status and Development Trend of 3D Printing Technology Based on FDM* [J]. New Materials for Chemical Engineering, 2015,06:228-230.
- [3] Jaina Pranjali, Kutheb A M. [J]. *Procedia Engineering*, 2013,63:4-11
- [4] Information on <http://www.wohlersassociates.com>.
- [5] Yu Hao. "Made in China 2025" under the 3D printing [J]. New materials industry, 2015,07:20-27.
- [6] Wang Xueying. *3D printing technology and industry development and prospects analysis* [J]. China's high-tech enterprises, 2012,26:3-5.
- [7] Brian Evans. *Analysis of 3D printers* [M]. Machinery Industry Press.2013.
- [8] Lee Weichen, Wei Chingchih. *Journal of Materials Processing Technology* [J], 2014,214(11): 2366-2374
- [9] Dietmar W. Hutmacher. *Mechanical properties and cell cultural response of polycaprolactone scaffolds designed and fabricated via fused deposition modeling* [J]. HUTMACHER ET AL, 2000.