

Design of Portable formaldehyde detector

Fu Li^{1,a,*}, Fu Xiuwei^{2,b} and Zhang tianhao^{3,c}

¹ College of Information & Control Engineering, Jilin Institute of Chemical Technology, Jilin 132022, China

² College of Information & Control Engineering, Jilin Institute of Chemical Technology, Jilin 132022, China

³ College of Information & Control Engineering, Jilin Institute of Chemical Technology, Jilin 132022, China

^afuli247012412@126.com, ^bfxw7720268@163.com, ^c2686198378@qq.com

*Corresponding author

Keywords: Electrochemical sensor, SCM, Formaldehyde.

Abstract. In this paper, a portable formaldehyde detector based on electrochemical sensor and single chip microcomputer is designed. During the detection, the gas containing formaldehyde diffuses into the sensor, reacts with the inner electrolyte and produces a weak current signal, which is converted into a voltage signal by the working circuit. The voltage signal is then input to A/D through the signal processing circuit, and the MCU is collected through A/D, and the signal is processed, and the operator is communicated through the key and LCD.

1. Introduction

Formaldehyde (HCHO), the English name is formaldehyde, is a kind of raw poison, can be combined with protein, inhaling high concentration of formaldehyde, there will be severe irritation and edema of the respiratory tract, eye pain, headache, and also can occur bronchial asthma. Formaldehyde vapor can strongly stimulate mucosal, carcinogenic, is a great harm to human body high toxicity. In recent years, because of the improvement of the people's living standard, buying new houses and new houses has become the first choice after people's life is rich. In the synthetic panels used for indoor decoration, formaldehyde is used as a glue and preservative, and the residual and non participating formaldehyde in the plate is released to the surrounding environment, which is the main source of formaldehyde in indoor air. Under the background that all kinds of diseases caused by indoor formaldehyde exceed the standard greatly, this paper combines the existing formaldehyde detection method and the formaldehyde detection device in the market, designs a kind of portable based on electrochemical sensor and single chip microcomputer. Low power consumption, high cost-performance, and other characteristics of formaldehyde are detected.

2. Realization of formaldehyde detection in air

2.1 Selection of detection methods

At present, there are a variety of formaldehyde detectors in the market, among which the more common one is the photoelectric photometry of test paper, that is, when formaldehyde gas is blown onto the test paper impregnated with chromomeric agent, In combination with tab impregnated with a chromomeric agent, the color changes as a result of a chemical reaction. When formaldehyde is in contact with the test paper, it reacts with formaldehyde to form a compound, which changes from white to yellow. The degree of discoloration can reflect the reflected light quantity of the light, and the intensity change rate of the reflected light can be used as the response value of the formaldehyde content of the measured gas. The concentration of formaldehyde gas can be measured by measuring

the reaction rate by setting the detection line in advance. In gas acquisition, some use automatic suction type (including micro gas pump, some use diffusion type).

For the determination of formaldehyde concentration by photoelectric spectrophotometer, it has the advantages of high sensitivity, simple operation and fast determination. The visual colorimetric method is often used in the analysis of formaldehyde concentration, and its disadvantages are as follows:

(1) Because many colored solutions are not stable and cannot last for long, it is often necessary to prepare solution at the same time of determination, which is more time-consuming and time-consuming.

(2) The accuracy of visual colorimetry is low, and the relative error is $\pm 5\%$ 20%.

The sensor detection method is used in this design. The type of sensor used is electrochemical sensor. It can convert the concentration of formaldehyde into a weak current signal. Thus, the weak current signal can be converted into a stable voltage signal which can be measured by the current voltage conversion circuit, and the stability of the electric signal is enhanced.

2.2 Working principle and Model selection of Electrochemical formaldehyde Sensor

The electrochemical sensor we use belongs to the constant potential electrolysis type sensor.

The sensor can be equivalent to a number of capacitors, resistors, this equivalent capacitance, resistance is randomly varying. The basic principle of the electrolysis sensor is to control a certain potential through the external circuit to make the substance under measurement redox reaction on the working electrode. The current produced by the reaction is in direct proportion to the concentration of the measured substance.

After analyzing the demand of the design and several kinds of electrochemical sensors available in the market, the CH₂O sensor of Membraprr Company of Switzerland is adopted in this design.

3. Design of formaldehyde detector

3.1 Overall design of formaldehyde detector

The overall structure of the system is shown in Fig. 1.

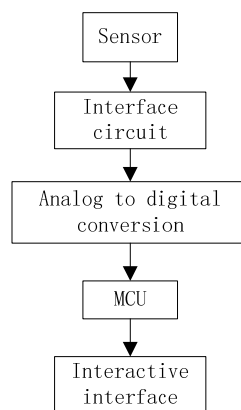

Fig. 1. System overall structure diagram

3.2 Sensor interface design

The signal output from the sensor is a weak current signal. If the signal is not processed properly, the interference signal will easily sneak in, which will also affect the stability and accuracy of the system. In order to avoid the disturbance of the external interference signal during the weak signal transmission, the interface circuit of the sensor should include the constant electric displacement circuit and the reference voltage circuit. Fig. 2 shows the electrochemical sensor interface circuit.

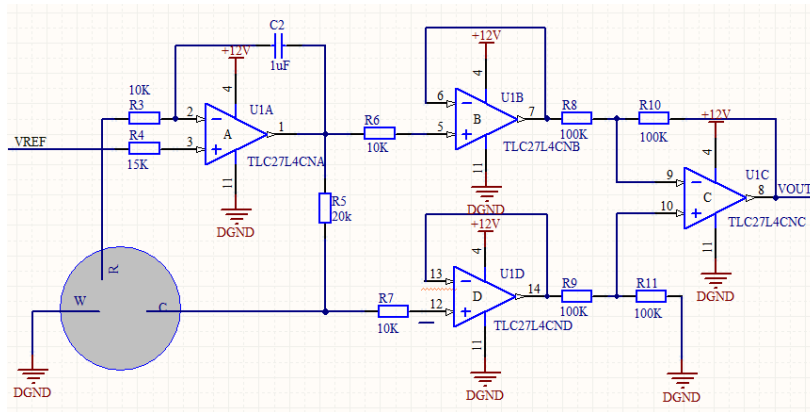

Fig. 2. Electrochemical sensor interface circuit

As shown in Fig. 3. is the reference voltage supply circuit: where the reference voltage value is generated by the lm385-1.2, the reference voltage V_{ref} 1.235 v.

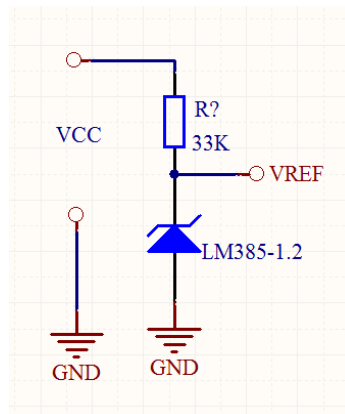

Fig. 3. Reference voltage circuit

3.3 Signal processing circuit

The voltage signal output by the interface circuit of the sensor, first of all, is small and needs further amplification. Secondly, because of the temperature drift of the electrochemical sensor, the output value of the signal is not very stable. To compensate for this shortcoming, hardware can be adjusted, as shown in Fig. 4.

In this design, the hardware circuit designs a circuit that can adjust the working zero and the magnification. The V_{out2} output of the amplified signal enters A/D to realize the analog-to-digital conversion, and the digital signal is output to the single-chip microcomputer STC89C51. The function is realized by software. The single chip microcomputer in this design adopts STC89C51RD, A/D conversion module using 10 bit TLC1549. The specific circuit is shown in Fig. 5.

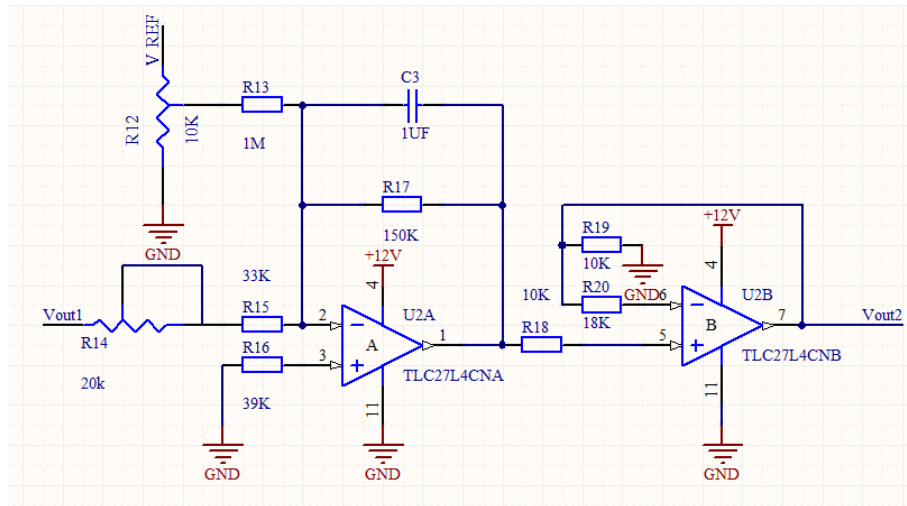

Fig. 4. Signal processing circuit

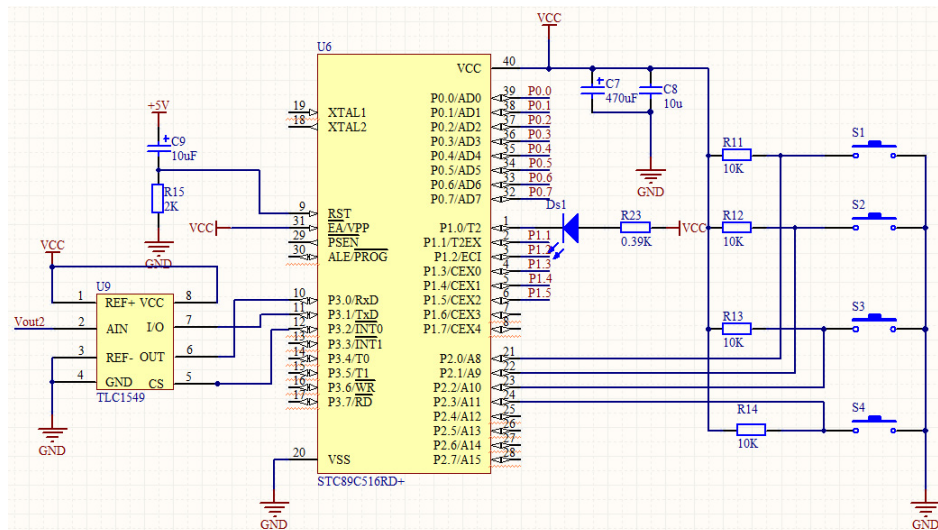

Fig. 5. Microcontroller peripheral circuit

4. Conclusion

In this paper, the design is unique: because of the simple hardware circuit, the power consumption of the system is greatly reduced by the application of FLASH on MCU chip. Firstly, the electrochemical sensor is used in this design, which has the characteristics of high sensitivity, good accuracy and small volume, so it is very suitable for portable products.

References

- [1] Zhu Lifang. Summary of methods for determination of formaldehyde in Air [J]. Environmental pollution and prevention, 1991,13(3):33-36.
- [2] Du Juan. Design of portable field formaldehyde detector [D].Master's thesis. Zhengzhou: Zhengzhou University, 2010:28-32.
- [3] He Limin. MCS 51 series single-chip microcomputer application system design [m]. Beijing University of Aeronautics and Astronautics Press, 1990.
- [4] Allen, J. Bard, Larry, Faulkner, Shao Yuanhua, et al., Principles and Applications of Electrochemical Methods. Chemical Industry Press, 2005.

- [5] PopovA, SherstnevV, YakovlevY, etal. Application of AntimonideLaser toHCHOMeasurements at 3.55 μm [J].VDI-Ber,1998,1336:173-176.