

Study of synthesis optimization of a marine power station

Sun Ming^{1, a}

¹Qingdao Ocean Shipping Mariners College, Qingdao 266071, China

^asunming@coscoqmc.com.cn

Keywords: ship, EEDI, synthesis optimization, marine power station, hardware-in-the-loop

Abstract. Recent developments of EEDI (energy efficiency design index) which is an indicator of ship's energy efficiency level imposed the cost effectiveness of sea-going vessels. Optimization of the ship's total energy system is studied in this paper. This study is focus on optimum load sharing control, which control function is intended to operate the exhaust-gas turbo-generator (TG) and shaft-driven generator (SG) at its maximum efficiency, thereby reducing the total operation hours and maintenance costs of the diesel generator (DG) that back up TG and SG. The complete optimization problem has been solved using the hardware-in-the-loop system.

Introduction

The recent EEDI is put forward by IMO and demonstrates ship's energy efficiency with the ratio of CO₂ emission to freight capacity[1]. Optimization methodologies have been widely used for the design of ship based systems in the energy production[2]. However, there are only a few optimization studies regarding marine power stations. An attractive option for these ships is the integrated energy system, which consists of electricity producing units, such as the diesel generator (DG), the shaft-driven generator (SG) and the exhaust-gas turbo-generator (TG). This configuration has several benefits in terms of efficiency, compared with the independent generating sets, in particular, is of increased interest recently due to their high total efficiency[3].

An optimum load sharing control of synthesis energy system of sea-going vessels is investigated in this study. This control function is intended to operate the exhaust-gas turbo-generator (TG) and shaft-driven generator (SG) at its maximum efficiency, thereby reducing the total operation hours and maintenance costs of the diesel generator (DG) that back up TG and SG. When TG, SG and DG are on line, this function controls them so that TG or SG will be optimally loaded to the conventional rated output value, and DG will never be loaded below a predetermined low load limit[4].

The optimum load sharing control as mentioned above is achieved through monitoring the load on each generator on line, computing the load to be share by each generator on line, and controlling the governor motor of each generator engine according to the computed load share. Results have indicated the optimization methods for the design of synthesis marine power stations[2-5].

Description of the marine power station

The synthesis optimization of marine power station is considered, it is graphically depicted in Fig.1. The shaft generator system of static frequency converter type introduced here, which includes a thyristor inverter, converter the output of the generator coupled with the main engine, once to direct current and then to alternating current at a constant frequency[6]. Thus, a constant frequency can be obtained regardless of the rotational variations of the main engine, and so the range of rotation which can be used is widened and also parallel running performed between SG-TG or SG-DG. The shaft generator shall be driven by the main engine. The range of rotational variation of the main engine in which the bus output can be at a constant frequency is from 58.1rpm to 83 rpm, the output is at the rated value.

In Fig.1, The CONV. (converter) used to convert the AC output of the shaft generator with frequency variations once to direct current, which has no relation to the frequency, and composed with 6 thyristor arms. The trigger pulse system gives a delay angle $\alpha \approx 20^\circ \sim 25^\circ$. In case the trigger

pulse system gives a delay angle $\alpha \approx 140^\circ$ by gate shift, the current will be cut off instantaneously. The INV. (inverter) also composed with 6 thyristor arms. The trigger pulse system gives a delay angle $\alpha \approx 140^\circ \sim 150^\circ$ (or $\beta \approx 40^\circ \sim 30^\circ$).

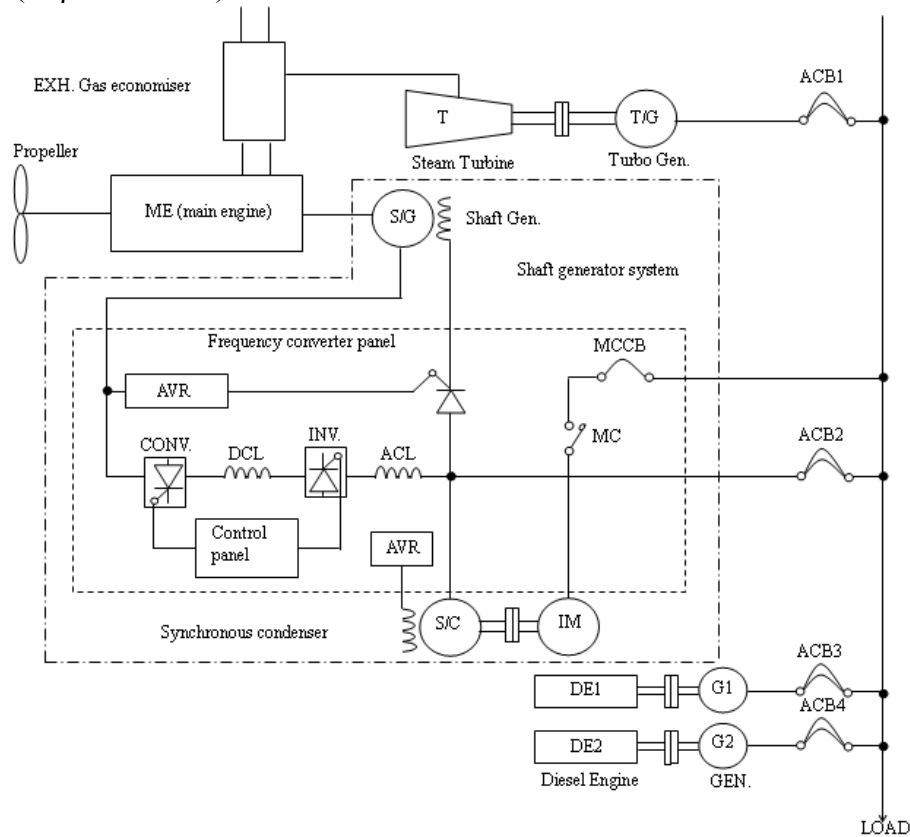

Fig.1 The synthesis marine power station

Bus frequency is performed by changing frequency (revolution) of SC (synchronous condenser) by means of phase control of thyristor converter. When the load increases and the active power of the bus increases, or when the rotational speed of the shaft generator drops and the output decreases, the frequency of the bus will decrease if the active power output from the converter is not matched with the effective power of the bus by some method, or in the reverse case, the bus frequency will increase. Therefore, in this system, the method used for this purposes involves detection of the bus frequency using PID controller with current minor loop, and phase control of the thyristor inverter in such a manner that the detected bus frequency reaches a set value. Thus, a constant frequency is obtained.

DCL (DC reactor) is used for stable inverter operation by smooth out pulsations of the direct current. ACL (AC reactor) is used for improving the AC waveform. Reactive power is necessary for operation of the inverter itself. Therefore, a synchronous condenser (SC) is provided as a source of the required reactive power. This SC is coupled with a starting motor and the SC is driven by the starting motor using the bus as the power supply. When starting motor speed increases over 95% of SC rated speed, power supply for starting motor will turn off, then SC will be operated by the inverter.

Function of the marine power station

Number of diesel generators on line control function, which controls the number of diesel generators on line in response to changes in the ship's power demand, is intended to ensure a higher degree of "continuity of service" through minimizing operations of the preference tripping system and generator overload protection and also to operate the diesel generators within their high fuel-efficiency region. This function is shown in Fig.2. In Fig.2, k_1 is start request point, k_2 is stop request point. k_1 and k_2 are mathematical symbols used for explanation purposes only. In setting them, k_1 should be greater in value than k_2 . $k_1 = (85 \sim 90)\%$ and $k_2 = (75 \sim 80)\%$; k_1 time is 30 seconds and k_2 time is 1800 seconds. N is number of generators on line, P_{1N} is stand-by start request point (%),

P_{2N} is stop request point in expected loading percentage after generators removal, P_{3N} is actual loading percentage before generator removal at P_{2N} point. $k_7=0 \sim 50\%$, $k_6=30 \sim 50\%$, $k_5=k_1/2$, $k_4=(k_2+k_6)/2$, $k_3=k_1-k_6$.

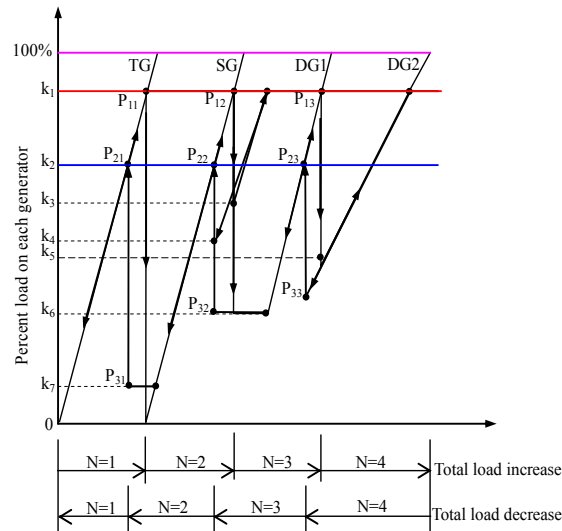

Fig.2 Diagram to show number of generators on line control

This start request point k_1 (%) is mathematically expressed as:

$$k_1 = \left(\frac{\sum_{n=1}^N P_{Ln}}{\sum_{n=1}^N P_{Rn}} \right) \times 100 [\%] \quad (1)$$

This stop request point k_2 (%) is mathematically expressed as:

$$k_2 = \left(\frac{\sum_{n=1}^N P_{Ln}}{\sum_{n=1}^N P_n - P_R} \right) \times 100 [\%] \quad (2)$$

Where P_{Ln} is load on generator all generator in kW, P_{Rn} is rated output of all generator in kW, P_R is rated output of first stopping generator in kW.

In Fig.2, assume the total kW load is increasing. When the loading percentage of the diesel generator or generators on line reaches k_1 (%) and this condition exists for the time length set by the k_1 timer, an automatic start command signal is produced. In response to this signal, the stand-by generator is automatically started, synchronized and put on line for parallel operation with the generators already on line.

If the total kW load decreases to such a degree that the removal of the 1st stopping generator will not result in loading percentage more than k_2 (%) for each diesel generator remaining on line, and this condition exists for the time length set by the k_2 timer, an automatic stop command signal is produced. In response to this signal, load on the 1st stopping generator is shifted to be the other generators on line, then the ACB of the first stopping generator is tripped and its engine is automatically stopped (after a predetermined length of engine idling time when necessary).

Optimum load sharing control

TG/SG/DG conventional rated output for control purposes are 0~3000kW (10kW minimum setting unit), stand-by start request point is 90 to 100%, TG/SG low load limit is k_7 , DG low load limit is k_6 . The total kW load P_L is known as the sum of kW loads on generators on line. The following describes the operation under TG/SG/DG Specified in Fig.2.

TG is in single operation and load on it increases. When load on TG reaches P_{TG-H} (Stand-by start request point P_{11}) and this condition exists for a predetermined length of time, an automatic start command signal is given to a stand-by SG. In response to this signal, SG is automatically started, synchronized and put on line for parallel operation with TG. TG is loaded to its P_{TG-O} (conventional rated output of TG in kW), while the rest of load is shared-by SG. When load on SG reaches P_{SG-H} (Stand-by start request point P_{12}) and this condition exists for a predetermined length of time, an

automatic start command signal is given to a stand-by DG. DG is automatically started, synchronized and put on line for parallel operation with TG and SG. DG is loaded to its low load limit P_{DG-L} (low load limit of DG in kW, k_6 -set in % of DG'S rated output) constant, while the rest of load is shared-by SG. For control in this load zone, the target load share for each generator is computed as follows:

DG: DG rated output \times DG low load limit setting (P_{DG-L}) (kW);

SG: $P_L \sim P_{DG-L}$ (kW); TG: P_{TG-O} (kW).

If load on SG reaches P_{SG-O} (conventional rated output of SG in kW) with a further increase of P_L , DG low load limit control is canceled. Instead, SG is loaded to P_{SG-O} constant and DG shares the rest of load. For control in this load zone, the target load share for each generator is computed as follows:

DG: $P_L - P_{SG-O} - P_{TG-O}$ (kW), provided $P_L > (P_{DG-L} + P_{SG-O} + P_{TG-O})$; TG: P_{TG-O} ; SG: P_{SG-O} .

When more than one DG are available as stand-bys, the optimum function controls the number of DGs on line to cover changes in P_L . DGs are controlled in a proportional load –sharing mode.

If a decrease of the total load P_L results in a reduction of load on DG to its low load limit P_{DG-L} , TG and SG optimum load sharing control is canceled. Instead, DG is load to P_{DG-L} constant and SG shares the rest of load. Therefore, the target load share of each generator is as above mentioned. This is to prevent the reverse power flow into DG. If the load on SG is reached to its low load limit P_{SG-L} as a result of a further decrease of P_L , DG low load limit control is canceled, this condition exists for a predetermined length of time, DG is stopped. Instead, TG is loaded to P_{TG-O} constant and SG shares the rest of load. If the load on SG in percent of its rated output becomes equal to the TG low load limit setting with a still further decrease of P_L , SG low load limit control is canceled, this condition exists for a predetermined length of time, SG is stopped.

In the other example of optimum load sharing control, the last diesel generator remaining on line is intentionally not removed. Instead, TG and DG are controlled in a proportional load-sharing mode with P_{TG-R} being the rated output capacity of TG. This is to prevent the reverse power flow into DG.

Experiments and results

The hardware-in-the-loop (HIL) is an environment where virtual components work in conjunction with real system's components. It is mainly employed to test a real control system on a virtual plant in order to verify its performance before applying it to the real plant[7, 8]. In this research, optimum load sharing control functions are used to design appropriate simulation environment under frequency conversion motors driving synchronous generators. The on-line control is performed using the HIL concept. The HIL is shown in Fig.3. The HIL is used for testing hardware controllers on software models, in this research, software components are used to optimize load sharing control [9]. The strategy adopted in this research was divided into three successive stages: on-line testing, off-line controller design, and on-line optimum control. The results are shown in Fig.4.

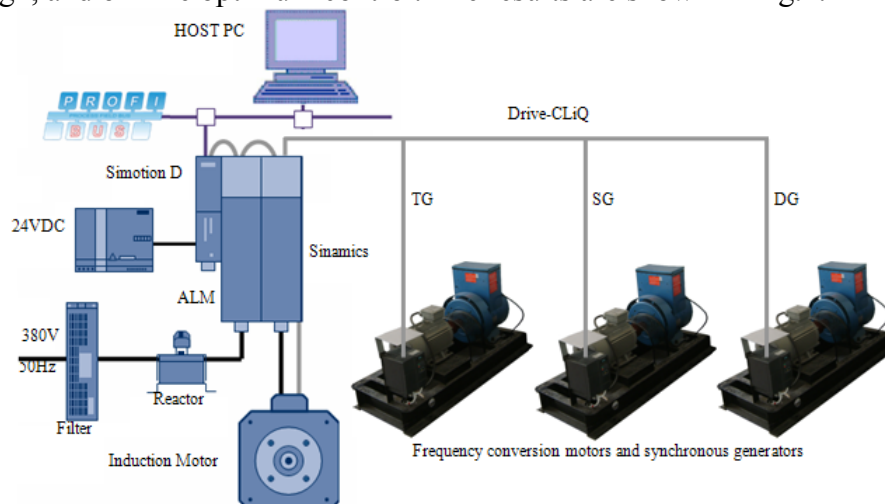

Fig.3 Optimum control experiment for marine energy based on HIL

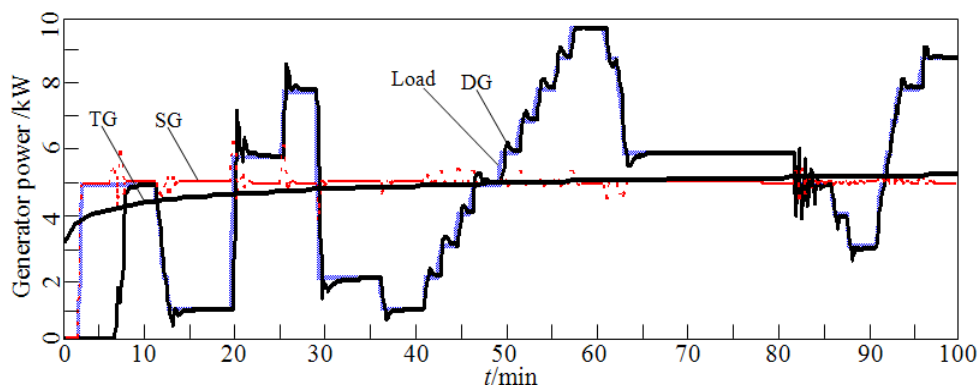

Fig.4 Load response to TG, SG and DG based on HIL

In Fig.3, HIL of TG/SG/DG conventional rated output for control purposes are 5kW, 5kW and 10kW, respectively. In Fig.4, TG is in single operation and load on it increases at first. After 2.6 min, SG is automatically started, synchronized and put on line for parallel with TG. About 10 min, DG is automatically started, synchronized and put on line for parallel with TG and SG. TG and SG are loaded to its P_{TG-O} and P_{SG-O} , they share the constant load, while the rest of variable load is shared-by DG.

Conclusion

A methodology for the synthesis optimization of marine power station has been presented in this study, a strategy to optimize and control a marine power station is provided. TG/SG/DG has been selected as an application example. A general control of the marine power station has been developed and an optimum load sharing control has been applied for the solution of the maximum efficiency problem. Optimization results using frequency conversion motors, synchronous generators and Siemens SCOUT software were carried out. The virtual controller was applied to the marine power station system via HIL environment, results showed that the proposed strategy was able to optimize and control the marine power station.

Acknowledgments:

This work was supported by COSCO Research Project under Grant Nos.2010-1-H-002.

References

- [1] Y. L. Liu: submitted to Shipbuilding of China (2009)
- [2] G. G .Dimopoulos, A. V. Kougioufas and C. A. Frangopoulos: submitted to Energy (2008)
- [3] G. C. Zhang and J. Ma, J: submitted to Harbin Institute of Technology (2011)
- [4] G. C. Zhang and J. Ma: submitted to Journal of Shenyang University of Technology (2011)
- [5] X. P. Jia, F. Wang, S. G. Xiang: submitted to Resources, Conservation and Recycling (2008)
- [6] G. C. Zhang, in: *Modern Marine Power Station*, edited Z. J. Yang/Dalian Maritime University Publishing, China (2012), in press.
- [7] T. Ericson and Y. Khersonsky: submitted to IEEE Transactions on Industry Applications (2006)
- [8] C, T. Raj, S. P. Srivastava and P. Agarwal: submitted to International Journal of Computer and Electrical Engineering (2009)
- [9] A. Saleem, R. Issa and T, Tutunji: submitted to Simulation Modelling Practice and Theory (2010)