

# Design and Implementation of the Computer Monitoring and Management System for the Multi-mode Combination Timer Device

Pengfei Wu, Jianxun Li, Yujian Wang

Faculty of Automation and Information Engineering  
Xi'an University of Technology  
Xi'an 710048, China  
E-mail: wupengf@xaut.edu.cn

Jianxun Li

State Key Laboratory of Transient Optics and Photonics  
Xi'an Institute of Optics and Precision Mechanics of CAS  
Xi'an 710119, China  
E-mail: Ljx088@xaut.edu.cn

**Abstract:** The multi-mode combination timer device can receive the GPS/GLONASS, No.1 BeiDou and loran-C at the same time. Since the multiple external frequency sources are introduced for the system, it is necessary to manage and monitor it. The wavelet decomposition atomic time algorithm is used to weight average the external reference signals in the wavelet domain, and the integrated time scales are obtained. The disciplined clock technology is employed to the time scale for calibrating the clock; the results indicate that the system can achieve fast timing and the complementary advantages of all kinds of resources.

**Key words:** Multi-mode combination; Computer Monitor; Wavelet Decomposition; Time Scale Alignment

## I. INTRODUCTION

Time is a basic physical quantity that can offer time benchmark for all the dynamics expansion process. With the development of modern science and technology, synchronization precision of time frequency is put forward higher request. Since the time synchronization equipment is used as the core of the synchronous system, its characteristics directly decide the precision, reliability and security of the whole time synchronization network. Synchronization of time frequency is contacted with all kinds of synchronous equipments and the transmission of time frequency signals. Developing our own country's autonomous navigations time service system as the external time benchmark synchronization equipment can help reduce the dependence on GPS, improving reliability and security. At present, the research of synchronized timing equipment tends to the direction of independent, dual-mode or multi-mode, and some related products have been made. However, the benchmark sources of the equipments are used as main sources or the auxiliary. This resulted in the waste of resources. It is detrimental to improve the synchronization precision and it is easy to leave behind potential safety hazard in the important application fields. To solve these problems, this paper adopts the wavelet decomposition atomic time algorithm [1-6] and disciplined clock technology, and designs to achieve the computer monitoring system of the multi-mode combination timer device.

## II. GENERAL SCHEME

### A. Composition of multi-mode Combination timer Device

The multi-mode combination timer device uses basic design plans of Rb atomic clocks and many timing function modules, which mainly includes the GPS/GLONASS, No.1 BEIDOU and loran-C timer receiving module, Rb atomic clocks module, clock difference measuring module, wavelet atom processing module, 1PPS producing and phase adjusting module, time information processing module, Rb atomic clocks calibration module, monitoring module and timing function module, points frequency module etc. The system design principle block diagram is showed in figure 1.

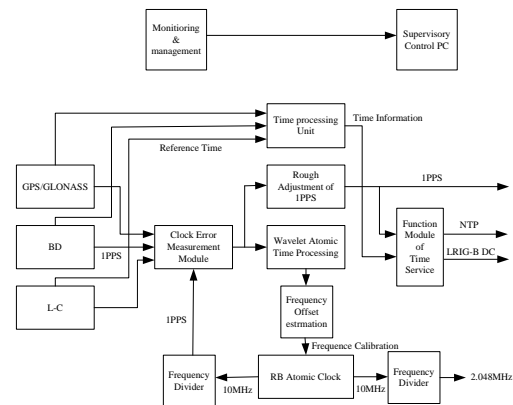

Fig1. Principle diagram of equipment

Three kinds of timer receiving modules are responsible for receiving timing signal of external reference benchmark source. After processing, they provide 1PPS signal, time and status information of RS232 format for the system. Rb atomic clocks module is keeping clock in the equipment. It provides standard 10MHz clock for the system. Clock difference measuring module is responsible for measuring 1PPS signal of equipment output and time difference of 1PPS signal of three kinds of external reference benchmark source. The results of the measurement are coupled back to

the processing unit. Time processing unit produce systematic time information and maintain systematic time information. After coding, it sends every timing function module to provide corresponding timing service. IPPS phase adjusting unit adjust real-time phase of equipment timing 1PPS signal, making the precise synchronization be synchronal to external reference source. Wavelet atom processing module uses the algorithm of wavelet decomposition atom to dispose measurement results of clock difference measuring unit, through the different scale of dynamic weighting which can achieve the advantage complementary of each reference source signal, getting high precise time scale. And the time scale of all kinds of noise is well restrained. According to the time scale which is produced by the wavelet atom processing module, Rb atomic clocks calibration module estimates the relative frequency deviation of the punctual Rb atomic clocks and time scale, and adjusts the frequency of Rb atomic clocks.

**B. Monitoring management**

The equipment includes a monitoring management module which is responsible for exchanging data with monitoring software through monitoring interface which is connected to the monitoring computer, in order to obtain a variety of types of monitoring management for equipments. In addition, the whole equipment uses the modular design. Every relatively independent function module is realized by independent single circuit. It is in favor of taking advantage of the existing resources of every OEM board and developing and testing circuit boards which need independent research. At the same time it can attain characteristics of flexible configuration according to different applications, and product design is changed a little.

**C. Structure design of the monitoring system**

The multi-mode combination timer device has many internal modules, and the function is complex. It is a very crucial problem to monitor the running state of the internal modules .So this paper carries on the detailed design in the monitoring system of equipment, making the device have the function of computer monitoring .The monitoring system of the multi-mode combination timer device consists of three parts: monitoring computer 、 communication channel 、 multi-mode combination timer device. As a monitoring unit, Monitoring computer’s main function is to carry on centralized controlling and unified supervision in the multi-mode combination timer device. The units that are monitored include monitoring punctuality module, timing benchmark source module, NTP GPS clock module, IRIG-B GPS clock module and BITS module.

The operation of monitoring computer for multi-mode combination timer device has mainly four business, including parameter settings, status query, alarm processing, data collection storage. Each module of the multi-mode combination timer device is supervised. It not only need to passively response command coming from of the computer monitoring, but also must transfer the current fault information to the monitoring computer initiatively by the form of the warning command. Except BITS module which

is in the internal integrated of the monitoring time board, the communication way of monitoring computer and the multi-mode combination timer device, the internal communication way of the multi-mode combination timer device are via RS232 serial port connection. Monitoring computer 、 other modules are connected with the monitoring time board ,and by the monitoring time board achieving the interconnection between the monitoring computer and all modules. The structure of the monitoring system of the multi-mode combination timer device is showed in figure 2.

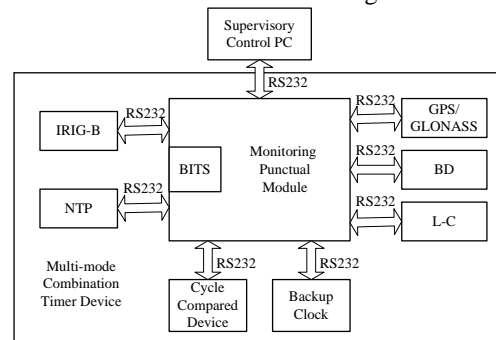

Fig2. Structure diagram of control system

**III. THE DESIGN OF THE MONITORING AGREEMENT**

Monitoring system of the multi-mode combination timer device involves all timer receiving OEM modules and timing function module of equipment in the equipment. In order to coordinate these modules with monitoring computer, it needs a unified agreement to restrain all modules in the monitoring system. Therefore, this paper designs monitoring agreement of the multi-mode combination timer device and rules the communication format of monitoring data 、 the operating authority of monitoring both sides、 the operation method and the monitoring interface technology, etc.

**A. The basic format of monitoring data**

The basic form of interactive communication of monitoring computer and the multi-mode combination timer device is command frame. A complete command frame is composed of starting marks unit 、 command unit、 XOR check unit and end sign unit, showed as table I. Starting marks unit is a starting mark of a complete command frame, which is fixed for ASCII character "\$"; End sign unit is an end sign of a complete command frame, which is fixed for ASCII character "<CR><LF>".

TABLE I. GENERAL FORMAT OF MONITORING INFORMATION INTERACTION APPLICATION FRAME

Initial identification unit	Command unit	Calibration unit	End mark unit
\$		*hh	<CR><LF>

The command unit of table I is composed of command control head and command body, and the composition format of the command unit is showed in the table II. Command control head includes equipment numbers 、

receipt ID、deliver ID、command sign、response marks and command body length six fields. It is altogether six byte length. Equipment numbers acquiesce in 00x00. Receipt ID and deliver ID are only signs of control module in the equipment. Command body length is refers to the actual bytes of command data. The analysis method and the actual length of command body are determined by command sign and command body length of control head part. The content of command body part is different for different modules.

TABLE II. COMPOSITION OF THE FORMAT FOR COMMAND UNIT

Command control head						Command object
Device number	Receiver ID	Sender ID	Command flag	Response flag	Command length	Command data
1 Byte	1 Byte	1 Byte	1 Byte	1 Byte	1 Byte	Variable length

The definition of the monitoring computer and the multi-mode combination timer device’s interactive command mark is showed as table III. Among them, the left side of the “flow object” indicates the initiative initiator of the command, and the right of the “flow object” indicates the passive response of the command. When passive response constructs response command, except the word of equipment numbers and command sign is the same as recently received command control head of command, other words of command control head are modified in accordance with the actual situation. The other command signs are reserved and monitoring agreement regards them as an illegal command sign.

TABLE III. COMMAND IDENTIFICATION FOR EQUIPMENT MONITORING

Command identification	Meaning	Flow direction	Remarks
P	Equipment parameter query	Monitor PC<—> Synchronization equipment	0x50
S	Equipment status query	Monitor PC<—> Synchronization equipment	0x53
C	Configuration parameters	Monitor PC<—> Synchronization equipment	0x43
A	Active alarm equipment	Synchronization equipment <—> —>Monitor PC	0x41
D	Data collection	Synchronization equipment <—> —>Monitor PC	0x44

The definition of response marks in the table II is showed on the table IV. As the initiative initiator of a command, 0 is written in the field. Passive response doesn't analyze and process for this field. If it is a response command, the field is a response mark. If the word is not 0, it indicates that recently received orders cannot be handled or are wrong. When initiator receives response that the response mark is not 0, it doesn't analyze and handle for command body. When the response mark becomes 0, “command body length” and “command body” are meaningful.

TABLE IV. ENCODING DEFINITIONS FOR RESPONSE SIGNAL

Code<ASCII>	Meaning	Remarks
0	Success	0x30
1	Check error	0x31
2	Command error	0x32
3	Sender ID error	0x33
4	Other errors	0x34

Calibration unit ensures the reliability of the data transmission. According to command unit of data frames, calibration unit create the XOR checksum, and both sending and receiving sides should handle date with XOR check. According to the command unit, sending side has to create the XOR checksum of 2 byte length; as well, when receiving side receives complete data frames, according to the command unit, it creates the new XOR checksum. If the new XOR checksum is equal with the received XOR checksum, it indicates the data frame is effective; otherwise, response frame of calibration error is sent to sending side.

*B. Requirement of the data transmission*

Monitoring data is transmitted by ASCII mode. Considering the problem that part of the invisible characters can not be transmitted and in order to avoid the conflicts between the no ASCII Code fields with the reserved characters, the no ASCII characters use split rule of 2 bytes in this agreement. The specific process is the hexadecimal number of 8 bytes is divided into high 4bits and low 4bits. As to high 4bits and low 4bits, if the figure is 0x00-0x09, it adds 0x30. If the figure is 0x0A-0x0F, it adds 0x37, and then the result is transformed to ASCII code. Split rule of 2 bytes is applied to all characters, except the sign unit of beginning and ending and the characters defined as ASCII characters.

Command unit always contains multi byte fields, such as clock correction date、frequency deviation、IP address and so on. In order to ensure the correct analysis of multi byte fields, the order of the byte stream of the multi byte fields is defined as: low byte first, high byte after. For example, the value of clock correction date is 0x1234 and clock correction date of 2 byte are ordered 0x34, 0x12. Multi byte stream of ASCII code format is not inverted.

*C. Agreement standard of data communication*

Communication protocol of equipment monitoring data uses UART agreement and full-duplex communication mode. UART uses ASCII code to send. When it sends 1 Byte character every time, the lowest order starts to transmit. The article uses UART frame, and the data bit is 8 bit. The start bit is 1bit, and the stop bit is 1 bit, while it dose not have a parity check bit.

*D. Standards of monitoring interface*

The physical layer interface standard of this agreement uses standard interface of RS-231CRS-231C, and connecting mode is simplified. According to standard of RS-231-C, when communication rate is under 20kb/s, the biggest physical distance that the RS-231C directly connected with is 15m. All serial ports can use the connection of 3 wires, which include sending data TXD、Receiving data RXD and Signal ground GND.

*E. Transmission of monitoring data*

By monitoring system structure chart, monitoring computer is connected to monitoring punctuality board. The date of every monitoring board can accomplish the monitoring software’s operation of each module by being transmitted by monitoring punctuality board. So monitoring

punctuality board is a hub of monitoring data transmitting. On one hand, the command of monitoring computer is transmitted precisely to corresponding modules, on the other hand, the dates of every module is transmitted precisely to monitoring computer. It involves the following questions. First, due to all monitoring interfaces are RS232 serial port, it must solve problems about many serial port communication. Second, all of the modules have two-way data transmission with monitoring computer, but serial port which is connected to monitoring computer has only one. So it must solve the problem of bus multiplexing. Third, because monitoring data needs to transmit between ARM chip and FPGA chip, it must solve the problem of transmitting data between two chips.

For the first problem, the article takes advantage of the strong expansibility of FPGA and rich IO serial port, creating some RS232 transceiver units. All monitoring module are realized by an independent module in the FPGA internal. These modules can store monitoring command. It can also send and receive monitoring command. There are connections among these modules and each module which is responsible for transmitting data to ARM in the FPGA internal. Through interrupt signal and chip select signal, these modules achieve the function of time division multiplexing of FPGA and the ARM communication interface. For the second problem, the article takes advantage of the mechanism of interrupt and priority to bus arbitration to avoid bus conflicts caused by multiple modules' competition for bus use rights. When bus is requested, according to priority from high to low, it starts to search. The highest priority module obtains bus right, until the data is transferred. Other modules can not break off data transmission process of a module.

In order to solve the problem of data transmission between ARM and FPGA, and not occupy too much processing time of ARM, the article uses the interrupt mechanism and it completes data transmission function between them by parallel bus way. Interface of FPGA and ARM uses communication mode of date line、 address line、 interrupt line and chip select line. In the FPGA a two-port ARM is structured, then FPGA is mapped in the BANK4 of ARM, and ARM can read and write FPGA, which likes to operate external memory. Data interaction is achieved between ARM and FPGA. Communication module structure chart of ARM and FPGA is shown in the figure 3.

Communication modules of ARM and FPGA mainly contain four units: interface reuse unit、 two port ARM、 ARM interface unit and FPGA interface unit. Interface multiplexing unit is responsible for interface multiplexing of all monitoring modules. ARM interface unit is responsible for sequential control of interface signal, when it communicates with ARM chips. Through reading and writing of double ports ARM completes ARM chips of FPGA chip reading and writing operation. FPGA interface unit is responsible for the input data of interface reuse unit which is deposited in the two ports ARM, inform ARM to read and send the data which ARM deposits in the two ports ARM to corresponding modules. Two ports ARM is a public

storage area of ARM interface unit and FPGA interface unit, and it stores monitoring data from the monitoring computer and each module.

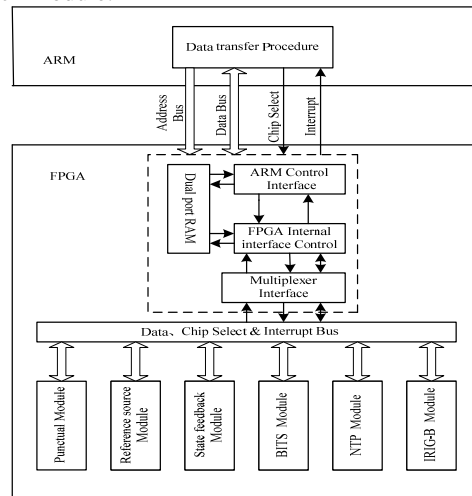

Fig3. Structure diagram of ARM and FPGA Communication module

#### IV. MONITORING SOFTWARE

For the convenience of customers to conduct monitoring operation to the multi-mode combination timer device, the computer monitoring software needs to be real-time, effective and reliable to conduct management, maintenance and control of the device. Computer monitoring software runs on Windows environment. It uses object-oriented C++ language design, has an intuitive, friendly man-machine interface, provides users with the curve, graphics, data of visual display, and makes all kinds of data query operation simply and easily. At the same time, computer monitoring software also has real time and expansibility and maintainability. The computer monitoring software of the multi-mode combination timer device is linked together with device by RS232 serial port. By interactive communication of monitoring command to complete the following functions:

- a) State query: The user can update the queries for the real-time operation state of each module manually and updated state is showed by visual graphics or data in the corresponding position.
- b) Parameter query: when a module has not only a work mode, the user can use query operation to get the real-time working parameters of the internal module of the equipment.
- c) Parameter configuration: the user can conduct online configuration through the monitoring software for the working parameter of internal certain module of the device.
- d) Warning display: Each module of the device appears all kinds of fault in the running process, and it will warn initiatively to monitoring software .After monitoring software receives the warning information, it will show the warning information to the users by the intuitive way.

e) Data storage: monitoring software can automatically collect and store data from the multi-mode combination timer device, such as the clock correction data and so on. Data is stored in a database, which provides possibility for further data processing and analysis.

Monitoring software manages the internal multiple module of the device at the same time. Because the monitoring contents can not be showed in the same interface, using the paging way to display, users can call out the specific control interface of the module by clicking the menu of the corresponding module on the interface. The interface of monitoring software displays the warning information of each module; more detailed information and operation function are displayed and carried out in the interface of their respective module.

#### V. EPILOGUES

The multi-mode combination timer device uses a variety of frequency signal of external time. We can use the monitoring system to manage this information and analyze the historical data, ensuring the normal operation of the equipment.

#### ACKNOWLEDGMENT

One of us thanks the support of Science and Technology Project of Xi'an(CX1252©) and Research Project of Xi'an University of Technology(105-211023) and Education Office Foundation of Shaanxi Province(2010JK724).

#### REFERENCES

- [1] X.Z.Ke,X.H.Li,Z.Y.Liu.The Frequency Stability of the Wavelet Decomposition Algorithm. *Acta metrologica sinica*,2002,23(3):205-210.
- [2] X.Z.Ke,X.H.Li,Z.Y.Liu.Stability analysis of a time scale algorithm. *Acta Astronomical Sinica*,2001,42(4):420-426.
- [3] X.Z.Ke,Z.S.Wu.Multi-Resolution Synthesis of Time Scale. *Acta electronic Sinica*,1999,27(7):135-137.
- [4] X.Z.Ke,Z.Y.Yin.Distributed atomic time scale in Beidou/Loran-C integrated navigation system and experimentresearch. *Chinese Journal of Scientific Instrument*,007,28(10):1764-1769.
- [5] X.Z.Ke.Multi mode timing system and timing method based on wavelet transform; China, CN201010136970.6[p].2010,8,11
- [6] X.Z.Ke,K.Y.He,H.B.Yuan.Study of synchronizing accuracy in telephone time system .*Journal of Astronautic Metrology and Measurement*,2000,(1):27-31
- [7] X.Z.Ke,K.Y.He,H.B.Yuan.Computer network time services and frequency measurement system [J]. *Journal of Astronautic Metrology and Measurement*,1999,(4):1-5