

The Analysis of Transient Grounding Resistance of Portable Horizontal Grid Earth Electrodes

Qu Xinbo^{1,2}, Zhou Bihua¹, Cao Ningsheng², Fu Yapeng¹, Huang Xiaogang¹

(1. National Key Laboratory on Electromagnetic Environmental Effects and Electro-optical Engineering, PLA Univ. of Sci. & Tech., Nanjing 210007, China, quxbo@163.com;

2. Nanjing Telecommunication Technology Research Institute of CESEC, Nanjing, China)

Abstract —Based on current situation of mobile equipments' earth devices, a new type of portable horizontal grid earth electrode has been designed. With the impulse ground measurement system, different number of earth electrodes' responses to double exponential pulse current have been tested on cement grounds. Impulse waves of voltage and current have been gotten by experiments, and the curve of Transient Grounding Resistance(TGR) can be calculated. The analysis of discharging capacity of horizontal grid earth electrodes in time domain has great significance in the design of mobile equipments' earth devices.

Index Terms Portable; Horizontal grid earth electrode; Transient grounding resistance

I. INTRODUCTION

With the development of electronic technology, the information equipments which are highly integrated become more and more sensitive. In recent years, the accidents and hazard areas of equipments and systems damaged by Electromagnetic Pulse(EMP) effect increased largely. So it has great significance to study the grounding's pulse response under pulsed discharging current in the design of protection against electromagnetic pulse^[1].

In common electrical safety measures, earth device is one of those most widely used^[2]. When impulse current is discharged, TGR not only relates to the earth resistivity and situation where the earth electrodes lie, but also are affected closely by their shapes, sizes, arrangements and so on^[3].

The research of TGR becomes one of the most hot researches of electromagnetic protection. In [4], the character of the earth devices of transmission tower has been analyzed and a new method of testing TGR with impulse current signals is brought up. In [5], a new fast algorithm aiming at the transient current distribution of the building lightning protection system is presented. And in [6][7], the earth net of substation has been studied on the numerical methods for electromagnetic fields in frequency domain and application. Based on Finite Difference Time Domain(FDTD) method, the influence of the parameters such as soil conductance, the depth of the earth electrode buried on the TGR of metal earth electrode has been studied in [8], and in [9] the TGR of a number of shunt-wound

vertical earth electrodes has been analyzed in time domain. These examples mentioned previously are all successful. In this paper a new type of portable horizontal grid earth device has been designed to aim at the current situation that vertical earth device doesn't work in unfavorable geological conditions such as frozen soil, hard clay and so on. With the impulse ground measurement system, the capacity of discharging pulse current of the new earth electrodes has been tested practically. And the influence that different arrangements impact on TGR is analyzed.

II. DESIGN OF EARTH DEVICE AND MEASUREMENT SYSTEM

A. Design of Portable Horizontal Grid Earth Device

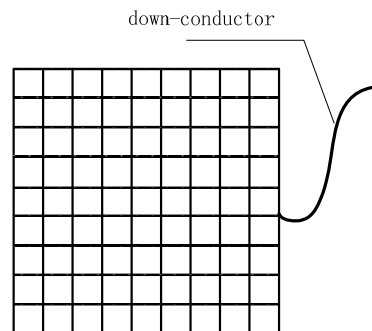

Fig.1 Portable horizontal grid earth device

In current situation, the earth electrodes of mobile equipment are mainly vertical rods such as round bar, angle steel. If the geological conditions are frozen soil, hard clay and so on, the vertical rods wouldn't work or would take a long time to set up.

As Fig.1 shows, the earth electrode's structure is two dimensional grid square, and it's side length is 0.9m. The wefts are composed of multicore copper stranded wires and the warps are thin copper cylinders. All intersections have been welded well to ensure nice contact. The down-conductor is welded at the middle of one side. In addition, there is a cover layer made of soft cloth with good absorption properties. When the earth device works, the cover layer is put on the electrode and sprinkled plasma liquid on.

B. Design of Impulse Ground Measurement System

The measurement system is composed of impulse current source, high voltage sensor, high current sensor, fiber transmission system, data collection system and so on,

The work was supported in part by the Natural Science Foundation of China under grant No.61271106.

as shown in Fig.2. The impulse current source consists of DC high voltage source, high voltage source console, high

voltage pulse capacitance and high voltage discharge switch.

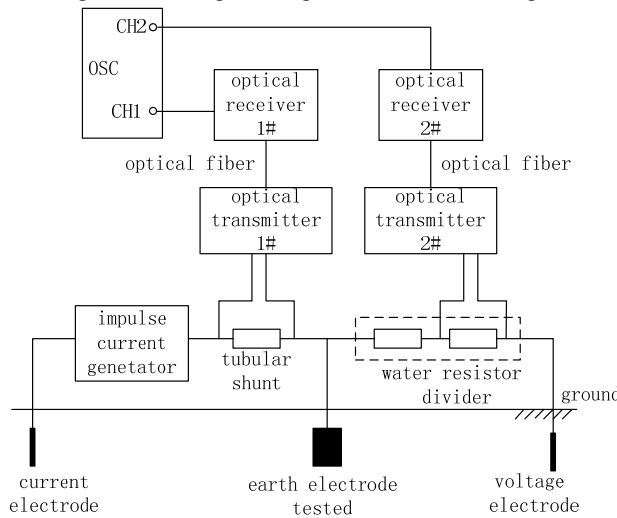

Fig.2 The impulse ground measurement system

When the measurement system works, shut off the high voltage discharge switch firstly to make the DC high voltage source to charge the high voltage impulse capacitance. Turn on the high voltage discharge switch to let high voltage impulse capacitance discharge while the voltage of capacitance reaches the expected value, and then the tested earth electrode is injected the impulse current. So the tested earth electrode and the current electrode make up a discharge circuit where a $2m\Omega$ tubular shunt is series-wound to collect the time domain impulse current wave I_t . And the water divider is series-wound between the tested earth electrode and voltage electrode to collect the

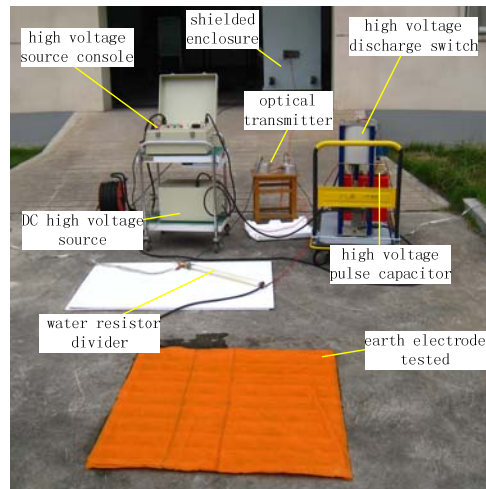

Fig.3 The connection of outdoor devices impulse voltage wave V_t . In the measurement system, two fiber transmission systems are used to connect the exports of voltage divider and current divider with the oscillograph to keep the signal away from the effect of surrounding electromagnetic environment. The instantaneous ratio of V_t and I_t which are both calibrated is the TGR in time domain, that expresses the dynamic response process of earth device to impulse current. The TGR's formula is $Z_t = V_t / I_t$.

III. ANALYSIS OF TESTING DATA

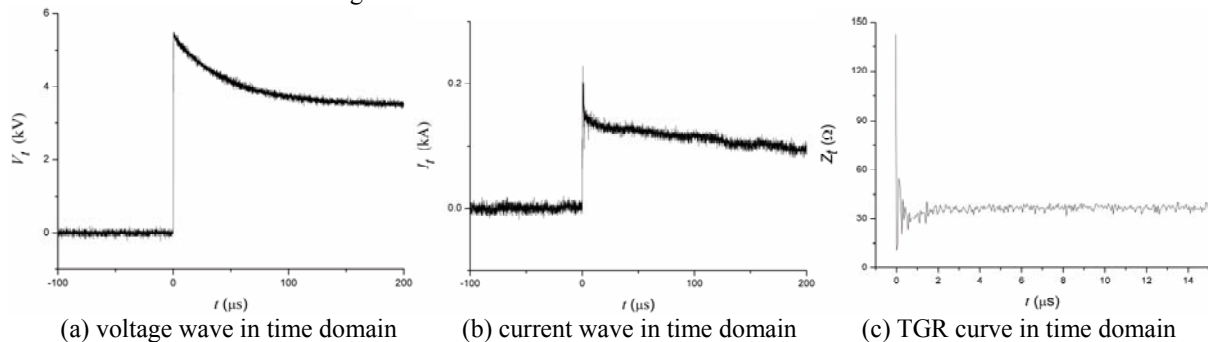

Fig.4 Four electrodes arranged in straight line spaced 0.5m apart

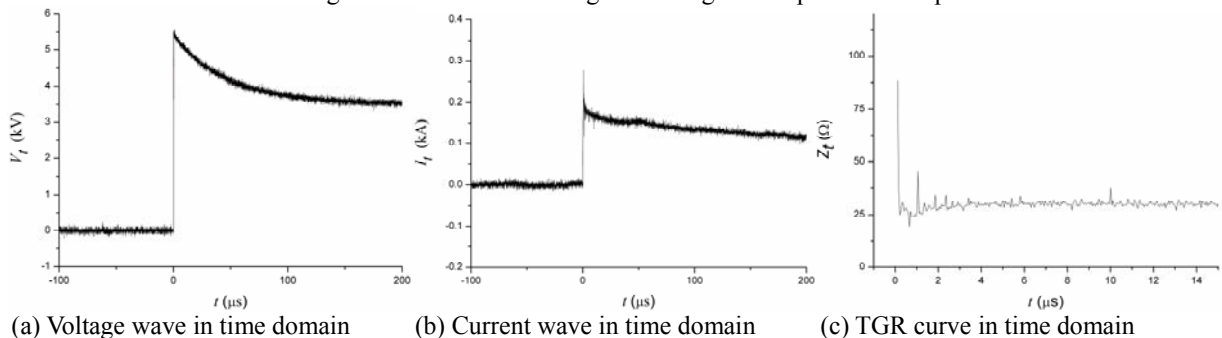
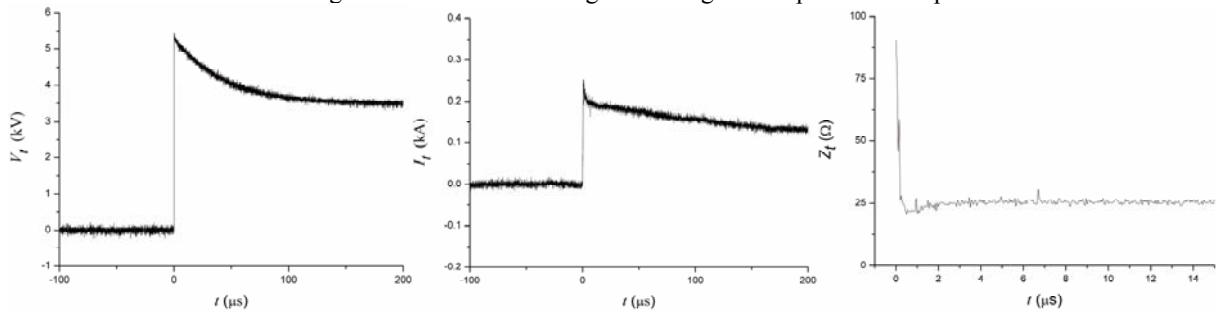
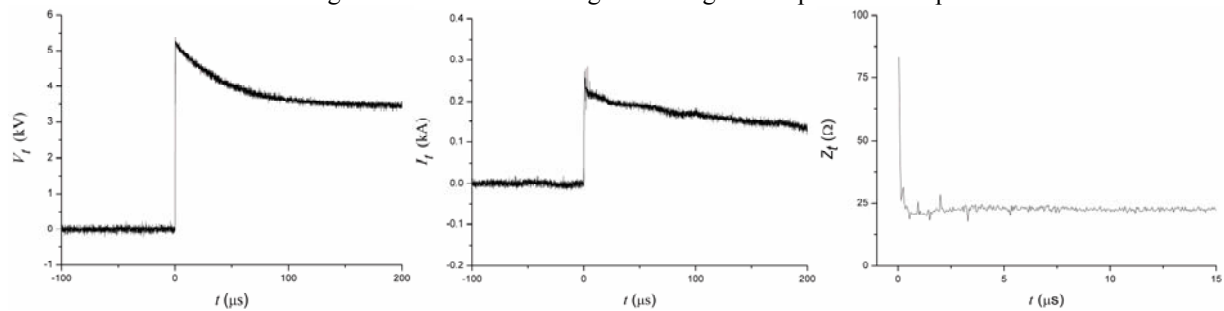

Fig.5 Five electrodes arranged in straight line spaced 0.5m apart



(a) Voltage wave in time domain (b) Current wave in time domain (c) TGR curve in time domain

Fig.6 Four electrodes arranged in straight line spaced 1.0m apart



(a) Voltage wave in time domain (b) Current wave in time domain (c) TGR curve in time domain

Fig.7 Five electrodes arranged in straight line spaced 1.0m apart

Tab.1 Test data list

Arrangement	Power frequency ground resistance(Ω)	TGR (Ω)		
		Maximum	Minimum	Stable value ¹
1	47.9	142.6	20.2	35.78
2	39.5	88.3	19.5	29.66
3	33.1	90.7	20.8	24.45
4	30.5	83.2	18.7	22.74
Remarks	1) The TGR's stable value is the average value of TGR in 5μs ~15μs.			

In the experiment, a number of portable horizontal grid earth electrodes have been taken on five arrangements. The TGRs have been tested separately. The five arrangements are

- 1) Four electrodes arranged in straight line spaced 0.5m apart;
- 2) Five electrodes arranged in straight line spaced 0.5m apart;
- 3) Four electrodes arranged in straight line spaced 1.0m apart;
- 4) Five electrodes arranged in straight line spaced 1.0m apart.

The calibrated voltage waves, current waves and the TGRs curves in time domain of five arrangements are all shown as Fig.4~Fig.8 respectively.

The power frequency ground resistances of five arrangements are tested by tri-electrodes fall-of-potential method separately to compare with the TGR's stable values, as shown in Tab.1.

Compare the data, the results can be obtained:

- 1) At the beginning, every TGR is fluctuant which descends rapidly from the maximum to the minimum. After

2μs, it tends to be stable.

- 2) Compare the TGR's stable value with the corresponding power frequency ground resistances, the former are all lower than the later.

3) With the longitudinal comparison of the TGR's stable values, such results can be gotten. The TGR's stable value of five earth electrodes is lower than four ones in the same arrangement and distance. If the number of earth electrodes is same, the stable value with 1m distance would be lower than that with 0.5m.

Analyze the reasons:

- 1) The TGR's waves in time domain reflect the dynamic response process of earth electrodes discharging impulse current. The process, that the impulse current is discharged to the ground through the earth electrodes, consists of the electrodes' inductance resists the current changing, the capacitor between the electrodes and the ground discharges the current. So the process is fluctuant at the beginning. When the current's rate of change becomes small, the TGR tends to be stable and the value in theory should be close to the power frequency ground resistance.

- 2) he TGR's stable value is lower than power

frequency ground resistance corresponding. The reason should be that the tested earth electrodes lie on the cement grounds horizontally, while the voltage and current rods, which are used in tri-electrodes fall-of-potential method to test the power frequency ground resistance, are set up vertically in the soil near by. This inconsistency result in the error perhaps.

3) In the same arrangement, the more the earth electrodes are, the larger the contact area is and the smaller the TGR's stable value is. With the same number of electrodes, the shorter the distance is, the more remarkable the shielding effect is and the bigger the TGR's stable value is.

IV. CONCLUSIONS

1) With the impulse ground measurement system, the TGR of portable horizontal grid earth electrode has been tested. The experiment's result shows that the capacity of this type of earth electrodes to discharge impulse current is great even on cement grounds.

2) The process of portable horizontal grid earth electrodes discharging impulse current accords with the theory analysis that the TGR reaches the maximum value firstly and then drops to the minimum value rapidly, after waving for about $2\mu\text{s}$, it tends to be stable.

V. REFERENCES

- [1] Zhou Bihua, Chen Bin, Shi Lihua. Electromagnetic Pulse and Engineering Protection [M]. Beijing : National Defence Industrial Press,2003.
- [2] Chen Jiabin. The Earth Technique and Earth-termination System. [M]. China Power Press, Apr. 2009.
- [3] GB 50689-2011 Code for Design of Lightning Protection and Earthing Engineering for Telecommunication Bureaus(Stations) (2012) [S]. Beijing: Chinese Plan Publishing House. Feb. 2012.
- [4] Fan Mian. Development of Tower Grounding Device's Impulse Ground Impedance Measurement System. [D],Xihua University, May 2008.
- [5] Ji Yafei, Yangyu, Zhou Jun. Fast Algorithm for Calculating the Transient Current Distribution of a Lightning Protection System [J],High Voltage Engineering, Oct. 2009.
- [6] Yang Huina. The Determination of the Earth Model and the Simulating Calculation of the Earth Grid's Transient Character [D]. Beijing: Tshinghua University,2003.
- [7] Zhang Bo, Cui Xiang, Zhao Zhibin, etc.. Analysis of the Complex Grounding Grids in Frequency Domain Considering Mutual Inductances. [J]. Proceedings of the CSEE, 2003, 23(4): 77-80, 118.
- [8]. He Hongbing, Zhou Bihua, Yu Tongbin. Analysis of Transient Grounding Resistance Under Pulsed Discharging Current [C]. Proc Asia-Pasific conf on Environmental Electromagnetics, Hangzhou, China, 2003, 554-557.
- [9] Chen Jiaqing, Zhou Bihua, He Hongbing. The Analysis of Transient Grounding Resistance of a Number of Shunt-wound Vertical Grounding Rods in Time Domain [J]. The Lightning Protection and Standardization, 2005.2:11~14.