

## The Design and Simulation of ISO14443a RFID Reader Antenna Matching Circuit based on the MFRC500

Ke Zhang, Hao Wang, Weiwei Zheng, Fuming Zhang  
Beijing Institute of Petrochemical Technology.  
Beijing, China, 102617.  
e-mail: zhangke@bipt.edu.cn, 544601967@qq.com

**Abstract**—Radio frequency identification (RFID) as a new automatic identification technology has relatively obvious technical advantage. In recent years, radio frequency identification (RFID) technology development in the domestic and foreign is very soon. RFID products are many types, such as TI, Motorola, Philips, Microchip and the other world famous manufacturer production RFID products have different features and become the series. RFID has been widely used in industrial automation, commercial automation, transportation control management and many other fields such as car or train traffic monitoring system, the highway to be automatic charge system, item management, production line automation, entrance guard system, financial transactions, storage management, livestock management, vehicle anti-theft, etc. As the costs decrease and standardization using in the truth, RFID technology popularization and the universal application will be irreversible certain tendency. This article, firstly, introduces the background and principle of RFID technology, second, study the RFID reader circuit, then, design the ISO14443A 13.56 MHz passive RFID reader antenna matching circuit based on the MFRC500 by software, finally, attend the validation with the simulation.

**Keywords**—Radio frequency identification; RFID; reader antenna matching circuits; ISO14443A standardization

### I. INTRODUCTION

RFID is the abbreviation of the Radio Frequency Identification technology which achieves non-contact transmission of information through the alternating magnetic field space coupling by using RF signal, and to identify the delivered information. Compared with the automatic identification, such as bar codes, magnetic cards, IC cards, RFID technology has many outstanding advantages. It is suit for high-security terminal. Secure communication and storage, the reader does not pen the physical interface to the end user directly, and it can ensure its own security. And it also can work in a various circumstances of grease, dust, pollution and other harsh environments; no mechanical wearing and Long life. It is the non-contact operation that can complete the identification work without human intervention conveniently. It is because of these advantages, the application of RFID is in full swing in recent years [1].

RFID systems will be different due to different application, however, it is be made up of three basic parts. electronic label (Tag), the card Reader (Reader) and data exchange (Processor) Electronic tags ( or RF card, transponder, etc.), is composed of coupling components and chips, which contains with encryption logic block, serial

EEPROM (electricity can be erased and programmable read only memory (ROM), the microprocessor CPU, and radio frequency transceiver and related circuit. Electronic tag has the function of reading, writing and encrypting communication and it exchanges data through the radio and read/write device .work energy is provided by the radio frequency pulse from the card reader. Card reader, is sometimes called a query editor, legibility, or readout device, which is mainly composed of wireless transceiver module, antenna, control module and interface circuit, etc. Card reader can deliver the command of reading and writing from host to the electronic tag, then encrypt the data which is delivered from host to the electronic tag, and after decryption the data returned by the tags deliver to the host. Data exchange and the management system mainly complete the data storage and management of information, read/write control to the card, etc [2].

RFID system works as following : the information sent by reader ,after encoding, will be loaded in a certain frequency .the carrier signal will be sent out by the antenna, electronic tag reader got into the work area will receive this pulse signal, this signal will be modulated, decoded, decrypted , and then the command request, passwords, permissions, etc. Analyzing. If there is a the reading command, control logic circuit will read the relevant information from memory ,after encrypting , encoding and modulating and sending to the card reader through the antenna inside of the card , card reader will demodulate ,decode and decrypt to the received signal ,and send to the central information system for relating data process; If there is a write command to modify the information, the control logic of internal charge pump working voltage, block provides a wipe EEPROM to rewrite the content, if it is not matched by judging its corresponding password and permission, an error message will be returned [3,4].

### II. THE HIGH INTEGRATED MF RC500-ISO14443A CARD HARDWARE CIRCUIT

Contactless IC card doesn't have mechanical contact to communicate with reading and writing equipment through the wireless way , compared with the IC card .it has the features following: fast operation, high anti-interference, high reliability, suit for a variety of applications, high security, etc [5,6].

Hardware of Contactless IC card read-write device circuit is mainly composed of several parts, diagram of hardware

circuit is shown in fig. 1.

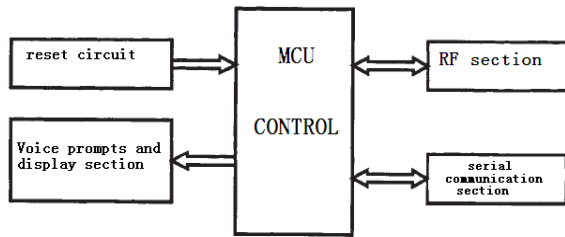

Figure 1. Reading and writing device hardware circuit diagram

### A. MCU Control Part

The part of MCU control is a controlling core of contactless IC card read-write device, which is mainly in charge of initialization in radio frequency base station, to initialize the serial communication part, control communication part to complete the serial data communication with upper machine, receive the upper machine's command, do various operations to contactless IC card through controlling the radio frequency.

### B. The RF Part

Radio frequency parts are key components of the read-write device of contactless IC card, achieving the communication with contactless IC card through this part of the data. Radio frequency part of the main components of radio frequency base station chip, the chosen one is RF base station chip MFRC500 from the NXP company.

MFRC500, which is used in the 13.56 MHz non-contact communications, is the members of highly integrated IC card reader, it uses the advanced concept of modulation and demodulation, fully integrated with all types of passive contactless communication mode and protocol at 13.56 MHz. MFRC500 support all layer protocol in ISO014443A. The transmitter inside does not need increase the active circuit, it is able to drive close antenna to realize communication (communication distance can reach 100 mm). Receiving section provides a strong and effective demodulation and decoding circuit, it is used for processing ISO014443A sign of compatible contactless IC card. Digital signal processing ISO014443A frame and error detection (parity and CRC check). In addition, it supports rapid CRYPTO1 security algorithm in order to verify the MIFARE Classic products (for example, MIFARE Standard, MIFARE Light). Convenient parallel flexibility for the design of read/write device/terminal. MFRC500 chip has 32 pin, as shown in fig.2:

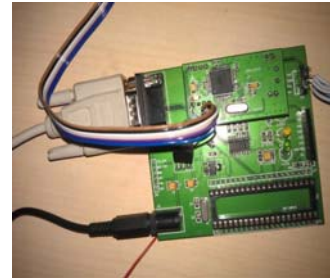
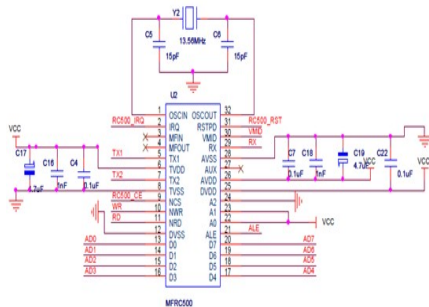

Figure 2. Chip pin diagram and reader Circuit

MFRC500 support directly interface with different microprocessors, Every time after electricity and after the hard reset, MFRC500 also reset the microprocessor parallel connect I: 1 model and test type of the microprocessor interface. after the reset MFRC500

In the design of the contactless IC card read-write device, we adopt the independent read/write strobe and the way of multiplexing address bus. MCU uses interrupt mode, introduce MFRC500 interrupt through INT0 pin source get control by using interrupt information provided by the MFRC500 control [7].

## III. THE DESIGN AND SIMULATION OF READER ANTENNA

### A. Parts of Antenna

According to the MFRC500 manual, antenna part includes four parts: low-pass filter circuit, receiving circuit, the antenna matching circuit and antenna coil [8].

#### 1) Low-pass filter circuit

The work frequency of the reader is produced by a crystal of 13.56 MHz quartz , it can produce the fundamental frequency to drive RC500 and produce antenna's energy carrier at the same time it also produce higher harmonic quartz crystal. From regulations of the EMC, it leads in a low-pass filter circuit among send ports TX1 foot , TX2 foot and ground TVSS feet in radio frequency module in order to suppress the three times in 13.56 MHz, five times and higher harmonic, designing circuit .

#### 2) The receiving circuit

RC500 internal receiving circuit works according to using the concept of returning response signal of non-contact IC card in subcarrier bilateral modulation. According to the chip RC500 manual, produced by RC500 chip internal part VMID which is the input bias of the received signal pin RX. In order to reduce interference, we provide a stable reference voltage, link a capacitance C between the TVSS and VMID, at the same time we connect a resistor between the R as a voltage divider in the RX and VMID pin.

#### 3) The antenna matching circuit

Reader working distance is determined by three factors: size of the reader antenna, quality factor Q of the antenna matching circuit and reader surrounding environmental. Therefore, we need to fully consider the factor of three parts when designing the antenna. This part is the key to the whole antenna design, it will be detailed below.

## B. Steps of Antenna Designing

### 1) Basic designing rule

Designing in this paper, based on RC500 contactless IC card read-write device, the antenna part of its system configuration mode will be shown in fig. 3:

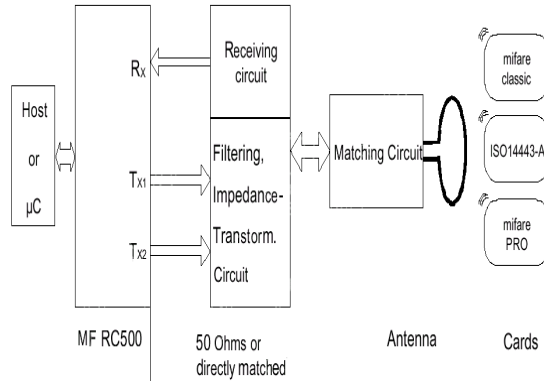

Figure 3. Matching antenna system configuration diagram

Antenna need to satisfy the three basic conditions:

- the load impedance matching circuit 700
- resonant frequency of 13.56 MHz
- the quality factor Q is about 35 (Mifare system) working distance of MIFARE system is determined by the following several factors:
  - the size of reader antenna
  - matching circuit quality of the given antenna
  - impact of environment

### 2) The design of the antenna coil

Card reader antenna coil can be expressed on the left side of the equivalent circuit in fig. 6. We suggest design directly antenna which would have a center tap of linking ground. The center tap is used to improve the EMC performance of the antenna coil. Coil can be expressed by inductance L and  $L_b$ , the resistors  $R_a$  and  $R_b$  represents the resistance loss, Parallel  $C_a$  and  $C_b$  represent the capacitive losses.

In the process, the complete mode can be taken the place of the model as the fig. 4. the whole antenna coil between Tx11 and Tx12 can be represented by  $L_{ant}$ , all the resistance loss can be represented with  $R_{ant}$ . Coil capacitance the  $C_{ant}$  represents the capacitance between the coil and the connector loss.

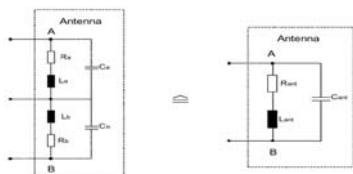

Figure 4. Circuit diagram of directly match the antenna coil

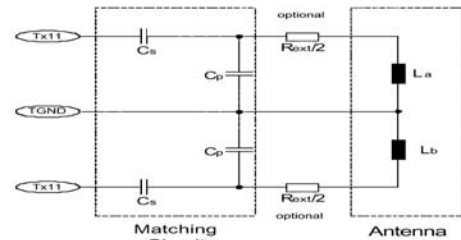

Figure 5. The antenna matching circuit

### 3) Design of the antenna matching circuit

Because the impedance of the antenna is not high, we need a matching circuit in order to link the part of radio frequency circuit. Whether The antenna matching circuit design is reasonable will directly affect the antenna can work normally or not. Antenna matching circuit is shown in fig. 5.

### 4) Tuning of the antenna

To obtain the optimal performance, the antenna must be tuned properly. Antenna tuning needs to be conducted on a complete terminal, this includes all parts of the terminal should be connected to the power supply properly, and adjust the PCB of the antenna and reader to their final position.

## C. The Influence Of Environment To The Antenna

### 1) Metal antenna environment

Any changing magnetic field will induct voltage metal components on the induction voltage near the read/write device antenna, the induced voltage can produce eddy current in the metal surface, eddy current will result in disorder of antenna and abate the magnetic field. The results of these effects are to reduce the working distance and transmission errors may be produced. So the distance of antenna and massive metal components is the working distance at least, if we want to avoid negative effects we need to use iron to block

### 2) The influence of the plurality of antennas

Antenna is the oscillation circuit of having a high quality factor and tuned to work frequency. According to the law of reciprocity, According to reciprocity, good transmission antenna is also good the reception one and vice versa .That is to say: antenna is placed very close to the used card reader antenna and tuned to the same frequency, it will consume the energy of the magnetic field. At this time it produce antenna disturbance and reduce the working distance. If a MIFARE system has two effective antenna, and they are placed closely, communications of the card would be disturbed.

### 3) The temperature effects

The temperature drift of Antenna itself and the matching circuit electronic parameters may lead to imbalance, the result would reduce transmitting power of antennas, reduce the working distance.

## D. The Simulation Of Antenna

### 1) Introduction to simulation software

CST MICROWAVE STUDIO (the shortened form is CST MWS, the Chinese name is "CST MICROWAVE STUDIO")

is one of the CST STUDIO suite software produced by CST company, is the flagship product of CST software, widely used in the high frequency passive device simulation, it can be Lightning from EMP, strong electromagnetic pulse, electrostatic discharge, ESD, EMC/EMI, signal integrity, power integrity/SI/PI, TDR and all kinds of antenna RCS simulation. In combination with other studios, for instance importing CST PCB Studio and CST cable studio space three-dimensional frequency domain amplitude and phase current distribution ,it can complete system-level emc simulation; it can simulate collaboratively with unique pure transient field-circuit synchronous in CST design studio.

## 2) The simulation results

The simulation results show that the design and simulation methods which are described as Fig. 6 are correct, and the antenna circuit and practical design diagram have been gained as Fig. 7 and 8.

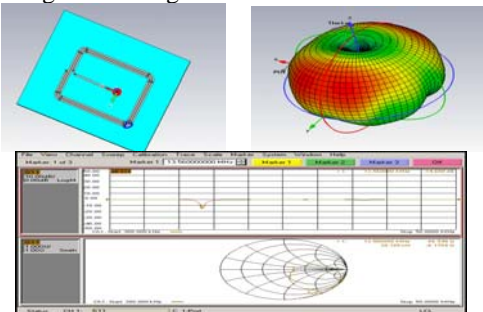

Figure 6. (a) Antenna simulation diagram;(b)Direction of antenna simulation diagram ;(c) Antenna of return loss and Smith chart

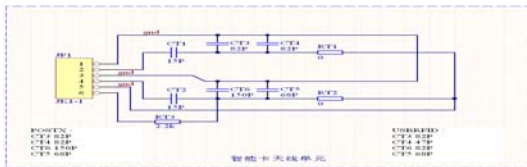

Figure 7. Antenna circuit diagram

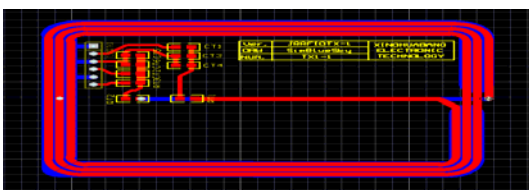

Figure 8. Antenna design

## IV. CONCLUSION

This article summarize the background and working principle of RFID technology, and research the contactless IC card read and write machine, and chips, according to the standard of ISO/IEC14443, it mainly complete hardware design of reading and writing device including hardware selection, hardware circuit principle diagram, test and so on; It complete antenna design of the reading and writing, including the size of antenna coil , the design of the matching circuit and the antenna's debugging, work etc. After debugging and experiment of the whole system, the designed

read-write device is capable of doing researching, preventing collision, certificating, reading and writing data and other operations to Mifare1 CARDS.

Then, using software programming method to design the antenna matching circuits based on the MFRC500 ISO14443A standard under 13.56 MHz. The simulation results show that the design requirements are consistent with the theory. This provide safe, effective and reliable experiment platform for development of the RFID system.

## REFERENCES

- [1] Wang Aiyong. Smart card technology [M]. Beijing: Tsinghua university study press, 2000.45.155.
- [2] You Zhanqing, Li Sujian. Radio frequency identification technology (RFID) theory and application [M]. Beijing: electronic industry press, 2004.
- [3] Ma Xiuli. MIFARE contactless IC card technology characteristics and application of shallow xi Yin. The gold card project, 2005, (3) : 35.36.
- [4] He Lifang, Fan Junbo. Non-contact IC card technology and its development and application. Communications and information technology, 2003, (7) : 23-24.The People's Republic of China ministry of science and technology, 2006.2 3
- [5] fifteen ministries and commissions such as science and technology department of the People's Republic of China. China radio frequency identification (RFID) technology policy white paper [R]. Beijing: The People's Republic of China ministry of science and technology, 2006.2 3
- [6] ISO/IEC 14443, 1. Identificationcards - Contactless integratedcircuit (s) CARDS, Proximity card - Part 1: Physicalcharacteristics [s].
- [7] Klaus Finkenzeller. RFID faced Rachel translated. Second Edition. 2003.
- [8] Zhou Zhinan, wang zhiping, Luo Yi. Based on the four MFRC500 module of radio frequency identification system front-end circuit design. Journal of shaanxi normal university (natural science edition), 2004, 23 (4) : 56.61.